

DEPARTMENT OF THE ARMY TECHNICAL MANUAL

---

ORGANIZATIONAL, DS, GS, AND DEPOT  
MAINTENANCE MANUAL

PUMP, CENTRIFUGAL, GASOLINE DRIVEN,

SKID MOUNTED, 6-INCH, 1120 GPM,

SELF-PRIMING (CARVER MODEL K906EWA:

FSN 4320-968-6264

This copy is a reprint which includes current  
pages from Changes 2 through 4.

---

HEADQUARTERS, DEPARTMENT OF THE ARMY  
FEBRUARY 1966

Changes in Force: C 2, C 3, and C 4

CHANGE

NO. 4

HEADQUARTERS  
DEPARTMENTS OF THE ARMY  
WASHINGTON, D.C., 10 October 1990

Operator, Organizational, Direct Support  
General Support, and Depot Maintenance Manual

PUMP, CENTRIFUGAL; GASOLINE DRIVEN, SKID MOUNTED, 6-INCH,  
1120 GPM, SELF-PRIMING (CARVER MODEL K906EWA)  
FSN 4310-968-6264

Approved for public release; distribution is unlimited

TM 5-4320-233-15, 7 February 1966, is changed as follows:

Page 16, paragraph 29, add the following paragraph:

e. Batteries. Increase battery PMCS frequency. Use distilled water or a good grade of drinking water (excluding mineral water) to bring electrolyte to proper level.

Page 34, paragraph 65 add the following note:

**NOTE**

**The 6TN and 6TL batteries can be mixed or matched. However, maintenance-free batteries cannot be mixed or matched with military batteries.**

The 6TN and or the 6TL batteries will perform properly in hot weather as long as electrolyte levels are carefully monitored. If the electrolyte expands and causes the level to rise, some fluid must be removed. If the level becomes too low due to evaporation, distilled water may be used to obtain the proper level. A good grade of drinking water (excluding mineral waters) may be used if distilled water is not available.

Electrolyte (NSNs 6810-0-249-9354 and 6810 0-843-1640) has a specific gravity of 1.280 and should be used in these batteries. Do NOT adjust the electrolyte in wet batteries to a lower specific gravity.

By Order of the Secretary of the Army:

**CARL E. VUONO**  
*General, United States Army*  
*Chief of Staff*

Official:

**THOMAS F. SIKORA**  
*Brigadier General, United States Army*  
*The Adjutant General*

DISTRIBUTION:

To be distributed in accordance with DA Form 12-25E, (qty rqr block no. 1390).

**1/(2 Blank)**

Changes in force: C 2 and C 3

Change }  
No. 3 }

HEADQUARTERS  
DEPARTMENT OF THE ARMY  
Washington, DC, 29 April 1974

Operator, Organizational, Direct Support  
General Support, and Depot Maintenance Manual  
PUMP, CENTRIFUGAL; GASOLINE DRIVEN, SKID MOUNTED, 6-INCH,  
1120 GPM, SELF PRIMING (CARVER MODEL K906EWA)  
FSN 4310-968-6264

TM 5-4320-233-15, 7 February 1966, is changed as follows:

*Inside Front Cover.* Add the following warnings to the list of safety precautions:

**WARNING**

**Operation of this equipment presents a noise hazard to personnel in the area. The noise level exceeds the allowable limits for unprotected personnel. Wear ear muffs or ear plugs which were fitted by a trained professional.**

**WARNING**

**Dry cleaning solvent, P-D-680, used to clean parts is potentially dangerous to personnel and property. Do not use near open flame or excessive heat. Flash point of solvent is 100°F. 138°F.**

*Page 3.* Paragraph Id is superseded as follows:

d. You can help to improve this manual by calling attention to errors and by recommending improvements. Your letter or DA Form 2028 (Recommended Changes to DA Publications and Blank Forms) should be mailed direct to: Commander, US Army Troop Support Command, ATTN: AMSTS-MPP, 4300 Goodfellow Blvd., St. Louis, MO 63120. A reply will be furnished direct to you.

*Page 13.* Immediately after Section III title, add the following warning:

**WARNING**

**Operation of this equipment presents a noise hazard to personnel in the area. The noise level exceeds the allowable limits for unprotected personnel. Wear ear muffs or ear plugs which were fitted by a trained professional.**

*Page 17.* Immediately after Chapter 3 title, add the following warning.

**WARNING**

**Dry cleaning solvent, P-D-680, used to clean parts is potentially dangerous to personnel and property. Do not use near open flame or excessive heat. Flash point of solvent is 100°F. 138°F.**

*Page 90,* paragraph 5. Appendix I, References, add the following: "TB MED 251, Noise and Conservation of Hearing".

By Order of the Secretary of the Army:

Official:

VERNE L. BOWERS  
*Major General, United States Army*  
*The Adjutant General*

CREIGHTON W. ABRAMS  
*General, United States Army*  
*Chief of Staff*

Distribution:

To be distributed in accordance with DA Form 12-25A (qty rqr block No. 154), Organizational maintenance requirements for Petroleum Distribution.

Changes In force: C2

Change  
No. 2

HEADQUARTERS  
DEPARTMENT OF THE ARMY  
Washington, D.C., 19 July 1972

Operator, Organizational, Direct Support  
General Support, and Depot Maintenance Manual  
PUMP, CENTRIFUGAL; GASOLINE DRIVEN, SKID MOUNTED, 6-INCH,  
1120 GPM, SELF PRIMING (CARVER MODEL K906EWA)  
FSN 4310-968-6264

TM 5-4320-233-15, 7 February 1966, is changed as follows:

Cover and Title page is changed as shown above.

Page 3. Paragraph Id is superseded as follows:

d. Report of errors, omissions and recommendations for improving this manual by the individual user is encouraged. Reports should

be submitted on DA Form 2028 (Recommended Changes to Publications) and forwarded direct to Commanding General, U.S. Army Mobility Equipment Command, ATTN: AMSME-MPP, 4300 Goodfellow Boulevard, St. Louis, Mo. 63120.

Page 9. Paragraph 9h is added as follows:

h. A list of maintenance and operating supplies required for initial operation of the pump are contained in table 0.

**APPENDIX II**  
**BASIC ISSUE ITEMS LIST AND ITEMS**  
**TROOP INSTALLED OR AUTHORIZED**

**Section I. INTRODUCTION**

**B-1. Scope**

This appendix lists items required by the operator for operation of the pump.

**B-2. General**

This list is divided into the following sections:

a. Basic Issue Items List-Section II. Not applicable.

b. Items Troop Installed or Authorized List Section III. A list of items in alphabetical sequence, which at the discretion of the unit commander may accompany the pump. These items are NOT subject to turn-in with the pump when evacuated.

**B-3. Explanation of Columns**

The following provides an explanation of columns in the tabular list of Basic Issue Items List, Section II, and Items Troop Installed or Authorized, Section III.

a. Source, Maintenance, and Recoverability Code(s) (SMR):

(1) Source Code, Indicates the source for the listed item. Source codes are:

<i>Code</i>	<i>Explanation</i>
P	Repair parts, special tools and test equipment supplied from. GSA/DSA or Army Supply System and authorized for use at indicated maintenance levels.

*Code*                                *Explanation*  
P2 .....Repair Parts, Special Tools and Test Equipment which are procured and stocked for insurance purposes because the combat or military essentially of the end item dictates that a minimum quantity be available in the supply system.

(2) Maintenance code, indicates the lowest level of maintenance authorized to install the listed item. The maintenance level code is:

*Code*                                *Explanation*  
C                                       Crew/Operator

(3) Recoverability code, indicates whether unserviceable items should be returned for recovery or salvage. Items not coded are non-recoverable. Recoverability codes are:

*Code*                                *Explanation*  
R .....Applied to repair parts (assemblies and 6components), special tools and test equipment which are considered economically repairable at direct and general support maintenance levels.  
S .....Repair Parts, Special Tools, Test Equipment and assemblies which are .economically repairable at DSU and GSU activities and which normally are furnished by supply on an exchange basis.

b. Federal Stock Number. This column indicates the Federal stock number assigned to the item and will be used for requisitioning purposes.

c. Description. This column indicates the Federal item name and any additional description of the item required.

d. Unit of Measure (U/M). A 2 character alphabetic abbreviation indicating the amount or quantity of the item upon which the allowance are based, e.g., ft, ea, pr, etc.

e. Quantity Furnished with Equipment (BIIL Only). This column indicates the quantity of an item furnished with the equipment.

f. Quantity Authorized (Items Troop Installed or Authorized Only). This column indicates the quantity of the item authorized to be used with the equipment.

g. Illustration (BIIL Only). This column is divided as follows:

- (1) *Figure number*. Indicates the figure number of the illustration in which the item is shown.
- (2) *Item number*. Indicates the callout number used to reference the item in the illustration.

**Section III. ITEMS TROOP INSTALLED OR AUTHORIZED LIST**

(1) SMR code	(2) Federal stock number	(3) Description  Ref. No. & Mfr code                                Usable on code	(4) Unit of meas	(5) Qty auth
PC	7520-559-9618	CASE. MAINTENANCE AND OPERATION BIANUALS	EA	I

By Order of the Secretary of the Army:

BRUCE PALMER, JR.  
*General, U.S. Army*  
*Acting Chief of Staff*

Official:

VERNE L. BOWERS,  
*Major General, United States Army,*  
*The Adjutant General*

Distribution:

To be distributed in accordance with DA Form 12-25A (qty rqr block No. 154) organizational maintenance requirements for Petroleum Distribution.

*This manual contains copyrighted material.*

TECHNICAL MANUAL }  
 No. 5-4320-233-15

HEADQUARTERS  
 DEPARTMENT OF THE ARMY  
 WASHINGTON, D.C., 7 February 1966

**ORGANIZATIONAL, DS, GS, AND DEPOT**

**MAINTENANCE MANUAL**

**PUMP, CENTRIFUGAL, GASOLINE DRIVEN, SKID MOUNTED, 6-INCH,**

**1120 GPM, SELF-PRIMING (CARVER MODEL K906EWA)**

**FSN 4320-968-6264**

		Paragraph	Page
CHAPTER	1. INTRODUCTION		
Section	I. General.....	1-2	1
	II. Description and data .....	3-5.1	4
CHAPTER	2. INSTALLATION AND OPERATION INSTRUCTIONS		
Section	I. Service upon receipt of equipment.....	6-11	8
	II. Controls and instruments .....	12-24.2	11
	III. Operation under usual conditions .....	25-27	13
	IV. Operation under unusual conditions .....	28-32	15
CHAPTER	3. OPERATOR AND ORGANIZATIONAL MAINTENANCE .....		
	I. Special tools and lubricants.....	33-34	17
	II. Preventive maintenance services .....	35-37	20
	III. Troubleshooting .....	38-51.1	25
	IV. Radio interference suppression .....	52-56	26
	V. Fuel system .....	57-63	27
	VI. Engine electrical system .....	64-71	34
	VII. Coolant system .....	72-76	40
	VIII. Lubrication system .....	77-81	43
	IX. Engine .....	82-86	46
	X. Controls and instrument .....	87-97	48
	XI. Hood and side panels.....	98-99	50
	XII. Pressure lines .....	99.1-99.2	53
CHAPTER	4. DIRECT AND GENERAL SUPPORT AND DEPOT MAINTENANCE INSTRUCTIONS		
Section	I. Engine repair and replacement standards .....		54
	II. Removal of major items.....	100-104	55
	III. Engine speed governor .....	105-106	60
	IV. Engine electrical system .....	107-110	61
	V. Coolant system .....	111-113	69
	VI. Engine overhaul .....	114-122	72
	VII. Pump repair .....	123-127	85
	VIII. Skid base and related parts.....	128-129	88
APPENDIX	I. REFERENCES .....		90
	II. BASIC ISSUE ITEMS LIST AND MAINTENANCE AND OPERATING SUPPLIES		92
	III. MAINTENANCE ALLOCATION CHART .....		96
INDEX.	.....		99



# CHAPTER 1 INTRODUCTION

## Section I.- GENERAL

### 1. Scope

a. These instructions are published for the use of the personnel to whom the centrifugal pump is issued. Chapters 1 through 3 provide information On the operation, preventive maintenance services, and organizational maintenance of the equipment, accessories, components, and attachments. Chapter 4 provides information for direct and general support and depot maintenance. Also included are descriptions of main units and their functions in relationship to other components.

b. Appendix I contains a list of publications applicable to this manual. Appendix II contains the list of basic issue items authorized the operator of

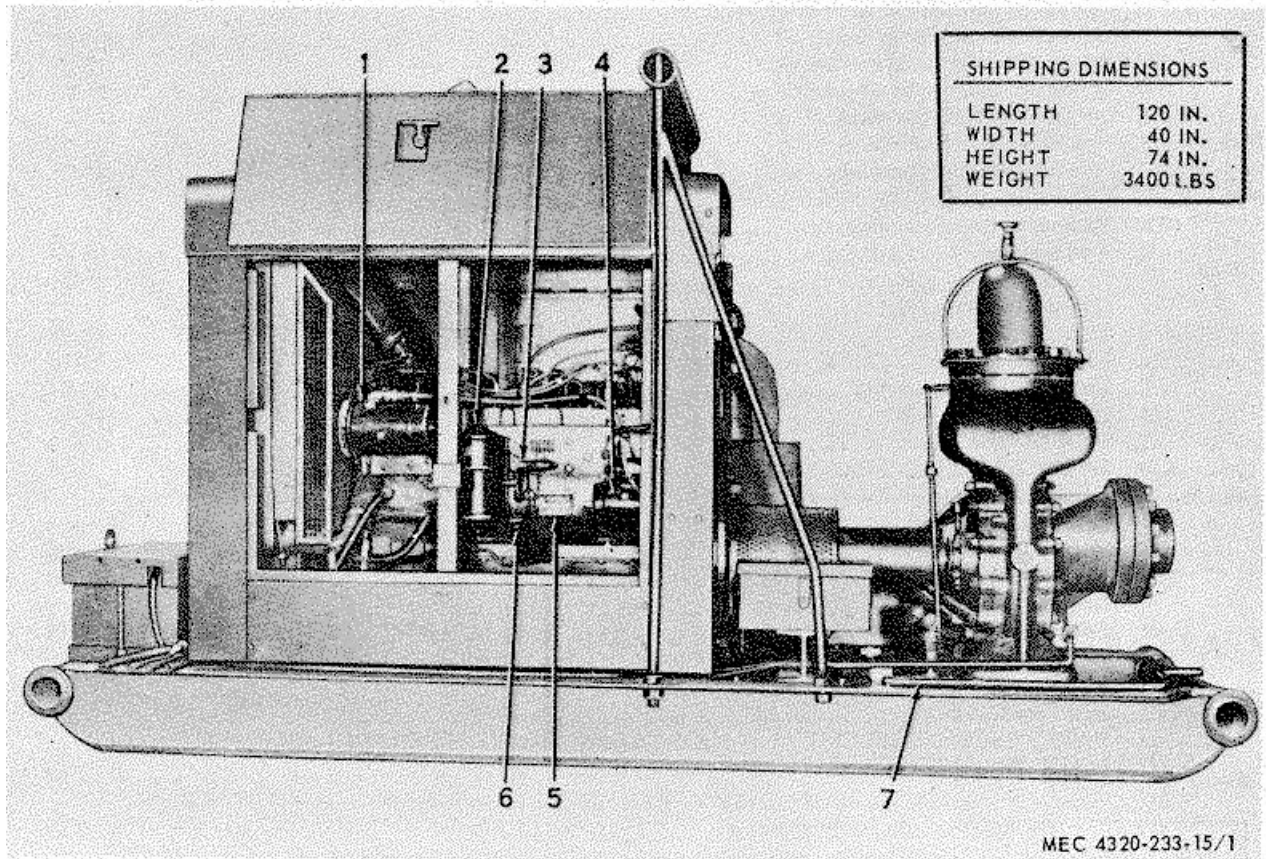

- 1. Generator
- 2. Oil filter
- 3. Level rod
- 4. Starting motor
- 5. Engine nameplate
- 6. Oil filter cap
- 7. Handcrank

**Figure 1. Centrifugal pump, left side view, with panels open.**

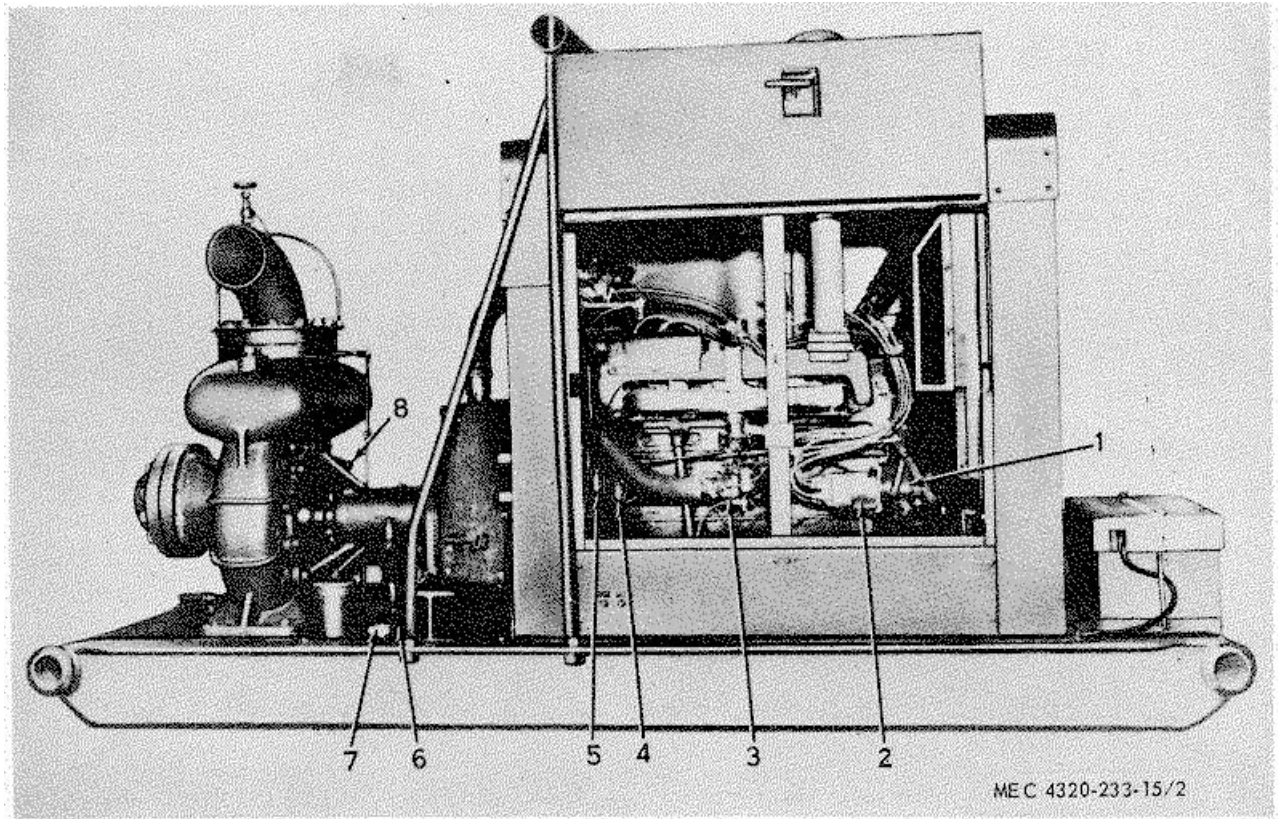

- |               |                |                            |
|---------------|----------------|----------------------------|
| 1. Governor   | 4. Fuel pump   | 7. Liquid level gage       |
| 2. Magneto    | 5. Fuel filter | 8. Pump packing grease cup |
| 3. Carburetor | 6. Fuel tank   |                            |

**Figure 2. Centrifugal pumps right side New, with panels open.**

this equipment and the list of maintenance and operating supplies required for initial operation. Appendix III contains the maintenance allocation chart.

c. Numbers in parentheses on illustrations indicate quantity. Numbers preceding nomenclature callouts on illustrations indicate the preferred maintenance sequence.

d. The direct reporting by the individual user of errors, omissions, and recommendations for improving this manual is authorized and encouraged. DA Form 2028 (Recommended Changes to DA Publications) will be used for reporting these improvements. This form will be completed using pencil, pen, or typewriter and forwarded direct to Commanding General, U.S. Army Mobility Equipment Center, ATTN: SMOME-MPD, 4300 Goodfellow Blvd., St. Louis, Mo. 63120

e. Report all equipment improvement recommendations as prescribed by TM 38-750.

## 2. Record and Report Forms

a. DA Form 2258 (Depreservation Guide for Vehicles and Equipment).

b. For other record and report forms applicable to operator, crew, and organizational maintenance, refer to TM 38-750.

**Note**  
**Applicable forms, excluding standard Form 46 which is carried by the operator, will be kept in a canvas bag mounted on the equipment.**

## Section II. DESCRIPTION AND DATA

### 3. Description

a. The Model K906EWA pump (figs. 1 through 4) is a 6-inch, self-priming, centrifugal, petroleum pump, close-coupled to a Continental Model MS330-6065P gasoline engine. A check valve is mounted internally on the suction side of the pump. The pumping unit is mounted on skids.

b. The pumping unit is equipped with a 24-volt electrical system for starting the engine. A handcrank is also provided for manual starting.

### 4. Identification

a. *Engine Nameplate.* The engine nameplate is, mounted on the side of the engine block near the oil level indicator rod.

b. *The U.S. Army Nameplate.* The Corps of Engineers nameplate is mounted on upper left corner of the pump side of the engine housing and contains normal Corps of Engineers information including stock number, manufacturer, shipping dimensions and weights, capacity etc.

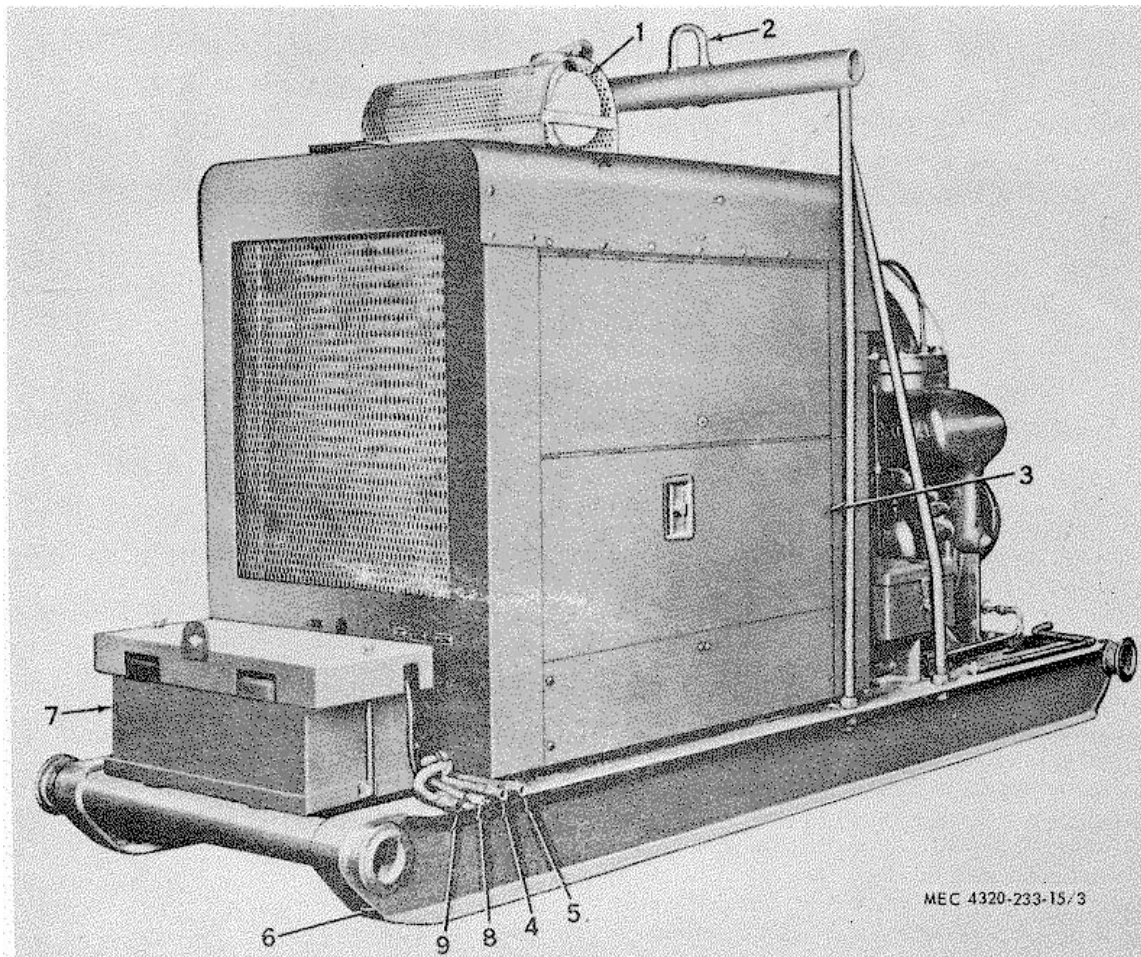

- |                 |                     |                              |
|-----------------|---------------------|------------------------------|
| 1. Muffler      | 4. Coolant drain    | 7. Battery box               |
| 2. Lifting bail | 5. Engine oil drain | 8. Radiator oil cooler drain |
| 3. Engine unit  | 6. Skid             | 9. Block coolant drain       |

Figure 3. Centrifugal pump, left rear view.

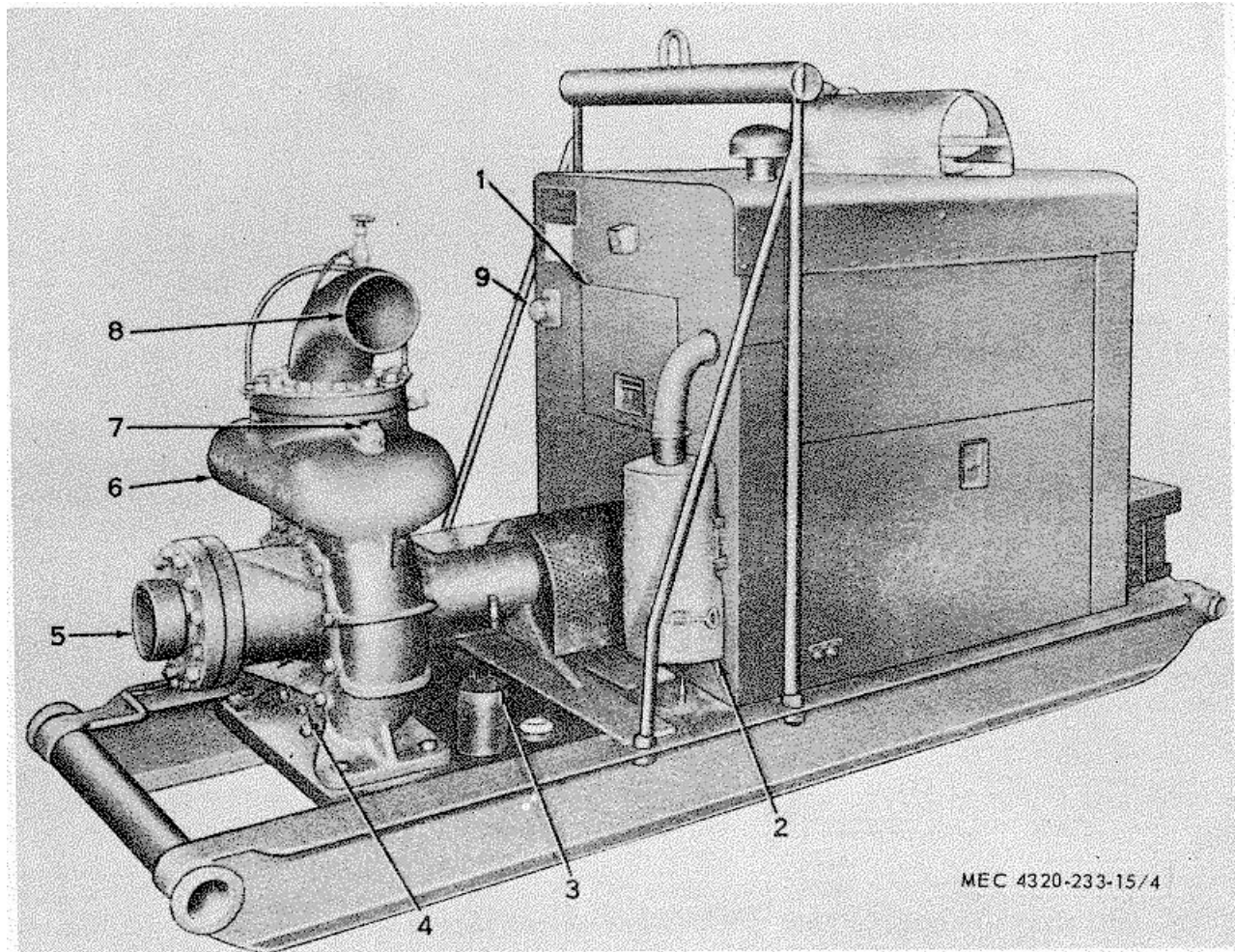

- |                           |                     |                                |
|---------------------------|---------------------|--------------------------------|
| 1. Instrument panel cover | 5. Intake port      | 8. Output port                 |
| 2. Air cleaner            | 6. Centrifugal pump | 9. Battery charging receptacle |
| 3. Fuel tank finer cap    | 7. Primer port plug |                                |
| 4. Pump drain plug        |                     |                                |

**Figure 4. Centrifugal pump, right front view.**

**5. Tabulated Data**

*a. Pump.*

Manufacturer.....Carver Pump Co.  
 Model.....K906EWA  
 Type.....Self-priming centrifugal  
 Number of stages.....One  
 Method of priming.....Integral self-priming  
 Rated capacity at 100 ft (foot).....1,120 gpm  
 (gallons per minute)

*b. Lingo.*

Make.....Continental Motors Corp.  
 Model.....MS330-6065P  
 Type.....Water-cooled  
 Number of cylinders.....Six  
 RPM (revolutions per minute) 1,800  
 Fuel.....Gasoline  
 Firing order  
 1-5-3-6-2 -

Rated horsepower c 60.4 net continuous

Bore.....4.000  
 Stroke.....4-375  
 Displacement.....330 cu.  
 .....in.  
 .....(cubic inches)

*c. Accessory Items.*

Oil filter, F31-PL.....Fram  
 Air cleaner, XAX00-0376.....Donaldson  
 Carburetor, 63AW11.....Zenith  
 Batteries.....Two, 12-volt, negative ground  
 Fuel filter, 5650470.....AC  
 Governor, 56585-A.....Novi  
 Fuel pump, 5594440.....AC  
 Magneto, 625R.H.....Slick  
 Generator, GHS-6002-TS.....Prestolite  
 Starting motor, 1108266.....Delco-Remy  
 Voltage regulator, VBU-40Q2UT.....Prestolite

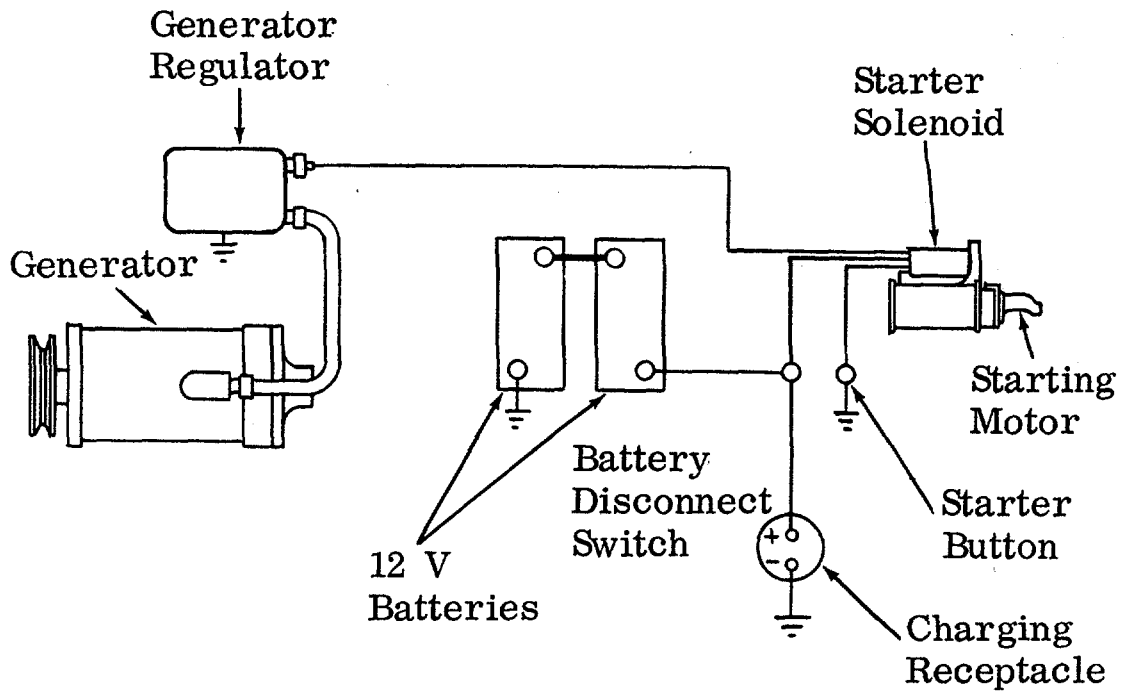

STARTING MOTOR,  
GENERATOR AND BATTERY CIRCUIT

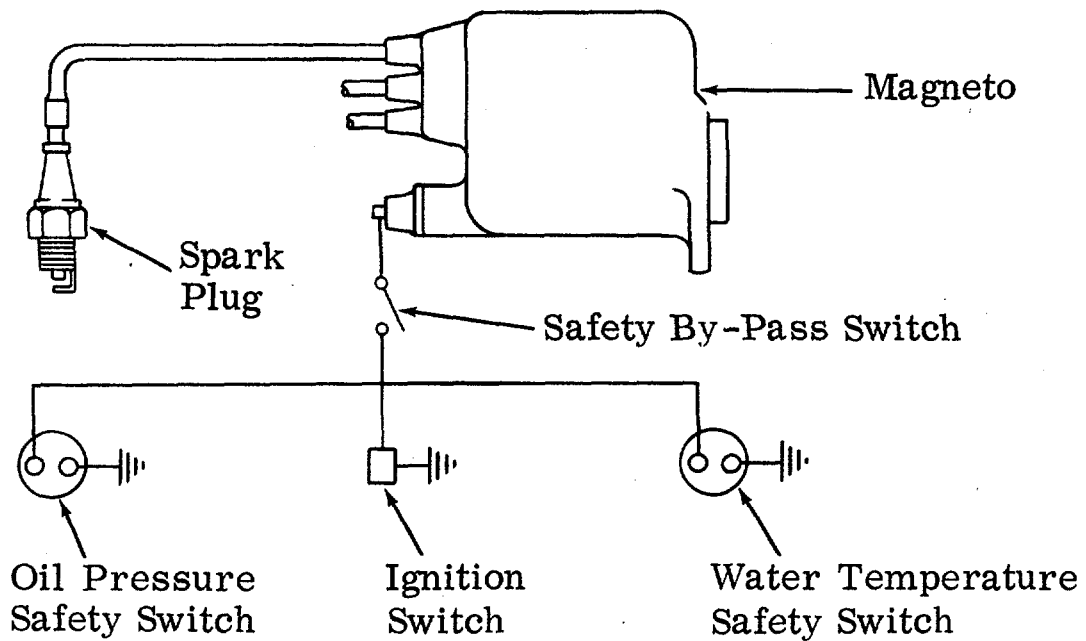

IGNITION CIRCUIT

MEC 4320-233-15/5

Figure 5. Wiring Diagram

*d. Capacities.*

Crankcase with filter.....	8 quarts
Crankcase without filter.....	7 quarts
Cooling system .....	33 quarts
Fuel tank .....	13 gallons

*e Adjustment Data.*

Valve clearance:

Intake .....	0.017 in. (inch)
Exhaust .....	0.020 in.
Spark plug gap.....	0.025 in.
Magneto breaker points.....	0.008 to 0.012 in.

*f Torque Data.*

Cylinder head nuts...	70 to 75 ft-lb (foot-pounds)
Oil pan and filler block screws.....	12 to 16 ft-lb
Connecting rod capnuts.....	70 to 75 ft-lb
Flywheel nuts.....	85 to 95 ft-lb
Main bearing cap screws.....	85 to 95 ft-lb
Camshaft gear nut.....	85 to 90 ft-lb

*g Wiring Diagram.*

Pump wiring diagram.....	5
--------------------------	---

*h Shipping Dimension.*

Length .....	120 in.
Width .....	40 in.
Height .....	74 in.
Weight .....	3,400 lb (pounds)

*i Base Plan.*

Base pump dimensions.....figure 6

*j Maintenance and Operating Supplies (8-Hr Period.)* Maintenance and operating supplies are listed in appendix II.

*k Performance Data.*

Speed .....	1,800 rpm
Capacity vs. Head.....	245 gpm at 205 ft head
	729 gpm at 180 ft head
	1,120 gpm at 100 ft head

**5.1 Differences in Models**

This manual covers only centrifugal pump model K906EWA. No known unit differences exist for the model covered by this manual.

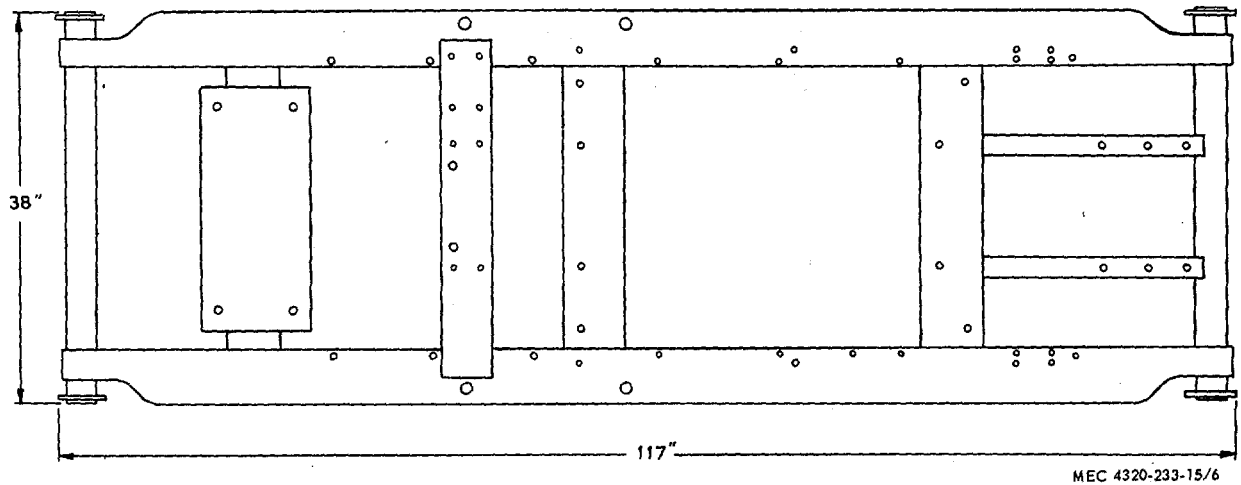

**Figure 6. Base plan.**

## CHAPTER 2

### INSTALLATION AND OPERATION INSTRUCTIONS

#### Section I. SERVICE UPON RECEIPT OF EQUIPMENT

##### 6. Unloading Equipment

- a. Remove all tiedown straps and blocks that secure the pumping unit to the bed of the carrier.
- b. Remove the pumping unit from the bed of the carrier with a crane. Attach the crane hook to the lifting bail (fig. 7).

##### **Warning**

**When lifting the pumping unit, be sure the lifting device has a capacity of at least 3,400 pounds. Do not allow the pumping unit to swing while suspended. Failure to observe this warning may result in damage to the unit and severe injury to personnel.**

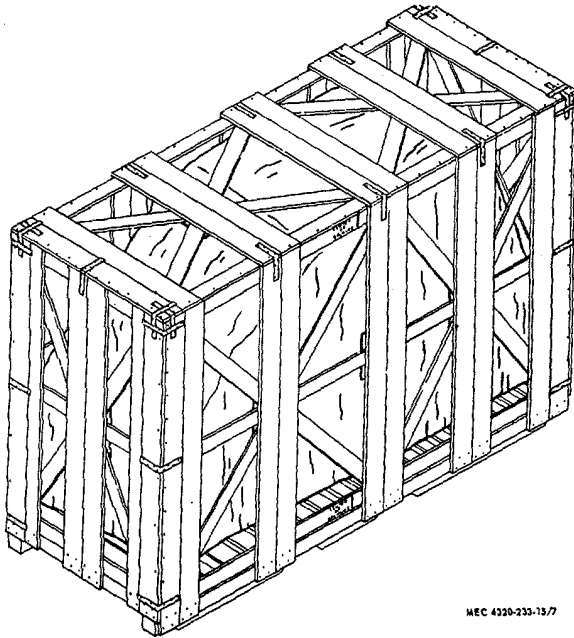

**Figure 7. Pump readied for shipment.**

##### 7. Unpacking Equipment

Position the pumping unit as near as possible to the source of supply. Remove the protective packing

material from areas shown in figure 8. When a DA Form 2258 (Depreservation Guide) is furnished, accomplish depreservation as outlined in this guide.

##### 8. Inspection of Equipment

- a. Inspect the equipment to be sure that all parts are received intact.
- b. Inspect the pumping unit for damage and for secure mounting of parts, paying particular attention to areas shown in figure 9.
- c. Follow instructions on depreservation tag attached to equipment.
- d. Check that engine holddown bolts and foot bolts are firmly set.

##### 9. Servicing Equipment (fig. 10)

- a. Open the fuel tank shutoff valve installed in the fuel piping near the fuel pump (4, fig. 2).
- b. Examine the oil drain plug and coolant drain plugs 4, 5, 8, and 9, fig. 3) to make certain that they are tightly closed.
- c. Perform all the lubrication recommendations in lubrication section (para 34) except that for the first 50 hours of operation use SAE 10W-30 in the engine crankcase. After 50 hours operation, drain and fill in accordance with the lubrication order (fig. 14).
- d. Fill the radiator with clean water. During freezing weather, use a sufficient amount of antifreeze to protect the system for the lowest temperature anticipated. See table I for specific gravity requirements at various temperatures. The pellet that comes with the engine is a water conditioner and rust inhibitor. Do not remove the pellet.
- e. Fill the fuel tank (6, fig. 2). Be sure that the container used for filling is clean and free from dirt. Replace the fuel tank filler cap (3, fig. 4) securely.
- f. See that all points on engine accessories requiring lubrication are properly supplied. Refer to the lubrication order (fig. 14).

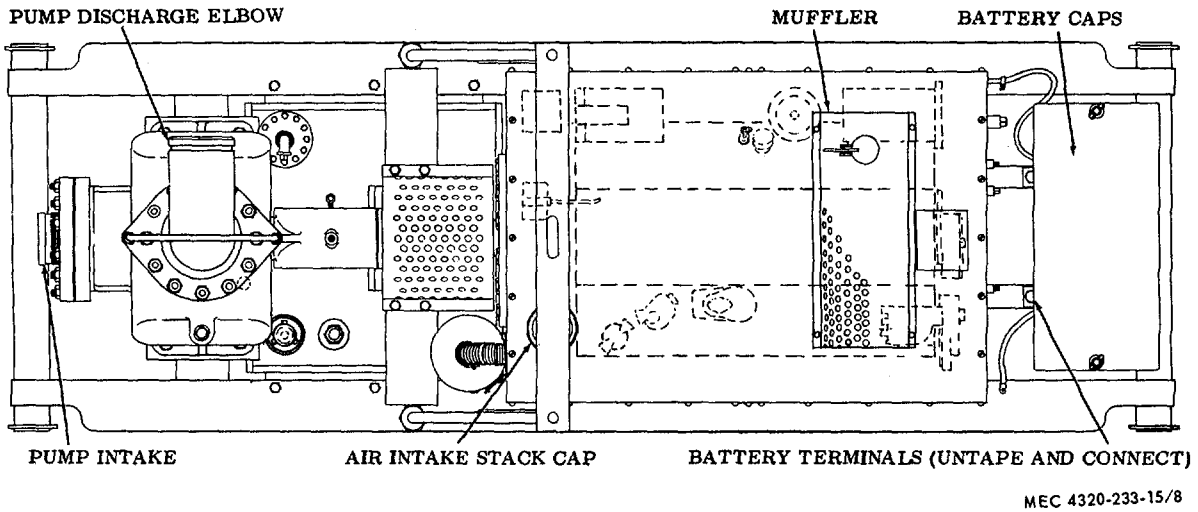

Figure 8. Areas of pump from which packing must be removed.

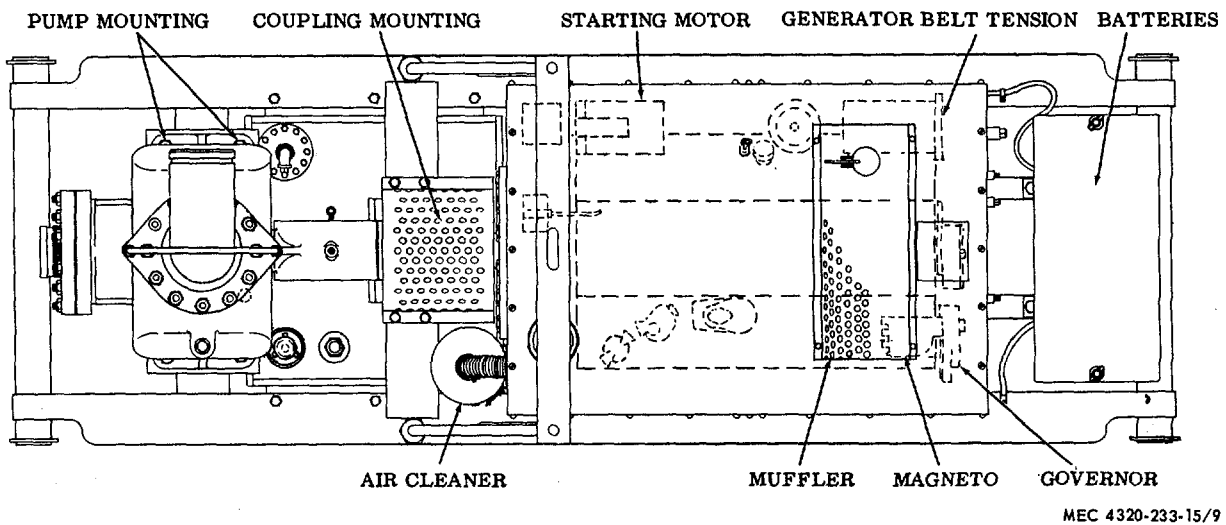

Figure 9. Areas of pump requiring inspection.

g. Check storage battery terminals and all electrical connections. Check each spark plug wire for tightness. Refer to the wiring diagram (fig. 5) and to paragraphs 65 and 71.

## 10. Installation Instructions

### a. Suction Line.

- (1) *Capacity.* Install the pump to keep the suction lift as low as possible and the suction line as short as possible. Reduction in the capacity of self-priming pumps becomes noticeable at lifts in excess of 15 feet and is very pronounced at 25 feet. Do

not use a centrifugal pump for suction lifts in excess of 25 feet.

- (2) *Size of line* The required diameter of suction lines is dependent upon three factors: capacity required, the length of the suction line plus the fittings therein when reduced to the friction loss equivalent of straight pipe, and the actual or static suction lift. Provide a line diameter which considers these factors.
- (3) *Air Pockets* The highest point in the suction line should be at the pump, and the line should be laid on a gradual decline, not



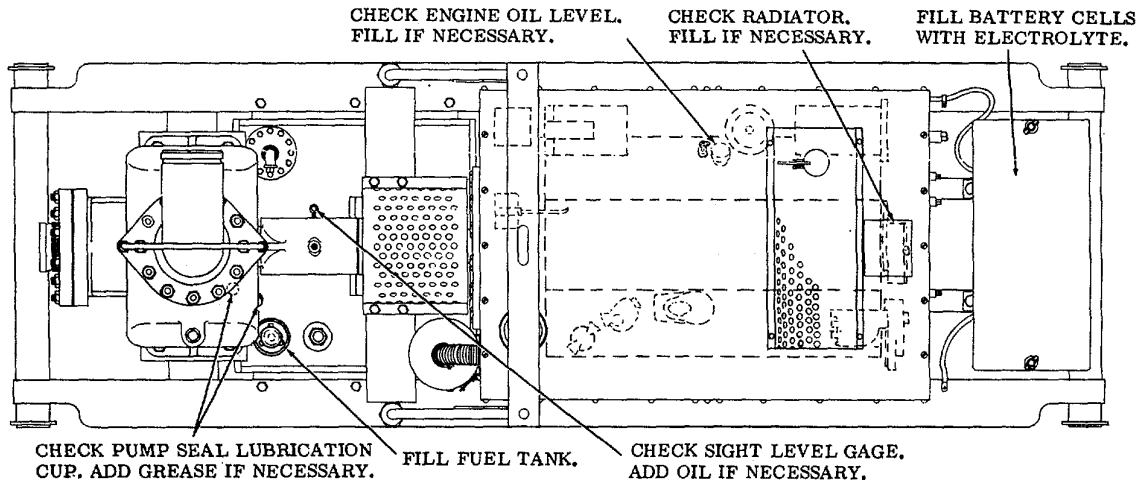

MEC 4320-233-15/10

**Figure 10. Areas of pump requiring servicing.**

even on the level. Avoid high points which will form air pockets. If the pump is operated at a high suction lift, use extra care to see that the hose connections and pipe joints in the suction line are air tight. A small air leak in the suction line may prevent pump priming.

- (4) *Piping* Unless the piping is well supported install a section of hose between the piping and pump as close as possible to the pump. Use a wire-encased rubber suction hose that will not collapse. If the pump is located so that the suction hose is sharply inclined from the pump, install a 45° or 90° elbow in the suction line to prevent a sharp bend in the suction hose. Breaks or air leaks often develop at the point of a sharp bend.

*b. Discharge Line* Friction loss should be given careful consideration. If the fluid is pumped a long distance, increase the size of the pipe to prevent pipe friction from becoming excessive.

**Warning**

**Do not operate the centrifugal pump in an enclosed area without venting the exhaust gases to the outside. Exhaust fumes contain carbon monoxide, and odorless, colorless, deadly poison.**

- c. Exhaust Piping* If the pumping unit is installed indoors, provide piping to carry exhaust

gases to the outside of the building. Make sure that the exhaust piping has a large enough diameter to prevent excessive exhaust back pressure in the engine.

**Table I. Freezing Points, Composition, and Specific Gravities of Military Antifreeze Materials**

Lowest expected ambient temperature °F.	Pints of inhibited glycol per gallon of coolant <sup>1</sup>	Compound, antifreeze Arctic <sup>2</sup>	Ethylene glycol coolant solution specific gravity at 68° F. <sup>3</sup>
+20	1 1/2	Issued full strength and ready mixed for 0° to -65° F. temperatures for both initial installation and replenishment of losses.	1.022
+10	2		1.036
0	2 3/4		1.047
-10	3 1/4		1.055
-20	3 1/2		1.062
-30	4		1.067
-40	4 1/4	DO NOT DILUTE WITH WATER OR ANY OTHER SUBSTANCE.	1.073
-50	Arctic Antifreeze preferred		
-60			
-75			

<sup>1</sup>Maximum protection is obtained at 60 percent by volume (4.8 pints of ethylene glycol per gallon of solution).

<sup>2</sup> Military Specifications MIL-C-11755 Arctic type, nonvolatile antifreeze compound is intended for use in the cooling system of liquid-cooled internal combustion engines. It is used for protection against freezing primarily in Arctic regions where the ambient temperature remains for extended periods close to -40° F. or drops below, to as low as -90° F.

<sup>3</sup> Use an accurate hydrometer. To test hydrometer, use 1 part ethylene glycol antifreeze to 2 parts water. This should produce a hydrometer reading of 0° F.

Note. Fasten a tag near the radiator filler cap indicating the type antifreeze.

## 11. Movement to a New Worksite

### a. Short Distance Move.

- (1) Disconnect the intake and discharge hoses or piping from the pump. Remove the pump drain plug (4, fig. 4) to drain the pump; replace the plug.
- (2) Perform the daily preventive maintenance services (para 36).
- (3) Close the engine and instrument panels.
- (4) Make sure all on-equipment tools are present, clean, and properly stowed.
- (5) Connect a cable or chain from the towing vehicle to the round bar at the front of the skid base; slide the pump to the new location.

### b. Long Distance Move.

- (1) Disconnect the intake and discharge hoses or piping from the pump. Remove the pump drain plug (4, fig. 4) to drain the pump; replace the plug.
- (2) Drain the radiator and coolant lines (para 76), engine oil pan (para 117), fuel tank (para 63a) and carburetor (para 59b(1)).
- (3) Thoroughly steam-clean exterior of pump.
- (4) Make sure that the fuel tank cap, radiator cap, oil drain plug, coolant drain plugs, and all pump plugs are securely tightened.
- (5) Disconnect battery cables. Tape cable terminals and lay cables in the battery box to prevent shorting and electrical contact.
- (6) Secure the engine and instrument panels.

## Section II. CONTROLS AND INSTRUMENTS

### 12. General

The controls and instruments necessary to operate the pumping unit are illustrated in figure 11 and described in paragraphs 13 through 24.

### 13. Tachometer and Hourmeter

The tachometer and hourmeter (1, fig. 11) is located at the upper left of the instrument panel. It indicates the engine speed in rpm, and the total number of engine hours. Normal engine operating speed is 1,800 rpm. The tachometer is geared to register 1 hour when the engine has turned over 108,000 rpm (1,800 rpm x 60 min). By keeping track of the hourmeter readings, it is easy to determine the correct service and lubrication intervals.

### 14. Engine Water Temperature Gage and Safety Switch

a. The engine water temperature gage and safety switch (3, fig. 11) is mounted on the top left center of the instrument panel. The gage indicates the temperature of the cooling fluid in the engine. When the engine is at its normal operating temperature, the needle should indicate between 150° and 185° F.

b. The gage incorporates a temperature safety switch designed to shut the engine down if the temperature of the coolant exceeds a safe operating level. The switch will permit starting of the engine when the temperature of the coolant drops to a safe level.

**15. Ammeter** The ammeter (4, fig. 11) is located at the top right center of the instrument panel. It indicates the

rate of charge or discharge of the batteries. The pointer on the ammeter deflects to the right to indicate charge, and to the left to indicate discharge. After starting, the ammeter will indicate a high rate of charge until the batteries are restored to full charge. After the unit has been inoperative for an extended period of time, the high charging time will be considerably longer after starting. During normal operation, the ammeter should indicate a slight charge rate.

### 16. Engine Oil Pressure Gage and Safety Switch

a. The engine oil pressure gage and safety switch (7, fig. 11) is located at the top right of the instrument panel. It indicates the oil pressure of the engine lubrication system. The normal oil pressure reading when the engine is running at 1,800 rpm and at normal operating temperature is between 40 and 50 psi. (pounds per square inch). The normal oil pressure reading at idle speed (400 to 600 rpm) is over 7 psi.

b. The engine oil pressure gage includes an integral oil pressure safety switch which automatically shuts off the engine if oil pressure drops below the pressure required for safe engine operation. It includes a reset button (6) at the bottom of the gage. To start the engine after low pressure shutdown, first determine and correct the cause of the failure; press the reset button before starting the engine, following normal starting procedures.

### 17. Throttle Control

The throttle control (5, fig. 11) is located at the right center of the instrument panel. It provides a

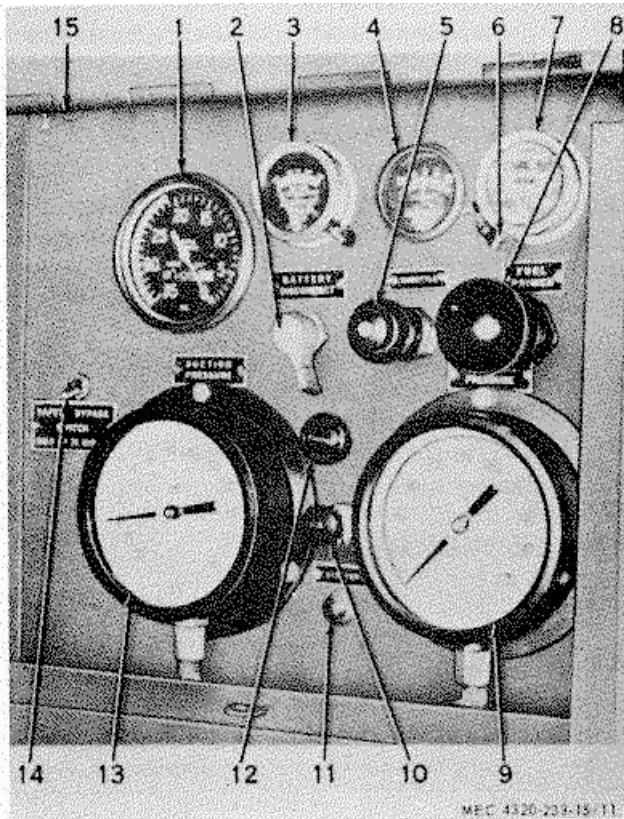

- |  |   |
|--|---|
| 1. Tachometer and hourmeter                        | 7. Engine oil pressure gage and safety switch |
| 2. Battery disconnect switch                       | 8. Fuel primer pump handle                    |
| 3. Engine water temperature gage and safety switch | 9. Discharge pressure gage                    |
| 4. Ammeter   | 10. Magneto switch                            |
| 5. Throttle control                                | 11. Starter button                            |
| 6. G Reset button                                  | 12. Choke control                             |
|  | 13. Intake pressure gage                      |
|  | 14. Safety bypass switch                      |
|  | 15. Panel light                               |

**Figure 11. Controls and instruments.**

means of adjusting engine speed. Pushing the lever to the full-in position produces full speed. Pulling the lever to full-out position produces idle speed.

### 18. Fuel Primer Pump Handle

The fuel primer pump handle (8, fig. 11) is located at the right side of the instrument panel. It operates the primer pump used to pump gasoline into the intake manifold for cold weather starting. When ambient temperatures are below freezing, pump the handle five or six times before starting. Leave the handle in full-in position while the pumping unit is operating.

### 19. Discharge Pressure Gage

The discharge pressure gage (9, fig. 11) is located at the lower right of the instrument panel. It indicates pressures on the discharge side of the pump. Normal gage readings are from 0 to 300 psi.

### 20. Magneto Switch

The magneto switch (10, fig. 11) is located at the lower center of the instrument panel. When pulled out it closes the magneto circuit. Pull out before starting the engine. Push in to shut off the engine.

### 21. Starter Button

The starter button (11, fig. 11) is located at the lower center of the instrument panel. When depressed, it completes a circuit that actuates the starter solenoid. When the starter solenoid is closed, a circuit from the batteries to the starting motor is completed, and the starting motor cranks the engine. Both solenoid and starting motor circuits are broken when the starter button is released.

### 22. Intake Pressure Gage

The intake pressure gage (13, fig. 11) is located at the lower left of the instrument panel. It indicates the pressure or vacuum at the intake side of the pump. Normal readings are from 30 inches of mercury vacuum to 100 psi pressure.

### 23. Choke Control

The choke control (12, fig. 11) is located at the center of the instrument panel. It is mechanically connected to the carburetor choke lever. The choke is fully closed when the choke control knob is pulled out as far as it will go; the choke is open when the knob is pushed in as far as it will go. Close the choke to facilitate starting a cold engine. As the engine temperature rises, operate the choke to the open position until it is fully opened when engine temperature rises to normal.

### 24. Battery Disconnect Switch

The battery disconnect switch (2, fig. 11) is located at the left center of the instrument panel. When opened, it breaks the circuit between the batteries and the starting motor. The switch must be in the ON position when the pumping unit is being started or is operating.

#### 24.1. Liquid Level Gage

The liquid level gage (7, fig. 2) is located in the fuel tank (6). It indicates the level of the fuel in the tank.

## 24.2. Safety Bypass Switch

The safety bypass switch (14, fig. 11) provides a means of overriding the control that automatically

shuts down the engine if conditions of excessive water temperature or low oil pressure are encountered.

### Section III. OPERATION UNDER USUAL CONDITIONS

#### 25. Starting

a. Perform the daily preventive maintenance services (para 36).

b. Make sure the valves in both the intake and discharge lines are open.

c. Start the engine as directed in figure 12.

#### Note

**Prime the pump as directed in paragraph 27a(1) before starting the engine.**

#### 26. Stopping

a. Stop the engine as directed, in figure 13

b. Perform the daily preventive maintenance (para 36).

#### 27. Operating Details

a. Preliminary Steps To Be Taken Before Starting the Equipment.

- (1) Prime the pump by removing the primer port plug (7, fig. 4) and filling the pump casing with the fluid being pumped. Fill until fluid reaches the top of the priming port. Reinstall the plug.

#### Caution

**Never operate the engine without first priming the pump.**

- (2) Perform the daily preventive maintenance services (para 36).

b. *Starting the Equipment.*

- (1) Start the engine (para 25).
- (2) After the engine has warmed up, push in the throttle (5, fig. 11) so that the engine

operates at governed speed (approx. 1,800 rpm).

- (3) The pump should prime and pump within 5 minutes. If the engine runs for more than 5 minutes without pumping, there is probably a mechanical defect. Shut down the pump engine; check for leaks in the intake lines and check for other defects.

- (4) Maintain a check of the intake pressure gage (13) and of the discharge pressure gage (9) to assure that the pump is operating within normal capabilities. If gages read incorrect refer to organizational maintenance.

c. *Position of Controls.*

- (1) Increase or decrease the pumping rate of the pump by varying the setting of the throttle (5). No other control operation is necessary during operation.

- (2) Do not completely close any valves in the discharge line. This will cause heating of the fluid in the pump. Make sure that some passage of fluid continues through the pump during operation.

d. *Details on Performance of Pump.*

- (1) Pump performance at 1,800 rpm and at normal elevations must be as indicated in paragraph 5k.

- (2) For operations at higher elevations, refer to paragraph 33.

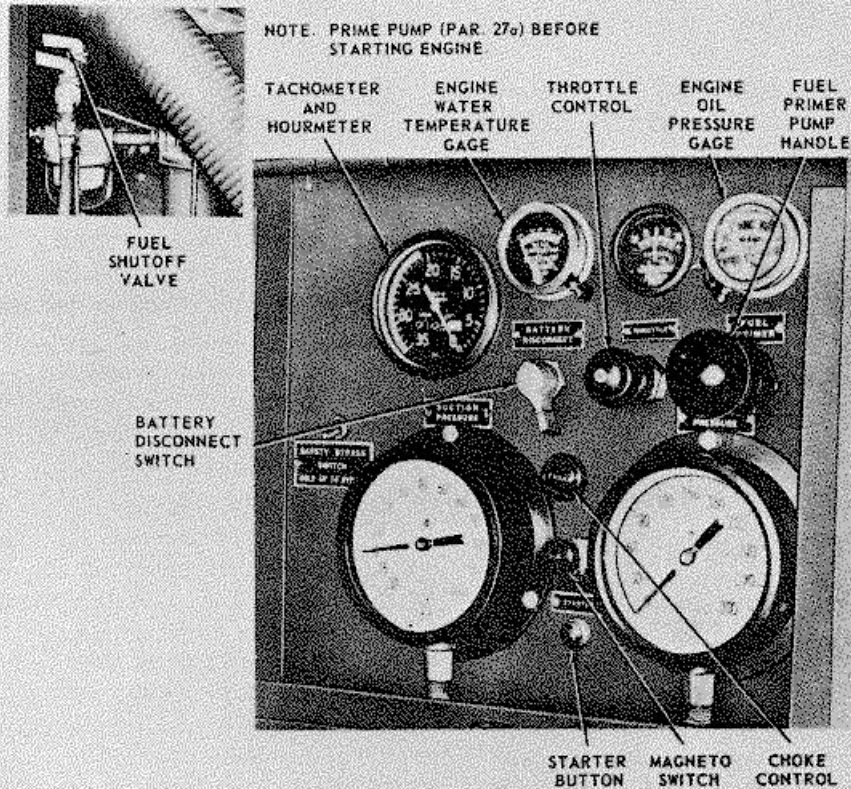

1. OPEN FUEL SHUTOFF VALVE.
2. PULL OUT MAGNETO SWITCH.
3. PULL OUT CHOKE CONTROL ONE-HALF WAY.
4. PUSH IN THROTTLE CONTROL ONE-HALF WAY.
5. OPERATE BATTERY DISCONNECT SWITCH TO ON.
6. IN SUBFREEZING TEMPERATURES, USE FUEL PRIMER PUMP HANDLE TO PUMP FUEL INTO INTAKE MANIFOLD. OPERATE HANDLE ABOUT SIX STROKES.
7. PRESS AND HOLD STARTER BUTTON UNTIL ENGINE STARTS. DO NOT EXCEED 15 SECONDS CRANKING TIME AT ANY ONE STARTING ATTEMPT. WAIT 2 MINUTES BETWEEN CRANKING ATTEMPTS.
8. WHEN ENGINE STARTS, ADJUST THROTTLE CONTROL UNTIL TACHOMETER AND HOURMETER INDICATES APPROXIMATELY 700 RPM. RUN AT THIS SPEED FOR SEVERAL MINUTES. ADJUST CHOKE CONTROL TO MAINTAIN SMOOTH ENGINE OPERATION AS ENGINE WARMS UP.
9. CHECK ENGINE OIL PRESSURE GAGE READING AT IDLE SPEED. GAGE MUST INDICATE 7 PSI MINIMUM.
10. ADJUST THROTTLE CONTROL UNTIL 900 TO 1000 RPM IS INDICATED ON TACHOMETER AND HOURMETER. OPERATE AT THIS SPEED UNTIL ENGINE WATER TEMPERATURE GAGE INDICATES AT LEAST 100°F. CONTINUE TO ADJUST CHOKE CONTROL UNTIL ENGINE RUNS SMOOTHLY WITH CHOKE CONTROL FULLY IN.

MEC 4320-233-15/12

Figure 12. Starting procedure.

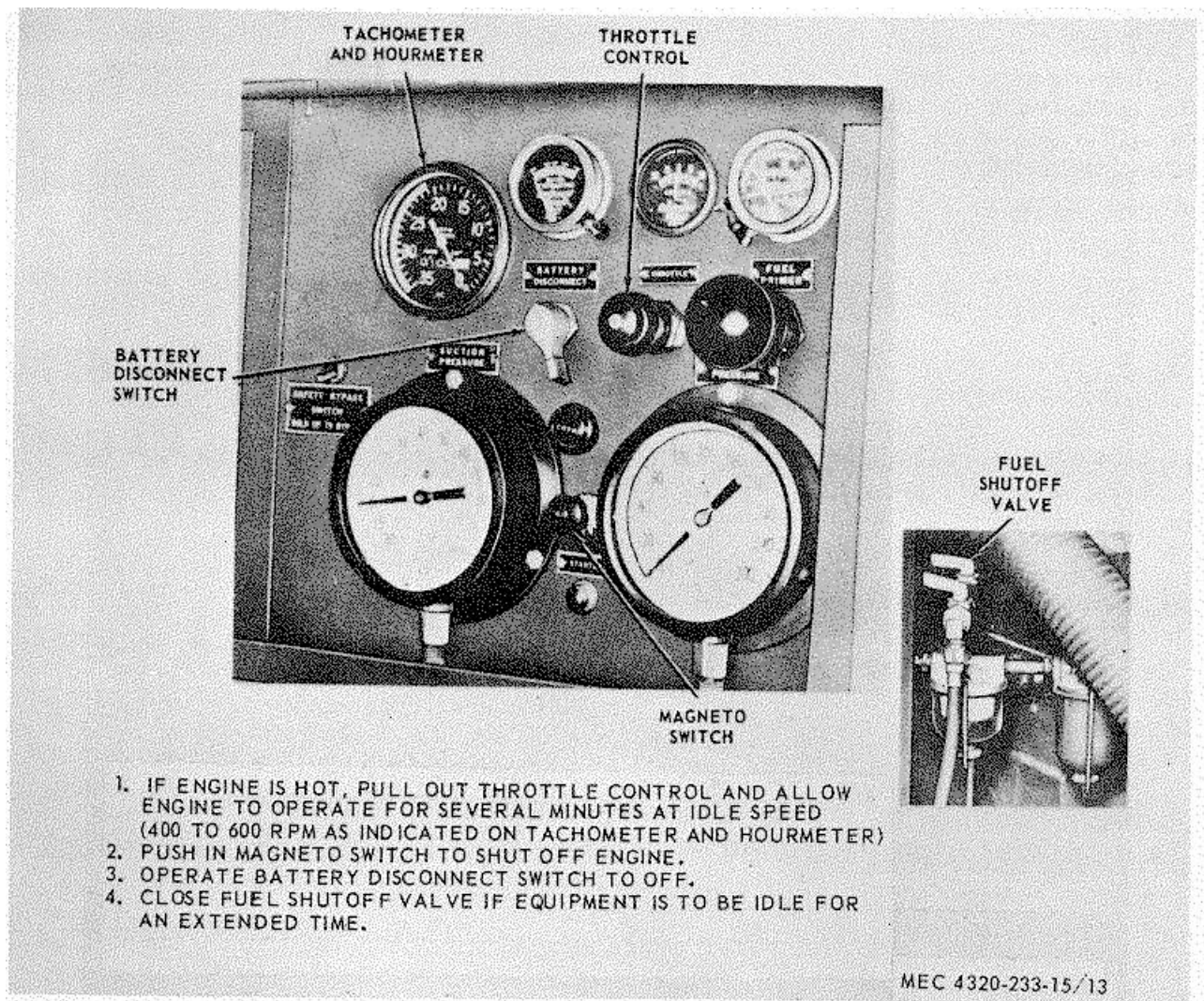

**Figure 13. Stopping procedure.**  
**Section IV. OPERATION UNDER SENSUAL -CONDITIONS**

**28. Extreme Cold (Below Freezing)**

a. *General* Take special precautions and provide extra servicing necessary to maintain the operation of the pumping unit in subfreezing temperatures.

b. *Fuel System* Keep the fuel tank as full as possible to keep water in the air from condensing in the fuel tank. Use the fuel primer pump to keep the fuel system free of air pockets and to decrease the chance of ice formation in the fuel system. Service the fuel sediment bowl and fuel strainer daily (pare 58a).

c. *Lubrication* Lubricate the pumping unit as directed in the current lubrication order (fig. 14).

d. *Coolant System* Maintain a proper amount of antifreeze in the engine coolant. Refer to table I for the correct antifreeze mixture. Before in stalling antifreeze, clean and flush the coolant system as directed in paragraph 76. Check carefully for coolant leaks.

e. *Electrical System* Keep electrical components free of ice and moisture. Avoid unnecessary handling of electrical wiring during extreme cold. Wiring becomes brittle and is easily damaged and cracked. Maintain the batteries at full charge to

increase their efficiency and lessen the possibility of damage due to extreme cold.

**Caution**

**Run the engine for at least 1 hour after adding water to battery electrolyte. This will allow water and electrolyte to mix thoroughly and prevent freezing.**

**29. Extreme Heat**

*a. General* Provide special servicing and take necessary precautions when operating the pumping unit in extremely high temperatures. Provide adequate ventilation when operating the unit indoors.

*b. Fuel System* Do not fill the fuel tank completely to the top. Allow room for expansion of fuel as it heats to ambient temperatures.

*c. Lubrication* Lubricate the pumping unit as directed in the current lubrication order (fig. 14).

*d. Coolant System* Maintain a sufficient supply of coolant in the radiator at all times. Keep the coolant system free of rust and scale by using only soft water with an approved rust inhibitor. Make sure that the thermostat is providing proper temperature control of the engine coolant. Check the fan belts for proper adjustment. Make sure that the radiator fins are free from dirt, corrosion, insects, and other matter that could reduce cooling efficiency. Adjust the fan belts (para 67a) if necessary.

**30. Dusty or Sandy Areas**

*a. General.* If the pumping unit is permanently installed, provide a protective shelter for it. For temporary installation, take advantage of natural barriers to protect the unit as much as possible. Keep side panels and the instrument panel cover closed. Keep the unit free of sand and dirt, taking special care to keep radiator cores clean.

*b. Lubrication* In sandy and dusty areas, service the oil filter more frequently than directed in the lubrication order (fig. 14). Clean all lubrication points before and after lubrication. Keep containers tightly sealed and stored in a dust-free area.

*c. Fuel System* Take care to prevent the entry of dust and grit into the fuel system. Clean the fuel strainer and sediment bowl frequently. Take special precautions to keep the air cleaner properly serviced. Experience will dictate the servicing interval required.

**31. Salt Water or High Humidity**

*a. Salt Water* Salt water has a highly corrosive effect on metals. Prevent contact of salt water with the unit whenever possible. If unit is exposed to salt water, wash with fresh water after every exposure.

**Caution**

**Never use salt water in the coolant system of the engine. This will cause extreme corrosion and will greatly limit life of engine.**

*b. High Humidity* If the pumping unit is installed outdoors in conditions of high humidity, erect a shelter, if possible, to protect the unit. If the erection of a shelter is not possible, cover the unit with a tarpaulin or other vapor-barrier material when the pumping unit is inoperative. During dry periods, remove side panels to allow engine components to dry. Maintain a full fuel level in the fuel tank to prevent the formation of condensation.

*c. Painting* In salt water or high humidity areas, take special precautions to keep the unit painted properly. Paint all exposed metal surfaces. Coat all exposed polished metal surfaces with standard issue rustproofing materials, if available, or apply a light coat of grease. Refer to TM 9-213 for preservation and painting instructions.

**32. High Altitudes**

*a. General* As altitudes increase, the thinning of the air decreases engine efficiency so that power output drops approximately 312 percent for each 1,000 feet of elevation. Because of the reduced external pressures, suction lifts decrease and pumping efficiency is also greatly reduced. Refer to table II. For these reasons, it is highly important to maintain all other systems at the peak of efficiency to assure that all available power is applied to the pump.

**Table II. Pump Efficiency at Varying Elevations**

Altitude (ft)	Percentage of sea	
	level discharge	level head
Sea level.....	100	100
2,000 ft.....	97	95
4,000 ft.....	95	91
6,000 ft.....	93	87
8,000 ft.....	91	83
10,000 ft.....	88	78

*b. Carburetor* Decreased air pressure at high altitudes upsets the calibration of the carburetor, causing an excessively rich full-air mixture. Adjust the carburetor as directed in paragraph 59a.

*c. Air Cleaner* Take care that the air cleaner is operating at its optimum efficiency to allow the engine to take in as much of the available air as possible. Service the air cleaner as necessary (para 60).

*d. Ventilation* Provide an adequate fresh air supply to keep the engine of the pumping unit from overheating.

**CHAPTER 3**  
**OPERATOR AND ORGANIZATIONAL MAINTENANCE INSTRUCTIONS**

---

**Section I. SPECIAL TOOLS AND LUBRICANTS**

**33. Special Tools and Equipment**

No special tools or equipment are required by the operator or organizational maintenance personnel for the maintenance of this centrifugal pumping unit.

**33.1 Basic Issue Tools and Equipment**

Tools and repair parts issued with or authorized for the centrifugal pump are listed in the basic issue items list, appendix II, of this manual.

**33.2. Organizational Maintenance Repair Parts**

Organizational maintenance repair parts are listed and illustrated in TM 5-4320-233-25P.

**34. Lubrication Information**

(fig. 14)

*a. Care of Lubricants* Keep all lubricants in closed containers and store in a clean, dry place away from external heat. Allow no dust, dirt, water, or other foreign material to mix with the lubricants. Keep all lubrication equipment clean and ready for use.

*b. Cleaning* Keep all external parts, not requiring lubrication, clean of lubricants. Before lubricating the equipment, wipe all lubrication points free of dirt and grease. Clean all lubrication points after lubricating to prevent the accumulation of foreign matter.

*c. Operation Immediately After Lubrication* Operate the engine immediately after lubrication. Inspect the oil filter, oil lines, and other connections which might cause oil leakage. If the crankcase oil has been changed, operate the engine for approximately 5 minutes before checking the oil level.

*d. Oil Filter.* Service the oil filter as directed in paragraph 78.

*e. Air Cleaner.* Service the air cleaner as directed in paragraph 60.

*f. Bearing* Pump bearing housing sight glass should show 1/3 full.

*g. Coupling* Pump coupling should be repacked with GAA whenever coupling is removed.



**LUBRICATION  
ORDER**

**L05-4320-233-15**

28 DECEMBER 1965

**PUMP, CENTRIFUGAL. GASOLINE DRIVEN, SKID MOUNTED  
6 IN.; 1120 GPM, SELF PRIMING (CARVER MODEL  
K906 EWA) W/ENGINE CONTINENTAL  
MODEL MS330-6065P**

Reference: C9100-IL

Intervals are based on normal hours of operations. Reduce to compensate for abnormal operations and severe conditions. During inactive periods sufficient lubrication must be performed for adequate preservation.

Clean parts with SOLVENT, dry-cleaning, or with OIL, fuel, Diesel. Dry before lubricating.

Relubricate after washing.

Drain crankcase and pump bearing housing when hot. Fill and check level.

Clean fittings before lubricating.

FOLD

FOLD

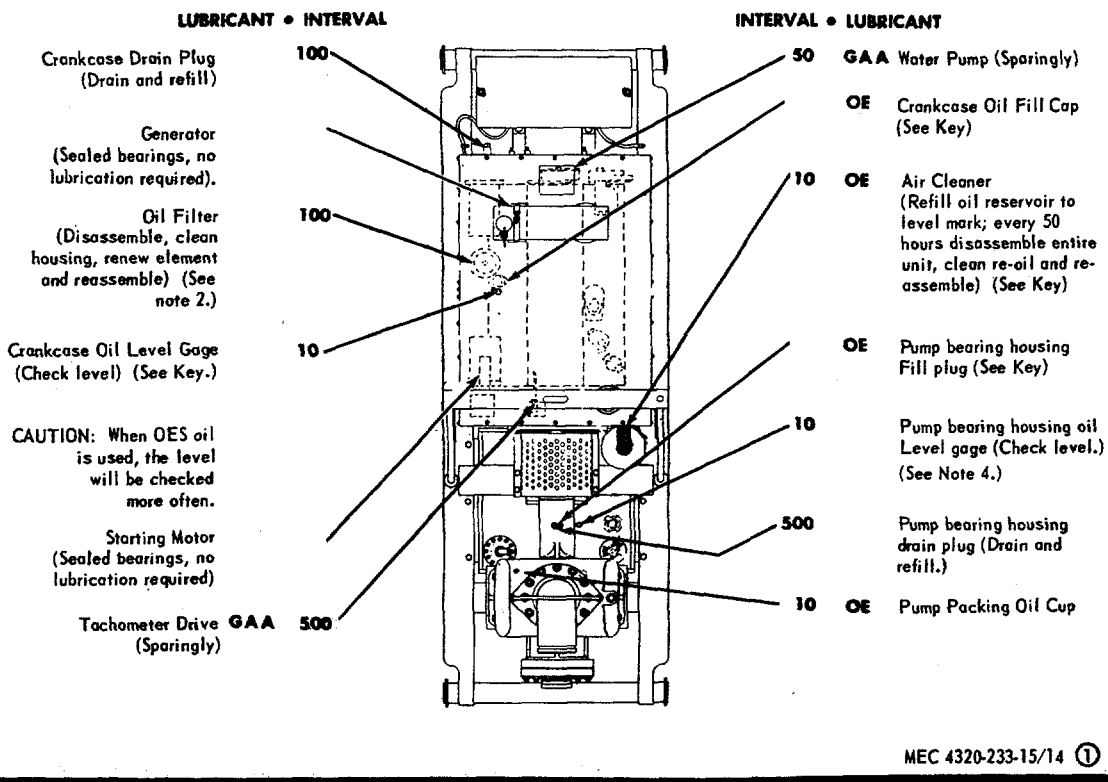

MEC 4320-233-15/14 ①

Figure 14. Lubrication order.

- KEY -

LUBRICANTS	CAPACITY	EXPECTED TEMPERATURES			INTERVALS
		Above +32°F	+40°F to -10°F	0°F to -65°F	
<b>OE - OIL, Engine, Heavy Duty</b>		OE 30	OE 10	OES	Intervals given are in hours of normal operation.
Crankcase	8qt				
Air Cleaner	1qt				
Pump Bearing Housing	1/2qt				
Oil Can Points					
<b>OES - OIL, Engine, Sub-zero</b>		All Temperatures			
<b>GAA - GREASE, Automotive and Artillery</b>		All Temperatures			

NOTES:

1. FOR OPERATION OF EQUIPMENT IN PROTRACTED COLD TEMPERATURES BELOW -10°F. Remove lubricants prescribed in the key for temperatures above -10°F. Clean parts with SOLVENT, Dry-cleaning. Relubricate with lubricants specified in the key for temperatures below -10°F.

2. OIL FILTERS. After installing new filter elements, fill crankcase, operate engine 5 minutes, check housing for leaks, check crankcase oil level and bring to full mark.

3. OIL CAN POINTS. Every 10 hours fill pump packing oil cup with OE, every 50 hours clean and lightly coat throttle and choke linkage with OE, every 250 hours oil magneto cam wick sparingly with OE.

4. PUMP BEARING HOUSING. Oil level should show 1/3 full in level sight glass.

Copy of this Lubrication Order will remain with the equipment at all times; instructions contained herein are mandatory.

BY ORDER OF THE SECRETARY OF THE ARMY:

HAROLD K. JOHNSON  
General, United States Army,  
Chief of Staff.

OFFICIAL:

J. C. LAMBERT,  
Major General, United States Army,  
The Adjutant General.

FOLD

FOLD

MEC 4320-233-15/14 ②

Figure 14-Continued.

## Section II. PREVENTIVE MAINTENANCE SERVICES

### 35. General

To insure that the centrifugal pump is ready for operation at all times, it must be inspected systematically, so that defects may be discovered and corrected before they result in serious damage or failure. The necessary preventive maintenance services to be performed are listed and described in paragraphs 36 and 37. The item numbers indicate the sequence of minimum inspection requirements. Defects discovered during operation of the unit shall be noted for future correction, to be made as soon as operation has ceased. Stop operation immediately if a deficiency is noticed during operation, which would damage the equipment if operation were continued. All deficiencies and shortcomings will be recorded together with the corrective action taken on DA Form 2404 (equipment inspection and maintenance worksheet) at the earliest possible opportunity.

TAGO 6358A

### 36. Daily Preventive Maintenance Services

This paragraph contains an illustrated tabulated listing of preventive maintenance services which must be performed by the operator. The item numbers are listed consecutively and indicate the sequence of minimum requirements. Refer to figure 15 for the daily preventive maintenance services:

### 37. Quarterly Preventive Maintenance Services

a. This paragraph contains an illustrated tabulated listing of preventive maintenance services which must be performed by organizational maintenance personnel at quarterly intervals. A quarterly interval is equal to 3 calendar months, or 250 hours of operation, whichever occurs first.

b. The item numbers are listed consecutively and indicate the sequence of minimum requirements. Refer to figure 16 for the quarterly preventive maintenance services.

# PREVENTIVE MAINTENANCE SERVICES

## DAILY

TM 5-4320-233-15

CARVER PUMP CO.  
MODEL K906EWA

PUMP CENTRIFUGAL

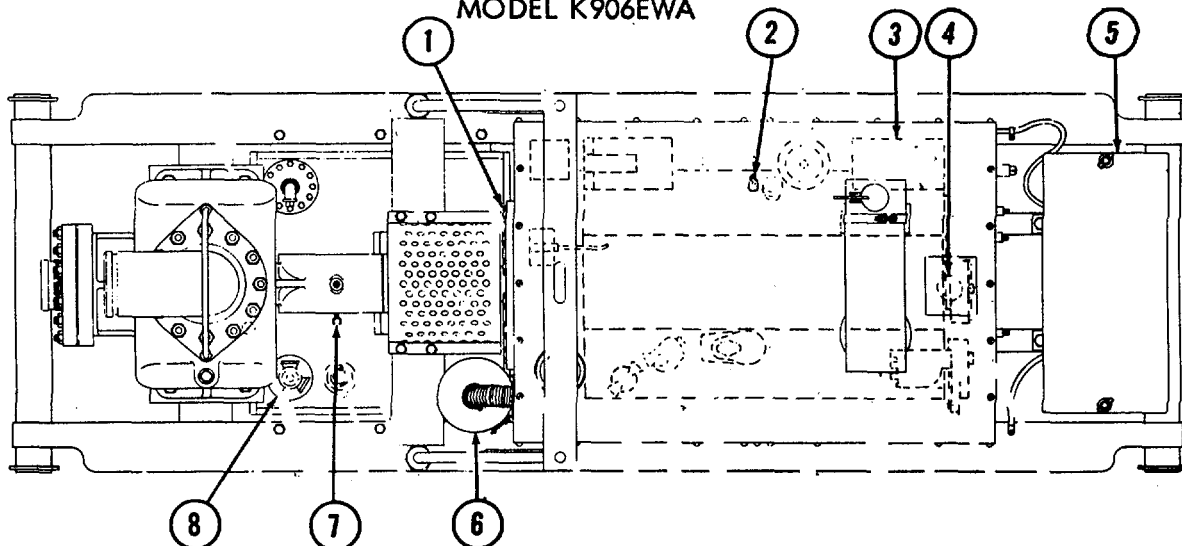

LUBRICATE IN ACCORDANCE WITH CURRENT LUBRICATION ORDER

ITEM

PAR REF

1	<p><b>CONTROLS AND INSTRUMENTS.</b> Inspect for damage and loose mounting. With unit operating, check for proper operation. Normal operating readings for instruments are as follows:</p> <table border="0"> <tr> <td>Engine Water Temperature Gage</td> <td>150° to 180° F.</td> </tr> <tr> <td>Engine Oil Pressure Gage</td> <td>40 to 50 psi at governed speed.</td> </tr> <tr> <td>Ammeter</td> <td>+ side of zero</td> </tr> <tr> <td>Pump Discharge Pressure Gage</td> <td>0 to 300 psi</td> </tr> <tr> <td>Pump Intake Pressure Gage</td> <td>30 in. of mercury to 100 psi</td> </tr> </table>	Engine Water Temperature Gage	150° to 180° F.	Engine Oil Pressure Gage	40 to 50 psi at governed speed.	Ammeter	+ side of zero	Pump Discharge Pressure Gage	0 to 300 psi	Pump Intake Pressure Gage	30 in. of mercury to 100 psi	87-92
Engine Water Temperature Gage	150° to 180° F.											
Engine Oil Pressure Gage	40 to 50 psi at governed speed.											
Ammeter	+ side of zero											
Pump Discharge Pressure Gage	0 to 300 psi											
Pump Intake Pressure Gage	30 in. of mercury to 100 psi											
2	<p><b>OIL LEVEL GAGE.</b> Add oil as indicated by level gage. Reference current Lubrication Order.</p>											
3	<p><b>BELT.</b> Proper adjustment is a deflection of 3/4 inch midway between pulleys.</p>	67										
4	<p><b>RADIATOR.</b> Proper coolant level is 1 inch below filler neck.</p>	76										

MEC 4320-233-15/15 ①

Figure 16. Daily preventive maintenance services.

ITEM		PAR REF
5	<u>BATTERIES.</u> Tighten loose cables and mountings. Remove corrosion. Inspect for cracks and leaks. Fill to 3/8 inch above the plates. Clean vent hole in filler cap before installing. In freezing weather run engine a minimum of 1 hour after adding water. (Weekly)	65
6	<u>AIR CLEANER.</u> Check for proper oil level Reference current Lubrication Order.	60
7	<u>SIGHT LEVEL GAGE.</u> Check for loose mounting, broken glass and for incorrect oil level.	
8	<u>FUEL TANK.</u> Add fuel as required .	63
	<u>NOTE 1. OPERATION.</u> During operation observe for any unusual noise or vibration.	

MEC 4320-233-15/15 (2)

Figure 15-Continued.

# PREVENTIVE MAINTENANCE SERVICES

## QUARTERLY

TM 5-4320-233-15

CARVER PUMP CO.  
MODEL K906EWA

PUMP CENTRIFUGAL

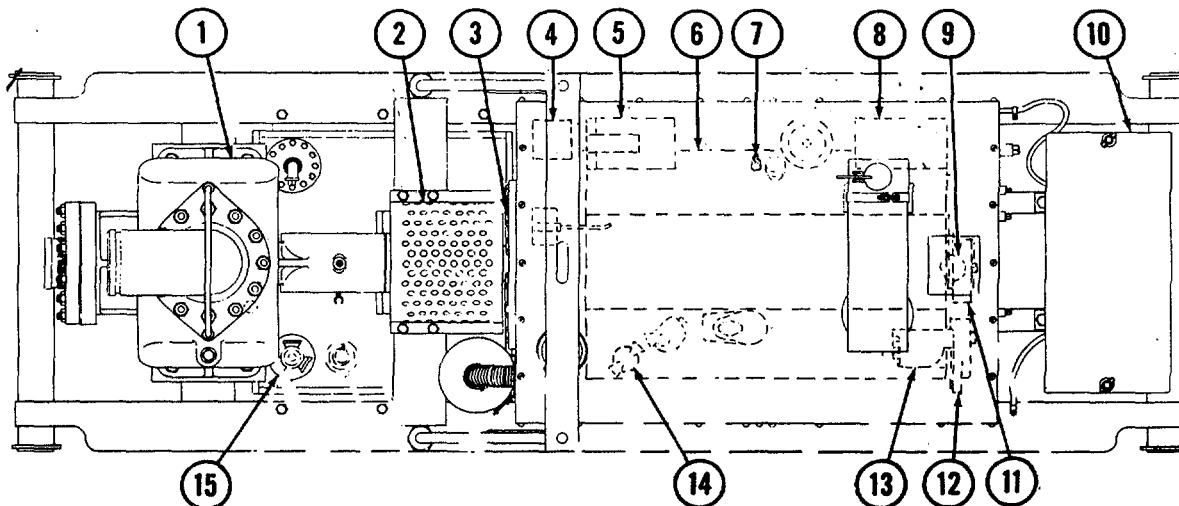

LUBRICATE IN ACCORDANCE WITH CURRENT LUBRICATION ORDER

ITEM		PAR REF
1	<u>PUMP ASSEMBLY.</u> Inspect for loose mounting, leaks, noisy operation, over heating, failure to prime easily, and vibration.	101
2	<u>COUPLING.</u> Check for looseness, lubricant leakage through seals and vibration.	100
3	<u>CONTROLS AND INSTRUMENTS.</u> Inspect for damage and loose mounting. With unit operating, check for proper operation. Normal operating readings for instruments are as follows: Engine Water Temperature Gage      150° to 180° F. Engine Oil Pressure Gage              40 to 50 psi at governed speed. Ammeter                                      + side of zero. Pump Discharge Pressure Gage        0 to 300 psi. Pump Intake Pressure Gage            30 in. of mercury to 100 psi.	87-92
4	<u>VOLTAGE REGULATOR.</u> Check for loose mounting. Adjust or replace as necessary.	68

MEC 4320-233-15/16 ①

Figure 16. Quarterly preventive maintenance services.

ITEM		PAR REF
5	<u>STARTING MOTOR.</u> Check for loose mounting, leads and improper drive alignment. Replace as necessary.	69
6	<u>CYLINDER HEAD.</u> Check for coolant leaks.	115
7	<u>OIL LEVEL GAGE.</u> Add oil as indicated by level gage. Reference current Lubrication Order.	
8	<u>BELT.</u> Proper adjustment is a deflection of 3/4 inch midway between pull-eyes. Replace a defective belt.	67
9	<u>RADIATOR.</u> Proper coolant level is 1 inch below filler neck. Replace cracked or frayed hose. Replace a defective radiator. Remove obstructions in the air passages. Tighten all mounting or leaking connections.	76
10	<u>BATTERIES.</u> Tighten loose cables and mountings. Remove corrosion. Fill to 3/8 inch above plates. Clean vent hole in filler cap before installing. In freezing weather run engine minimum of 1 hour after adding water. Repair or replace a cracked or leaking battery.	65
11	<u>WATER PUMP.</u> Check for loose bearings or leakage.	74
12	<u>GOVERNOR.</u> Check for loose mounting. Adjust, repair or replace as necessary.	61
13	<u>MAGNETO.</u> Replace pitted or burned magneto points. Proper point gap adjustment is 0.008 to 0.012 inch. (Check adjustment every 500 hours.)	70
14	<u>FUEL STRAINER.</u> Tighten thumb nut if leaking. Clean a dirty strainer element.	57.1
15	<u>FUEL TANK.</u> Add fuel as required. Tighten loose mounting. Replace a leaking fuel tank. Replace defective cap gasket. Clean cap vent.	63
	<u>NOTE 1. OPERATIONAL TEST.</u> During operation observe for any unusual noise or vibration.	
	<u>NOTE 2. ADJUSTMENTS.</u> Make all necessary adjustments during operational test.	

MEC 4320-233-15/16 (2)

Figure 16-Continued.

### Section III. TROUBLESHOOTING

#### 38. General

This section provides information useful in diagnosing and correcting unsatisfactory operation or failure of the centrifugal pump and its components. Each trouble symptom stated is followed by a list of probable causes of the trouble. The possible remedy recommended is described opposite the probable cause. Any trouble beyond the scope of organizational maintenance shall be reported to direct support maintenance.

#### 39. Engine Falls to Start or Hard to Start

<i>Probable cause</i>	<i>Possible remedy</i>
Starter fails to crank engine.	Check and repair electrical system and starting motor (para 69).
Carburetor out of adjustment.	Adjust carburetor (para 59a).
Valves defective.....	Repair or replace valves (para 116).
Spark plugs defective.....	Clean and gap or replace spark plugs (para 71).
Magneto defective.....	Repair or replace magneto (para 70 or 110).

#### 40. Engine Misses or Runs Erratically

<i>Probable cause</i>	<i>Possible remedy</i>
Governor defective	Repair or replace governor (para 61 or 106).
Valves burned, warped, broken.	Repair or replace valves or (para 116).
Valve springs weak or broken.	Replace valve springs (para 116).
Valve seats cracked.....	Replace exhaust valve seat inserts and reface intake valve seats (para 116).
Spark plugs defective.....	Clean and gap or replace spark plugs (para 71).
Magneto defective.....	Repair or replace magneto (para 70 or 110).

#### 41. Engine Noisy

<i>Probable cause</i>	<i>Possible remedy,</i>
Engine mounting bolts loose.	Tighten mounting bolts (para 102).
Flywheel loose or defective.	Tighten or replace flywheel (para 120).
Main or connecting rod bearings loose.	Replace bearings (para 119 and 121).

#### 42. Engine Stops Suddenly

<i>Probable cause</i>	<i>Possible remedy</i>
No fuel in tank.....	Fill fuel tank.
Ignition wiring faulty.....	Check wire from switch to magneto for a possible ground.
Magneto failure.....	Replace or repair magneto (para 70 or 110).
<i>Probable cause</i>	<i>Possible remedy</i>
Oil pressure safety switch trips.	Check oil level; replenish supply if necessary. Reset oil pressure switch. Start

engine and check for oil pressure. If pressure is adequate but switch shuts off engine, replace engine oil pressure gage - and integral safety switch (para 90).

#### 43. Oil Pressure Low

<i>Probable cause</i>	<i>Possible remedy</i>
<b>Caution</b>	
<b>If the engine oil pressure gage does not show a minimum of 7 psi at Idle speed a few seconds after starting, stop the engine and check for cause</b>	
Not enough oil in engine.	Fill to prescribed level.
Engine oil pressure gage faulty.	Replace gage (para 90).
Oil pressure relief valve sticking open.	Remove relief valve; clean valve and hole in block. Reassemble (para 81).
Oil pump screen clogged... (para	Clean oil pump screen (para
	118c).
Oil pump defective.....	Repair or replace oil pump (para 118).
Main or connecting rod bearings loose.	Replace main bearings (para 121). Replace connecting rod bearings (para 119).

#### 44. Engine Overheats

<i>Probable cause</i>	<i>Possible remedy</i>
Thermostat defective.....	Replace thermostat (para 75).
Radiator defective.....	Clean radiator (para 76).
Water pump defective.....	Repair or replace water pump (para 74 or 113).
Cylinder head cracked	Replace cylinder head (para 115).
Crankcase water jacket cracked.	Replace engine block (para 122).

#### 45. Exhaust Smoke Excessive

<i>Probable cause</i>	<i>Possible remedy</i>
Piston rings and/or pistons defective.	Replace piston rings and/or pistons (para 119).

#### 46. Engine Lacks Power

<i>Probable cause</i>	<i>Possible remedy</i>
Governor defective.....	Repair or replace governor (para 61 or 106).
Valves burned, warped, or broken	Repair or replace valves (para 116).
Valve springs weak or broken.	Replace valve spring (para 116).
Valve seats cracked	Replace exhaust valve seat inserts and reface
intake	valve seats (para 116).
Magneto defective.....	Repair or replace magneto (para 70 or 110).
Piston rings and/or pistons defective.	Replace piston rings and/or pistons (para 119).



**47. Generator Fails to Function**

<i>Probable cause</i>	<i>Possible remedy</i>
Generator armature or field windings defective.	Replace armature & field windings (para 108).
Commutator worn, burned, or has high mica.	Turn down commutator and undercut mica (para 108).
Generator regulator out of adjustment or defective.	Adjust generator regulator or replace defective regulator (para 68).
Generator brush holder defective.	Replace defective commutator end frame (para 108).

**48. Starting Motor Does Not Operate Properly**

<i>Probable cause</i>	<i>Possible remedy</i>
Brushes worn.....	Replace brushes.
Starting armature or field windings defective.	Replace armature or field windings (para 109).
Commutator worn, burned, or has high mica.	Turn down commutator and undercut mica (para 109).
Starter shaft and pinion defective.	Replace shaft and pinion (para 109).
Starter brush holders defective.	Replace defective brush holder(para 109).
Starter bearing defective	Replace end bells (para 109).
Flywheel spur gear defective.	Replace spur gear (para 120).

**49. Pump Fails to Prime**

<i>Probable cause</i>	<i>Possible remedy</i>
Air leak in suction line	Tighten hose connections. Check for pinholes in hose. Check for collapsed lining.

<i>Probable cause</i>	<i>Possible remedy</i>
Defective seal.....	Replace seal (para 127).
Suction strainer or suction line plugged.	Clear line or strainer.
Impeller clogged, broken, or worn out.	Clean or replace (para 127).
Chamber not completely filled for priming.	Fill chamber (para 27a).
Check valve not seating properly.	Remove dirt or debris from check valve seat (para 125).

**50. Noisy Pump Operation**

<i>Probable cause</i>	<i>Possible remedy</i>
Impeller broke.....	Replace impeller (para 127).
Pump bearings defective	Replace defective bearings (para 127).
Pump drive shaft defective.	Replace drive shaft (para 127).
Excessively high suction lift causing cavitation.	Move pump closer to supply.

**51. Pump Fails to Deliver Rated Capacity**

<i>Probable cause</i>	<i>Possible remedy</i>
Engine lacks speed.....	Check governor adjustment (para 61a).
Air leak in suction line.....	Tighten connections. Check for pinholes.
Suction lift too high.....	Move pump closer to supply.
Total head too high.....	Rearrange system to reduce elevation between point of delivery and supply.
Impeller partially clogged.	Clean impeller (para 127).

**51.1. Pressure Gages Read Incorrectly or Show No Readings**

<i>Probable cause</i>	<i>Possible remedy</i>
Lines clogged.....	Clean lines (para 99.2).

**Section IV. RADIO INTERFERENCE SUPPRESSION**

**52. Definitions**

*a. Interference* The term "interference" as used in this manual applies to electrical disturbances in the radio-frequency range which are generated by the pump engine and which may interfere with the proper operation of radio receivers or other electronic equipment.

*b. Interference Suppression* The term "Interference suppression" as used in this manual applies to the methods used to eliminate or effectively reduce interference generated by the pump engine.

**53. Purpose**

The tactical importance of effective interference suppression cannot be stressed too greatly. Since the electrical disturbances generated by the pump engine are composed partly of electrical waves in the TAGO 6358-A

radio-frequency range, they must be suppressed for two important reasons. They will interfere with the proper operation of the friendly radio sets, and they will enable the enemy to locate the equipment and its associated units.

**54. General Source of Interference**

Generally, radio interference is generated anywhere a spark occurs or where a high-frequency current is present. A spark is a small amount of current jumping an air gap in response to the force of a relatively high voltage. The gasoline engine ignition system is a common source. Magneto breaker points and static charges collecting on the frame are other common sources which must be suppressed.

## 55. General Methods to Attain Proper Suppression

Essentially, suppression is attained by providing a low-resistance path to ground for stray high-frequency currents. The methods used to attain suppression include shielding the ignition and high-frequency wires, and grounding the frame with bonding straps.

## 56. Replacement of Suppression Components

(fig. 20)

### a. Shielded Ignition Leads.

- (1) Loosen the nut that holds one end of each ignition lead (2) to the spark plug; disconnect the leads from the spark plugs.

- (2) Loosen the nut (1) that holds each ignition lead to the magneto (3); remove the shielded ignition leads.

- (3) Position the ends of the new leads on the spark plugs and on magneto; tighten nuts to secure leads.

### b. Ground Strap.

- (1) Remove the nuts (5) that secure the ground strap (6) to the magneto (3) and to the engine gear cover; remove the ground strap.

- (2) Position the new ground strap on the magneto and on the engine gear cover; secure with two nuts.

## Section V. FUEL SYSTEM

## 57. Description and Function

a. *General.* The purpose of the fuel system is to store, convey, mix fuel with air, and then vaporize and introduce the mixture into the engine. Fuel is stored in the gasoline tank. It is filtered and flows through the fuel supply lines to the carburetor under the pressure of a fuel pump. The carburetor mixes the fuel with the proper proportions of air and at the same time breaks it into very fine spray particles. This atomized spray changes to vapor as it travels through the heated intake manifold to the combustion chamber.

b. *Fuel Pump.* The mechanical fuel pump (4, fig. 2) is used to pump fuel from the fuel tank to the carburetor. The fuel pump mounts on the cylinder block and is driven by an eccentric cam on the engine camshaft contacting the fuel pump rocker arm. Constant fuel pressure is maintained by an air dome and a pulsating diaphragm operated and controlled by linkage which adjusts itself to pressure demands.

c. *Carburetor.* The carburetor (3, fig. 2) is an updraft carburetor of the double venturi design. Two body castings are used. The fuel bowl hugs the center line of the carburetor and together with the duplex float makes it possible for this unit to maintain proper metering of the air and fuel to the engine, without flooding, when the vehicle is operated on extreme angles. It is a sealed and balanced carburetor in that all air for bowl chamber ventilation and idling must come through the air cleaner. Two venturis aid in the complete vaporization of fuel. The power jet and accelerating pump systems operated by engine vacuum are completely enclosed and protected from dirt.

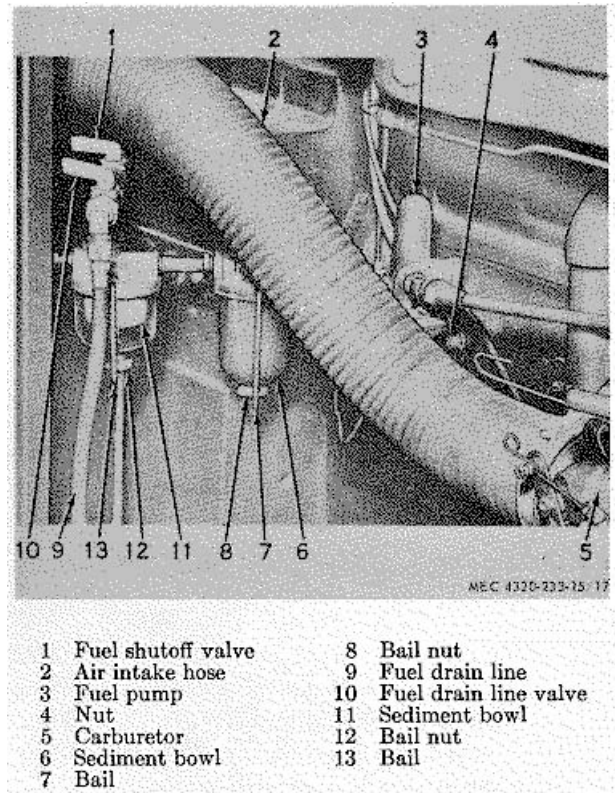

Figure 17. Fuel pump installation.

d. *Air Cleaner.* All engines, when operating, consume several thousand cubic feet of air per hour. Since dusty air is full of abrasive matters the engine will soon wear excessively if the air cleaner (2, fig. 4) does not remove the dust before entering the cylinders. Operating conditions determine the air cleaner

service periods. In extremely dusty operations, service once or twice daily; in dust-protected areas, service the air cleaner when changing oil.

e. *Governor*. The governor (1, fig. 2) uses round steel balls as the motivating force producer, instead of masses of weight. When the governor is driven at increasing speeds by the engine through the governor gear, the steel balls, moving outward, force the conical upper race, fork base, and fork and lever assembly toward a closed throttle position. An externally mounted spring imposes tension on the lever assembly toward the open throttle position. As the engine speed increases, the centrifugal force created by the balls increases until a balanced condition exists between the governor force and the spring force; the governing lever remains stationary, holding a constant engine speed. The desired engine speed is obtained by increasing or decreasing the governor spring tension.

f. *Fuel Primer Pump*. A fuel primer pump, mounted on the instrument panel (fig. 11), is provided to pump fuel into intake manifold for cold weather starting.

g. *Fuel Tank*. The fuel tank (6, fig. 2) is formed by metal sheets welded to the skids of the pumping unit. The tank is positioned approximately between the engine and centrifugal pump.

h. *Fuel Lines and Fittings*. Fuel lines and fittings carry fuel from the fuel tank to the fuel pump, and from the fuel pump to the carburetor. A priming line extends from the fuel pump to the primer pump, and a drain line is connected to the carburetor.

i. *Fuel Strainer*. A military approved fuel strainer is installed just ahead of the fuel pump. Fuel from the fuel tank is drawn through this strainer into the strainer section of the fuel pump.

#### **57.1. Fuel Strainer**

(fig. 17)

##### *a. Service.*

- (1) Close the fuel shutoff valve (1) Loosen the bail nut (12) and remove the sediment bowl (11), filter element, and gasket from the strainer.
- (2) Clean the bowl and filter element with an approved cleaning solvent; dry with clean compressed air.
- (3) Replace the gasket, and replace the filter element if clogged or distorted.
- (4) Install the filter element, gasket and bowl on the strainer; secure by tightening the bail nut.

- (5) Operate the engine and check for fuel leaks around the bowl.

##### *b. Removal.*

- (1) Disconnect the two fuel lines to the strainer.
- (2) Unscrew strainer from nipple at the fuel pump.

##### *c. Cleaning and Inspection.*

- (1) Clean all parts in an approved cleaning solvent; dry with clean, dry compressed air.
- (2) Inspect all parts for dents, cracked or damaged parts, stripped threads, or other defects. Replace damaged parts.

*d. Installation* Installation of the fuel strainer is the reverse of the removal procedure described in b above.

#### **58. Fuel Pump**

(fig. 17)

*a. Service.* Service the fuel pump sediment bowl in the same manner as the fuel strainer (para 57.1a).

##### *b. Removal.*

- (1) Remove the fuel strainer (para 57(1)b) and disconnect the two fuel lines at the fuel pump (3).
- (2) Remove the two mounting nuts (4) and lockwashers that secure the fuel pump to the engine block; remove the fuel pump and gasket.
- (3) Remove the fuel line fittings from the fuel pump.

##### *c. Cleaning and Inspection.*

- (1) Clean all parts in an approved cleaning solvent; dry with clean, dry compressed air.
- (2) Inspect all parts for dents, cracked or damaged parts, stripped threads, or other defects. Replace damaged parts.

*d. Installation* Installation of the fuel pump is the reverse of the removal procedure described in b. above.

#### **59. Carburetor**

(fig. 18)

##### *a. Adjustment.*

- (1) Adjust the carburetor with the engine at operating temperature and in a level position, and with about one-half tank of fuel.
- (2) The main jet adjusting screw (10) determines the amount of fuel which may be obtained for high-speed operation. To set this adjustment, open the throttle

about one-fourth open. Turn the adjusting screw clockwise, shutting off the fuel, until the engine speed decreases or begins to miss due to a lean mixture. Then turn the adjusting screw counterclockwise until the engine reaches its maximum speed and runs smoothly without missing.

- (3) The idle mixture adjusting screw (6) controls the amount of air admitted to the idling system, which functions only at low speeds. Turning the screw clockwise cuts off the air, making the mixture richer; turning the screw counterclockwise admits more air making the mixture leaner. Set the idle mixture adjusting screw for the smoothest running of the engine. If a vacuum gage is attached to the manifold, set the adjusting screw for the highest manifold vacuum. Adjust

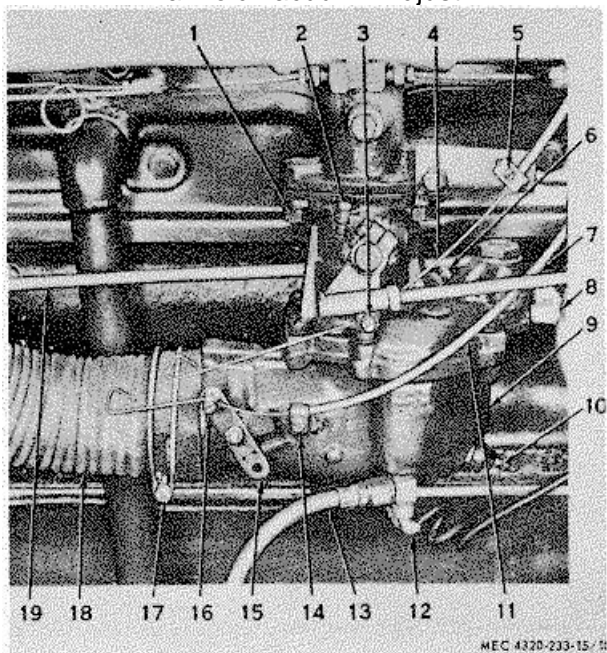

1 Nut	10 Main jet adjusting screw
2 Idle adjusting screw	11 Choke cable
3 Throttle cable adjusting screw	12 Carburetor drain cock
4 Throttle cable	13 Carburetor drain line
5 Throttle cable anchor clip	14 Choke cable anchor clip
6 Idle mixture adjusting screw	15 Choke lever
7 Governor linkage	16 Choke cable adjusting screw
8 Elbow	17 Hose clamp
9 Carburetor body	18 Air intake hose
	19 Fuel line

**Figure 18. Carburetor installation.**

the idle adjusting screw for 400 to 600 rpm idle operation.

**b. Removal.**

- (1) Open the carburetor drain cock (12) and drain the carburetor.
- (2) Loosen the hose clamp (17) that secures the air intake hose (18) to the carburetor body (9); remove the hose from the carburetor body.
- (3) Disconnect the governor linkage (7) from the carburetor.
- (4) Loosen the throttle cable adjusting screw (3) and throttle cable anchor clip (5); remove the throttle cable (4) from the carburetor.
- (5) Loosen the choke cable adjusting screw (16) and the choke cable anchor clip (14); remove the choke cable (11) from the carburetor.
- (6) Disconnect the fuel line (19) from the elbow (8) on the carburetor. Remove the elbow.
- (7) Remove the two mounting nuts (1) and lock washers that secure the carburetor to the manifold; remove the carburetor and gasket.

**c. Cleaning and Inspection.**

- (1) Clean the outside of the carburetor with a cloth dampened with cleaning solvent; wipe dry. Clean all metal parts in an approved cleaning solvent; dry with clean, dry compressed air. Clean the hose with a damp cloth.
- (2) Inspect the carburetor for damage; replace if damaged. Inspect all other metal parts for cracks, dents, or other damage; replace if damaged. Inspect the hose for cracks, wear, or deterioration; replace if damaged.

**d. Installation.** Installation of the carburetor is the reverse of the removal procedure described in b above. Observe the following special instructions:

- (1) When installing the choke cable (11), position the choke lever (15) so that the choke is in the open position, position the choke control knob about 1/16 inch from the full-in position, and tighten the choke cable adjusting screw (16).
- (2) When installing the throttle cable (4), hold the throttle lever in the closed position, position the throttle control knob about 1/16 inch from the full-in position, and tighten the throttle cable adjusting screw (3).

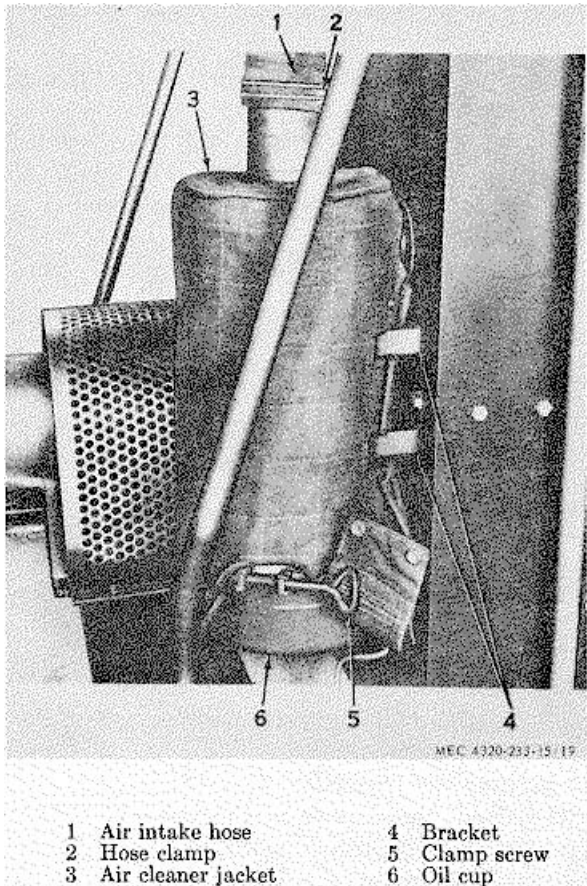

**Figure 19. Air cleaner.**

- (3) Adjust the carburetor (above).
- (4) Check governor adjustment (para 61).

#### **60. Air Cleaner**

(fig. 19)

##### *a. Service.*

- (1) Unsnap the air cleaner jacket (3) near the clamp screw (5).
- (2) Loosen the clamp screw and remove the oil cup (6) from the air cleaner.
- (3) Empty the dirty oil from the oil cup. Clean the cup in an approved cleaning solvent; dry with clean, dry compressed air.
- (4) Fill the oil cup to the level line with oil of the same type and viscosity used in the engine.
- (5) Position the oil cup (6) on the air cleaner; Secure by tightening the clamp screw (5).
- (6) Pull the air cleaner jacket (3) around the oil cup and clamp screw; secure with snaps.

##### *b. Removal.*

- (1) Remove the air cleaner jacket (3).

- (2) Remove the hose clamp (2) that secures the air intake hose (1) to the air cleaner; remove the hose from the air cleaner.
- (3) Remove the four bolts, lockwashers, and nuts that secure the air cleaner brackets (4) to the dash; remove the air cleaner.

##### *c. Cleaning and inspected.*

- (1) Clean the outside of the air cleaner with a cloth Dampened with cleaning solvent. Service the air cleaner as directed in above.
- (2) Inspect the air cleaner for damage; replace if damaged.

*d. Installation.* Installation of the air cleaner is the reverse of the removal procedure described in b above.

#### **61. Governor**

(fig. 20)

##### *a. Adjustment.*

- (1) Adjust the governor with the engine at operating temperature and the carburetor properly adjusted.
- (2) Back out the surge adjusting screw (9) so it will have no effect on engine operation.
- (3) With the engine running, adjust the high speed adjusting screw (11) for an engine speed of approximately 1,950 rpm.
- (4) Load the engine. Adjust the high speed adjusting screw (11) for an engine speed of 1,800 rpm.
- (5) Release the load and not the speed of the engine.
- (6) Again apply the load and observe the drop in the engine speed before the governor opens the throttle to compensate for the load.
- (7) The range of governor action is indicated by the difference between the speed under load and the speed under no load. This can be varied with the sensitivity adjusting nuts (12). Normally it is not necessary to adjust the sensitivity, which is set at the factory. However, if regulation is too broad, increase the tension of the governor spring with the sensitivity adjusting nuts. If regulation is too close, decrease the tension on the spring.
- (8) Screw in the surge adjusting screw (9) until the engine idles smoothly. Lock the surge adjusting screw locknut and high speed screw locknut.

TAGO 6358-A

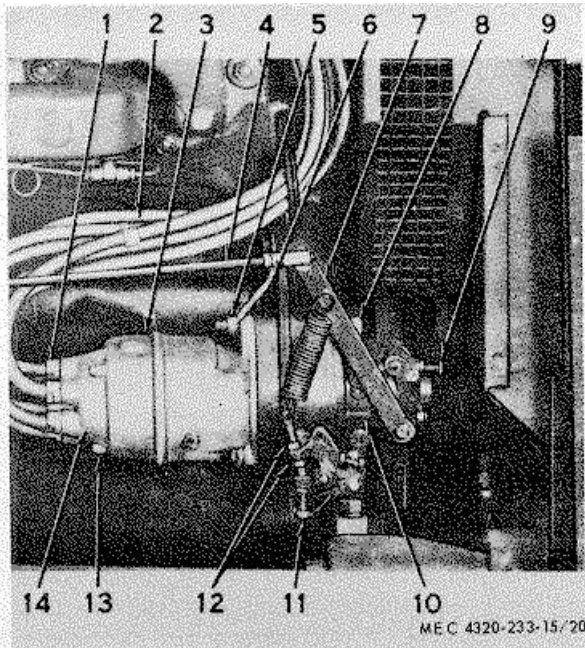

- |                           |                               |
|---------------------------|-------------------------------|
| 1 Nut                     | 9 Surge adjusting screw       |
| 2 Shielded ignition leads | 10 Governor housing           |
| 3 Magneto                 | 11 High speed adjusting screw |
| 4 Governor linkage        | 12 Sensitivity adjusting nut  |
| 5 Nut                     | 13 Cover mounting screw       |
| 6 Ground strap            | 14 Cover                      |
| 7 Governor lever arm      |                               |
| 8 Thru bolt               |                               |

**Figure 30. Governor and magneto installation.**

**b. Removal.**

- (1) Disconnect the governor linkage (4) from the governor lever arm (7).
- (2) Remove the bolt (8), lockwashers, nut (5), and screw that secure the governor to the engine gear cover; remove the governor and gasket.

**c. Cleaning and Inspection.**

- (1) Clean the outside of the governor with a cloth dampened with cleaning solvent; wipe dry. Take care so that solvent does not enter the governor.
- (2) Inspect the governor for dents, cracks, broken or worn gear teeth, broken or deformed linkage, stripped threads, or other damage. Replace or refer to higher authority if damaged.

**d. Installation.**

- (1) Remove the screw that holds the lower end of the magneto to the gear cover; remove the magneto but do not disconnect the leads to the magneto.

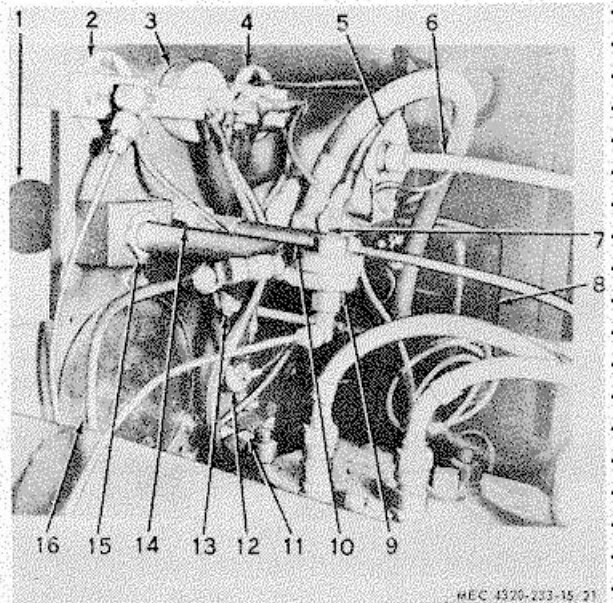

- |   |                             |
|---|-----------------------------|
| 1 Primer pump knob                                | 7 Battery disconnect switch |
| 2 Engine oil pressure gage and safety switch      | 8 Generator regulator       |
| 3 Ammeter   | 9 Fuel primer pump          |
| 4 Engine water temperature gage and safety switch | 10 Throttle                 |
| 5 Tachometer and hourmeter                        | 11 Starter button           |
| 6 Tachometer drive cable                          | 12 Magneto switch           |
|   | 13 Choke control            |
|   | 14 Nut                      |
|   | 15 Nut                      |
|   | 16 Discharge pressure gage  |

**Figure 21. Instrument panel, rear view.**

- (2) Position the governor and gasket on the engine cover, sighting through the magneto mounting port to make sure that the marked gear tooth of the governor engages the two marked teeth of the camshaft timing gear.

**Caution**

**Failure to mesh the marked tooth of the governor with the two marked teeth of the camshaft timing gear will disrupt timing of the engine, since the magneto and governor are driven by a common gear on the governor. This will prevent engine operation.**

- (3) Secure the governor to the gear cover at the bottom with a screw and lockwasher. Secure the bottom of the magneto to the gear cover with a screw and lockwasher after timing the magneto as directed in paragraph 70c.
- (4) Secure the tops of the governor and magneto to the gear cover with the long thru bolt (8) and nut (5), installing the ground strap (6) under the nut.

- (5) Adjust the governor as described in a above.

**62. Fuel Primer Pump**  
(fig. 21)

*a. Removal.*

- (1) Disconnect the two fuel lines from the fuel primer pump (9).
- (2) Remove the knob (1) from the pump.
- (3) Remove the nut (15) that secures the pump to the bracket on the instrument panel; remove the pump.

*b. Cleaning and Inspection.*

- (1) Clean the outside of the fuel primer pump with a cloth dampened in cleaning solvent; wipe dry. Do not allow solvent to enter the fuel primer pump.
- (2) Inspect the fuel primer pump for cracks, breaks, or other damage; replace if damaged.

*c. Installation* Installation of the fuel primer pump is the reverse of the removal procedure described in a above.

**63. Fuel Tank Lines, and Fittings**  
(fig. 22)

*a. Draining Fuel Tank* Drain the fuel tank (1) by loosening the cap and removing the pipe plug (29).

*b. Removal.* Fuel lines and fittings are illustrated in figure 22. Remove the fuel lines by loosening the coupling nuts at each end of the line and removing any attaching hardware.

*c. Cleaning and Inspection*

- (1) Clean the fuel lines and fittings by immersing them in an approved solvent. Blow through with clean, dry compressed air.
- (2) Inspect the fuel lines and fittings for cracks, dents, restrictions, clogging, or damage. Replace defective parts.

*d. Fabrication* Fabricate replacement fuel lines with a standard copper tubing flaring tool. Make a new line the same length as the line being replaced and bend the new line to the shape of the old line.

*e. Installation* Installation of the fuel lines and fittings is the reverse of the removal procedure described in subparagraph b above. After installation, test the new lines for leaks.

TAGO 6358-A

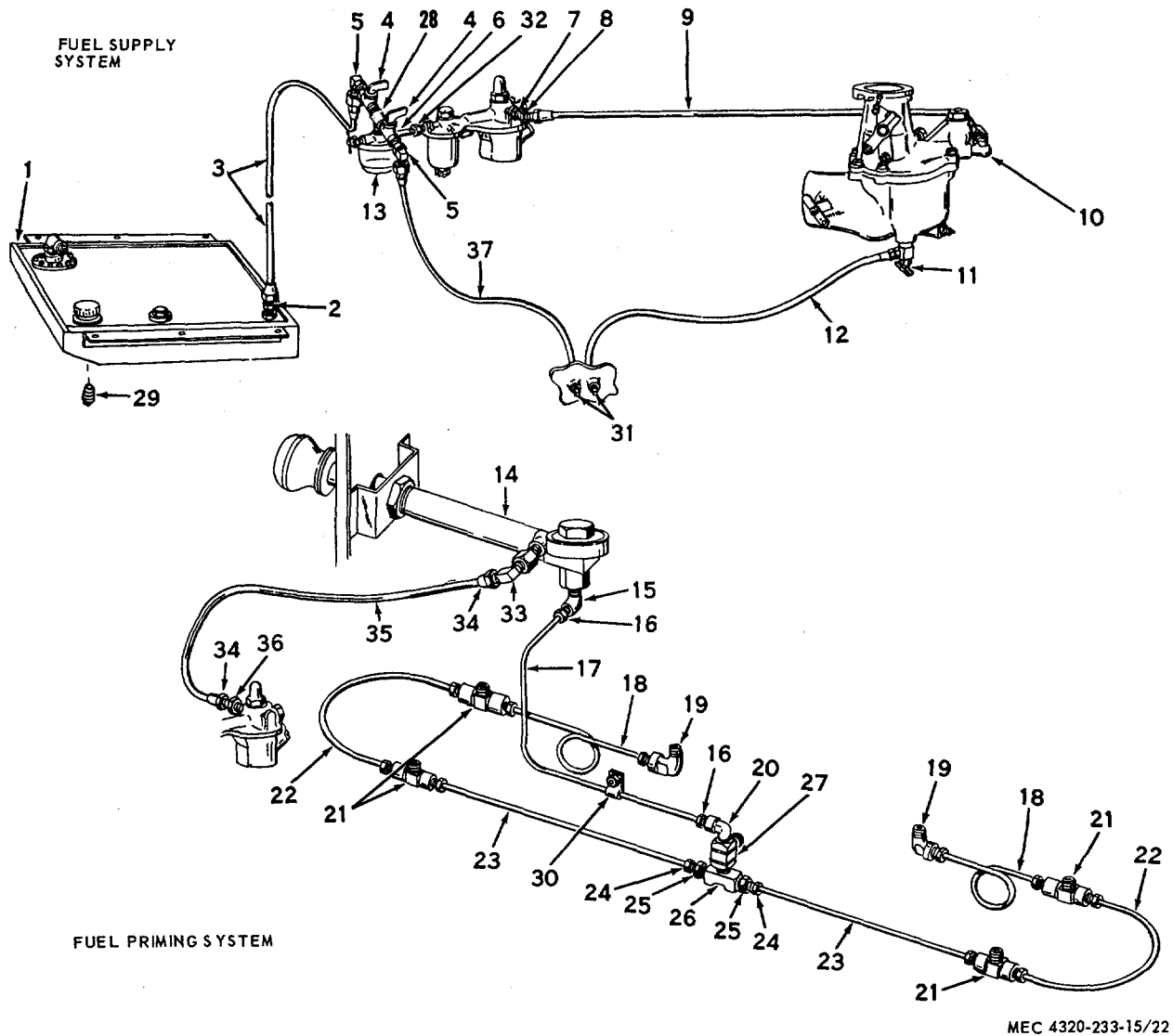

MEC 4320-233-15/22

- |                          |                      |                    |
|--------------------------|----------------------|--------------------|
| 1 Fuel tank              | 14 Fuel priming pump | 26 Tee             |
| 2 Adapter                | 15 Elbow             | 27 Tee             |
| 3 Fuel supply tube       | 16 Tube nut          | 28 Tee             |
| 4 Fuel shutoff cock      | 17 Tube              | 29 Pipe plug       |
| 5 Elbow                  | 18 Tube              | 30 Clip            |
| 6 Nipple                 | 19 Primer elbow      | 31 Plug            |
| 7 Reducer bushing        | 20 Elbow             | 32 Reducer bushing |
| 8 Elbow                  | 21 Primer tee        | 33 Elbow           |
| 9 Hose                   | 22 Tube              | 34 Tube nut        |
| 10 Elbow                 | 23 Tube              | 35 Tube            |
| 11 Carburetor drain cock | 24 Tube nut          | 36 Connector       |
| 12 Hose                  | 25 Connector         | 37 Hose            |
| 13 Filter                |                      |                    |

Figure 22. Fuel tank, lines, and fittings.



## Section VI. ENGINE SYSTEM

### 64. Description and Function

*a Batteries* The unit is powered by two 12olt storage batteries connected in series and contained in a battery box (7, fig. 3 Located at the rear of the pumping unit. Quickrelease connectors are provided on the battery cables.

*b Generator* The generator (1, fig. 1) is rated at 24 volts, 18 amperes do (direct current). It is driven by a V-belt from the water pump pulley. Periodic checks of the generator prevent unnecessary repairs. The length of time between inspections varies according to the generator load and operating conditions. Under normal usage, inspect the generator every 500 hours of operation.

*c Generator Regulator* The generator regulator is mounted on the inside of the flywheel end of the engine housing. It includes a cutout relay, voltage regulator, and current regulator. They are mounted on one base and enclosed by one cover.

*d Starting Motor* The 24-volt starting motor (4, fig. 1) is located on the side of the engine at the lower rear. When in operation, it engages the ring gear on the flywheel to rotate the engine crankshaft.

*e Magneto* The magneto (2, fig. 2) is of the rotating magnet, high tension type, designed to provide radio shielded ignition. It has an impulse coupling which assists starting by automatically retarding the ignition spark during the starting operation. During the starting cycle, the impulse coupling prevents the rotor of the magneto from turning until the engine piston is at top dead center. At this instant, the rotor is snapped forward at a very high speed, producing an intense spark which would be impossible at cranking speeds. The impulse coupling automatically advances the spark to the desired setting while the engine is running.

### 65. Batteries (fig. 23)

*a Service.* Add distilled water to the batteries (3) as necessary. Clean the battery posts and cable terminals with a wire brush and a solution of baking soda. Coat the posts and terminals with grease after cleaning.

*b Testing.* Check the specific gravity of each cell with a battery hydrometer. The specific gravity of each cell must be at least 1.250.

#### *c Replacement*

- (1) Remove the wingnuts that secure the battery box cover to the battery box (6); remove the cover.

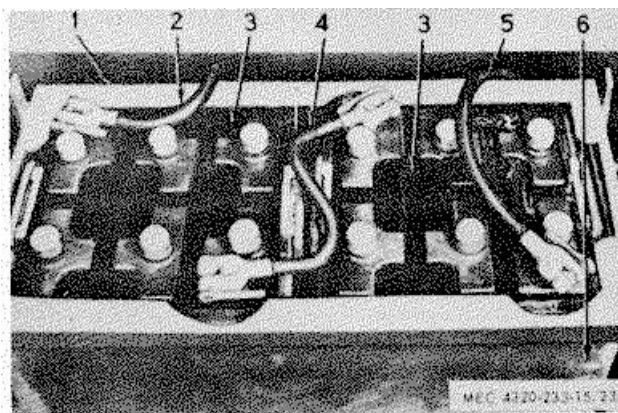

- |                 |                                 |
|-----------------|---------------------------------|
| 1 Top frame     | 4 Battery interconnecting cable |
| 2 Battery cable | 5 Battery cable                 |
| 3 Battery       | 6 Battery box                   |

**Figure 23. Batteries installed.**

- (2) Disconnect the cables (2, 4, and 5) from the batteries (3).
- (3) Remove the battery box top frame (1) from the batteries; remove the batteries.
- (4) Position new batteries (3) in the battery box (6) and position the battery box top frame (1) on the batteries.
- (5) Connect the cables (2, 4, and 5) to each battery.
- (6) If the batteries are the drycharge type, add electrolyte. Fill to the level indicated by the battery manufacturer.
- (7) Position the cover on the battery box; secure with wingnuts.

### 66. Generator

#### *a Output Testing*

- (1) Connect the generator regulator ~~an~~ generator as shown in figure 24. Run the engine to allow temperature of the generator to reach 77° F.
- (2) Use a hand tachometer to check generator speed. With the generator speed at 1,425 rpm, generator output must be 4 amperes at 28.5 volts.
- (3) With the generator speed at 2,850 rpm, generator output must be 18 amperes at 28.5 volts.

#### *b Removal*

- (1) Loosen the generator mounting bolts (8, fig. 25) and the belt adjusting screw (3).

Push the generator (7) toward the engine and slip the generator—fan belt (2) off the generator pulley.

- (2) Remove the electrical connector (6) from the generator.
- (3) Remove the belt adjusting screw and the generator mounting bolts; remove the generator.
- (4) Remove the nut and lockwasher that secure the generator drive pulley (11) to the armature shaft; pull the generator drive pulley, baffle (10), fan (9), and key from the armature shaft.

*c Cleaning and Inspection.*

- (1) Clean the outside of the generator with a cloth dampened with cleaning solvent; wipe dry. Take care that no cleaning solvent enters the generator or comes in contact with wires or electrical parts. Clean all other metal parts in cleaning solvent. Dry with clean, dry compressed air.
- (2) Inspect the generator for damage; replace a damaged generator or refer to the proper authority. Inspect all other parts for cracks, breaks, dents, stripped threads, or other damage; replace damaged parts.

*d Installation* Installation of the generator is the reverse of the removal procedure described in b above. Observe the following special instructions:

- (1) Do not fully tighten the generator mounting bolts (8) and belt adjusting screw (3) until after the generator—fan belt has been adjusted.
- (2) Adjust the generator—fan belt (pare 67a).

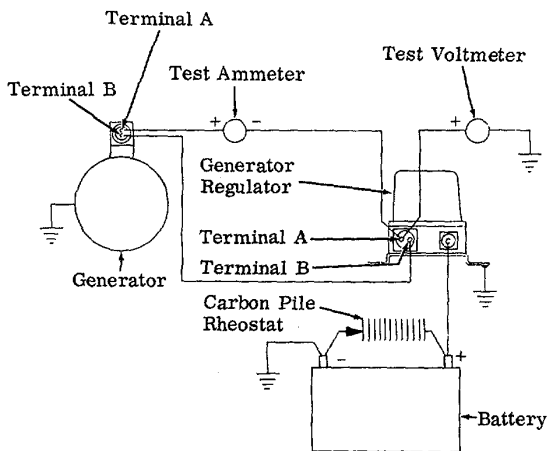

**Figure 24. Generator test circuit.**

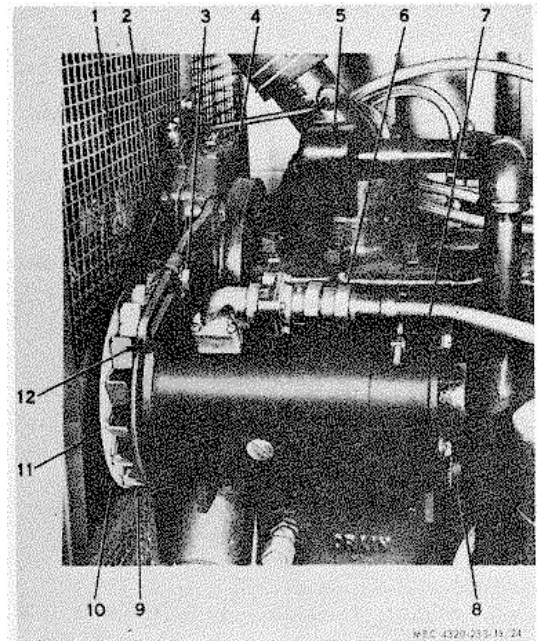

- |                        |                              |
|------------------------|------------------------------|
| 1 Fan guard            | 8 Mounting bolt              |
| 2 Generator—fan belt   | 9 Generator fan              |
| 3 Belt adjusting screw | 10 Baffle                    |
| 4 Water pump           | 11 Generator drive pulley    |
| 5 Thermostat housing   | 12 Generator adjusting strap |
| 6 Connector            |                              |
| 7 Generator            |                              |

**Figure 25. Generator and water pump installation.**

**67. Generator—Fan Belt (fig. 25)**

*a Adjustment*

- (1) Loosen the generator mounting bolts (8) and belt adjusting screw (3).
- (2) Pull the generator away from the engine block until the generator—fan belt (2) deflects ~ inch when depressed by hand midway between the generator and water pump pulleys.
- (3) Tighten the belt adjusting screw (3) and the generator mounting bolts (8).

*b Replacement*

- (1) Remove the screws and lockwashers that secure the fan guard (1) to the radiator shroud; remove the fan guard.

- (2) Loosen the generator mounting bolts (8) and the belt adjusting screw (3). Push the generator toward the engine block.
- (3) Slip the belt off the pulleys and remove from the engine.
- (4) Install a new generator-fan belt on the pulleys.
- (5) Adjust the belt tension as directed in a above.
- (6) Position the fan guard (1) on the radiator shroud; secure with the fan guard mounting screws and lockwashers.

## 68. Generator Regulator

### a. Testing and Adjustment.

- (1) Remove the seal and six machine screws with assembled washers that secure the cover of the generator regulator to the base; remove the cover.

#### Warning

: Disconnect the batteries before measuring and adjusting the air gap (point) openings.

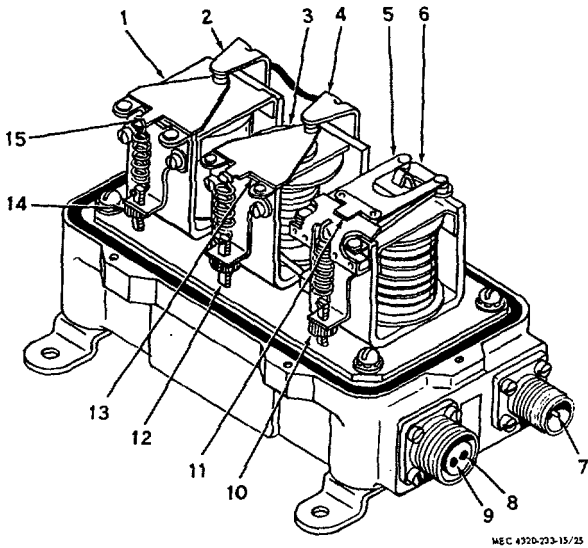

- |  |                                    |
|--|------------------------------------|
| 1 Current regulator unit               | 9 Terminal A                       |
| 2 Current regulator adjustable contact | 10 Circuit breaker adjusting nut   |
| 3 Voltage regulator unit               | 11 Armature                        |
| 4 Voltage regulator adjustable contact | 12 Voltage regulator adjusting nut |
| 5 Circuit breaker unit                 | 13 Armature                        |
| 6 Circuit breaker adjustable contact   | 14 Current regulator adjusting nut |
| 7 Battery terminal                     | 15 Armature                        |
| 8 Terminal B                           |                                    |

Figure 26. Generator regulator with cover removed, showing adjusting points.

- (2) Check the armature core gap of the circuit breaker unit (5, fig. 25) with a feeler gage

(see Note below). With the circuit breaker points held just closed, the armature core gap must be 0.066 to 0.070 inch. If necessary, loosen the screws that secure the circuit breaker adjustable contact (6) to the bracket. Adjust the position of the contact until it is within the required limits.

#### Note

The core of each of the three units of the voltage regulator consists of a brass armature stop pin surrounded by an iron core. The brass pin extends above the iron core. When checking armature core gap, measure with the side feeler gage against the side of the brass pin—not on the brass pin. Gap must be measured from the iron core to the armature only.

- (3) Check the armature core gap of the voltage regulator unit (3) and current regulator unit (1). With the contacts closed, insert a 0.056 inch feeler gage between the core and armature (see Note above) and attempt to open the contacts. The contacts should not open. Insert a 0.053-inch feeler gage between the armature and core and attempt to open the contacts. The contacts should just open. If necessary, loosen the screws that secure the adjustable contacts to the bracket; adjust the position of the contact so that the correct gap exists.
- (4) To check the circuit breaker opening and closing, connect the generator regulator and generator in a circuit as shown in figure 27. With the field rheostat set at maximum resistance, start the engine and operate it at 1,800 rpm. Adjust the field rheostat while watching the voltmeter. Check the closing voltage of the circuit breaker contacts. It must be 25.7 to 26.7 volts as indicated on the voltmeter.
- (5) Operate the field rheostat so that the generator is charging at 15 amperes. Operate at this output for 5 minutes minimum. Operate the field rheostat to decrease output while watching the meters to determine the opening point of the circuit breaker. It should open between 4.0 and 6.8 amperes. If the circuit breaker fails to open or close within the required range, adjust the setting of the circuit breaker adjusting nut (10, fig. 26) to get the required range.

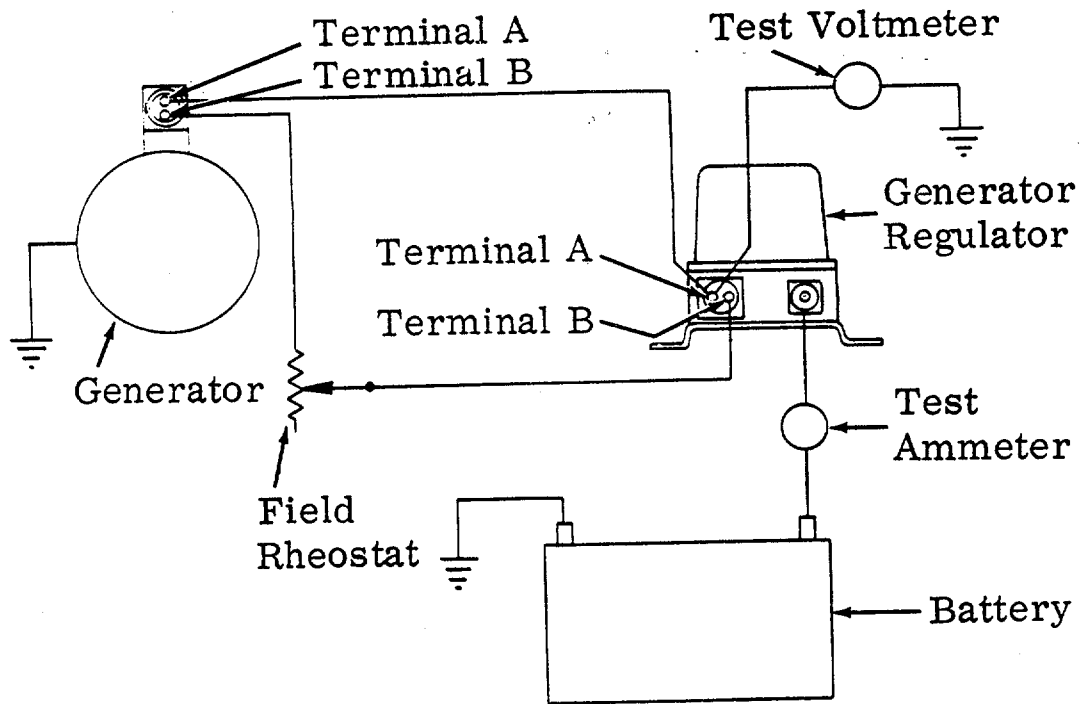

**CIRCUIT BREAKER OPENING AND CLOSING TEST**

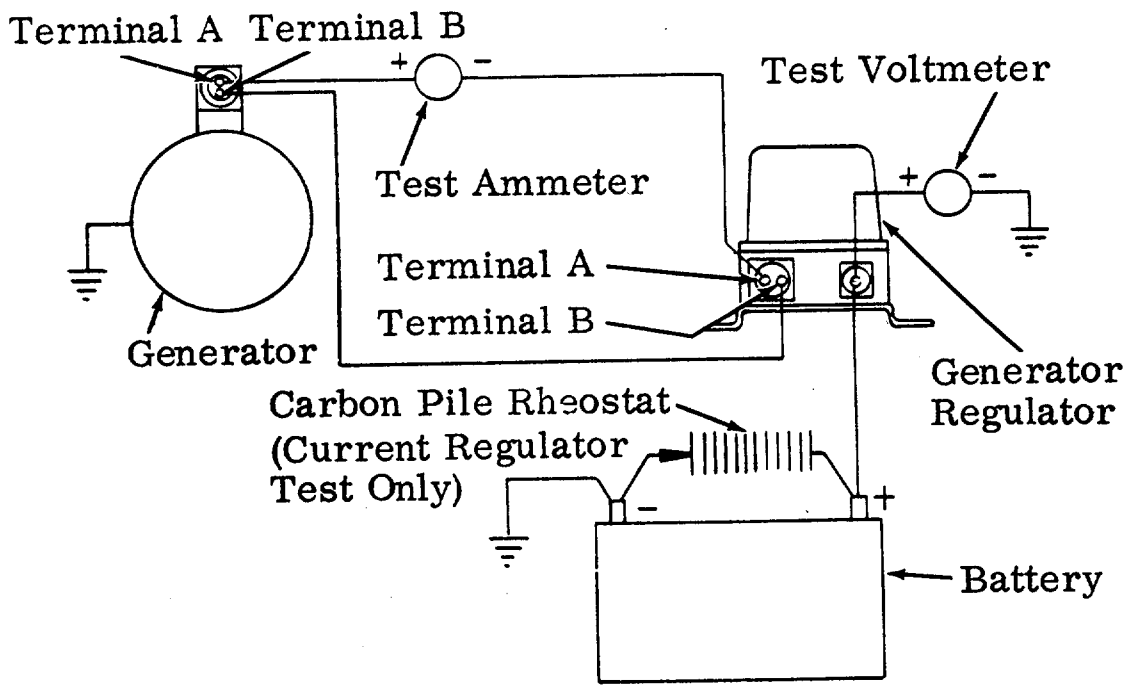

**VOLTAGE REGULATOR AND CURRENT REGULATOR TEST**

MEC 4320-233-15/26

Figure 27. Generator regulator test setup.

(6) To check the voltage regulator operating voltage, connect the generator regulator and generator in a circuit as shown in figure 27. Operate the engine at 1,425 rpm. Operating voltage must be as follows:

Temperature F.	50 °	80°	110°	140°
Operating voltage (~5 volts)	28.0	27.85	27.6	27.3

(7) If the voltage regulator fails to operate within the required range, adjust the setting of the voltage regulator adjusting nut (12, fig. 26) until the required range is attained.

(8) With the generator regulator connected as shown in figure 26, using the carbon pile rheostat, check the operating amperage of the current regulator. It should operate at 17 to 19 amperes. If it fails to operate within the required range, adjust the setting of the current regulator adjusting nut (14, fig. 26) until the required range is attained.

(9) If the adjustments cannot be made, replace the generator regulator.

#### b Replacement

- (1) Disconnect the two electrical connectors from the generator regulator (8, fig. 21).
- (2) Remove the four screws and lockwashers that secure the generator regulator to the flywheel end of the engine housing; remove the generator regulator.
- (3) Position a replacement regulator on the back of the instrument panel; secure with the four screws and lockwashers.
- (4) Secure the two electrical connectors to the generator regulator.

### 69. Starting Motor

#### a Removal fig. 28).

- (1) Tag and remove leads from the starter solenoid.
- (2) Remove the three mounting bolts (3) and lockwashers that secure the starting motor (4) to the flywheel housing; remove the assembled starting motor and solenoid (1).

#### b. . Cleaning and Inspection.

- (1) Clean the outside of the starting motor with a cloth dampened with cleaning solvent; wipe dry. Take care that solvent

motor 2 Solenoid mounting bolt 5 Screw 3 Starting motor mounting bolt does not enter the starting motor or contact the electrical parts.

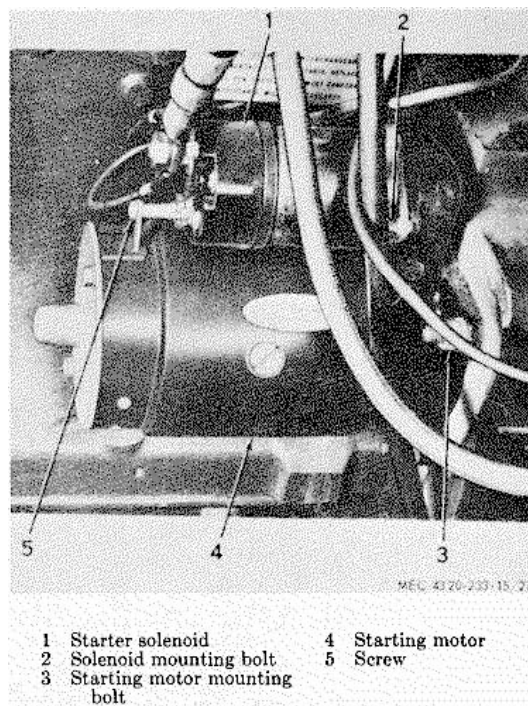

**Figure 88. Starting motor and solenoid installation.**

- (2) Inspect the assembled starting motor and solenoid for cracks, breaks, broken or worn gear teeth, or other damage. Replace or refer to higher authority if damaged.

*c Installation.* Installation of the starting motor is the reverse of the removal procedure described in a above.

#### d Testing

- (1) Remove the starting motor and solenoid as directed in a above.
- (2) Connect the starting motor and solenoid in the test circuit shown in figure 28. Adjust the starting motor to 3,650 rpm by adjusting the variable resistance. With the starting motor operating at 3,650 rpm, current draw must not exceed 72.5 amperes and voltage draw must not exceed 23.5 volts. If current or voltage draw is not within limit or the motor will not turn at 3,650 rpm, replace the motor or the solenoid.
- (3) Install the starting motor and solenoid as directed in c above.

e. *Starter Solenoid Replacement (fig. 28).*

- (1) Remove the starting motor and solenoid assembly as directed in a above.
- (2) Remove the screw (5) that secures the lead from the starting motor to the solenoid.
- (3) Remove the two solenoid mounting bolts (2) and lockwashers; remove the solenoid from the starting motor. The solenoid plunger will remain attached to the shift lever.
- (4) Remove the pin that secures the solenoid plunger to the shift lever; remove the plunger.
- (5) Position the replacement solenoid plunger on the shift lever; secure with the plunger pin.
- (6) Slide replacement solenoid (1) over plunger and into position on starting motor housing; secure with two solenoid mounting bolts and lockwashers.
- (7) Connect lead from starting motor to solenoid.
- (8) Install the starting motor and solenoid assembly as directed in c above.

**70 Magneto**

a. *Removal (fig. 20).*

- (1) Tag the shielded ignition leads (2). Loosen the nuts (1) and disconnect the leads from the magneto.
- (2) Remove the two nuts (5) and lockwashers that secure the magneto to the engine front end cover; remove the magneto.

b. *Cleaning and Inspection.*

- (1) Clean the outside of the magneto with a cloth dampened with cleaning solvent; wipe dry. Take care that solvent does not enter the magneto or contact the electrical parts.
- (2) Inspect the magneto for cracks, breaks, worn or broken gear teeth, or other damage. Remove and inspect the distributor head for carbon runners, damage, or evidence of failure. Replace or refer to higher authority if damaged.

c. *Timing and Installation.*

- (1) Remove the rear spark plug. Put a thumb over the spark plug hole and crank the engine by hand until air is ejected from the cylinder.
- (2) Set the piston on top dead center by slowly cranking until the DC mark on the flywheel TAGO 3S8-A

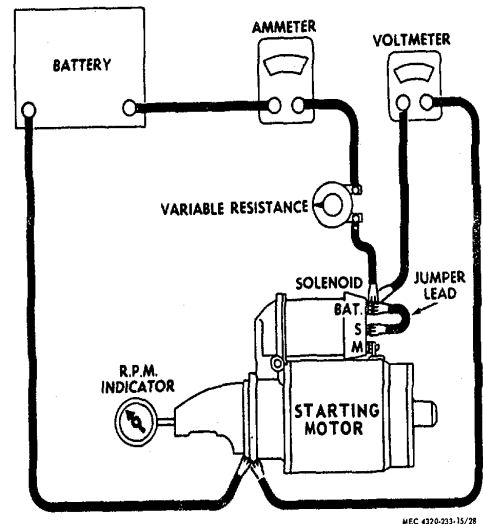

**Figure 29. Starting motor and solenoid testing circuits.**

lines up with the pointer on the flywheel housing as shown in figure 30.

- (3) Place the magneto in a vise lined with soft cloths and turn the drive lugs of the impulse coupling until the lead to plug No. 6 fires.
- (4) Turn the magneto drive lugs of the impulse coupling counterclockwise about one-quarter turn so the drive lugs will mesh with the driving slots of the governor drive gear.
- (5) Position the magneto on the engine and tighten the mounting nuts moderately. Connect the shielded ignition leads (2, fig. 20) and spark plug ground strap (6).
- (6) Start and idle the engine at 400 to 500 rpm. Use a timing light connected to the rear plug to see if timing is directly at the DC mark as shown in figure 30.
- (7) If not, rotate the magneto assembly until timing is correct. The lower magneto mounting hole is slotted. Tighten the magneto mounting nuts when proper timing is achieved.

d. *Magneto Point Adjustment.*

- (1) Remove the four cover mounting screws (13, fig. 20) and lockwashers; remove the cover (14) from the magneto.
- (2) Crank the engine until the points are forced apart as far as possible by the cam.

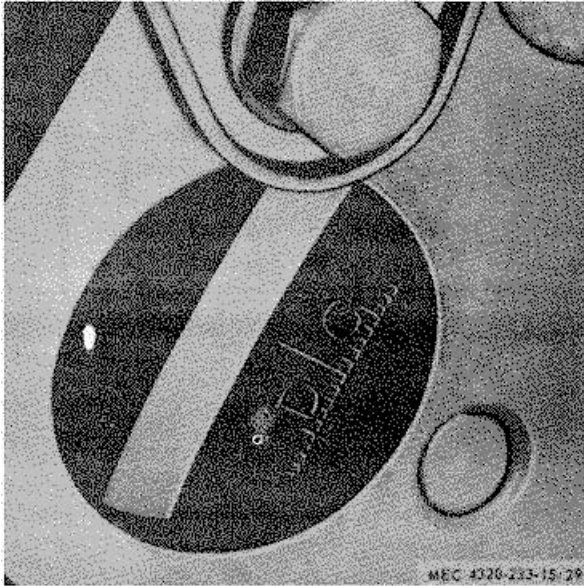

**Figure 30. Timing pointer aligned with DC mark on flywheel.**

- (3) Loosen the point mounting screw and adjust the points to 0.008 inch to 0.012 inch clearance as shown in figure 31. Tighten the point mounting screw.
- (4) Position the cover (14, fig. 20) on the magneto; secure with the four cover mounting screws (13) and lockwashers.
- (5) Time the magneto as directed in c(6) and (7) above.

## 71. Spark Plugs and Ignition leads

### a. Spark Plug Service and Replacement.

- (1) Loosen the nuts that secure the shielded ignition leads to the spark plugs; disconnect the leads.

## 72. Description and Function

The coolant system prevents the temperature in the engine combustion chamber, which may reach as high as 4,000° F., from damaging the engine. Maintaining coolant system efficiency is important. Engine temperatures must be brought up to and maintained within a satisfactory range for efficient operation; overheating must be avoided.

## 73. Coolant Line and Hose Replacement

a. Drain the coolant to a level below the line or hose to be replaced.

b Coolant piping is shown in figure 32. Remove the hoses by loosening the hose clamps and sliding 40

**TAGO 6358-A**

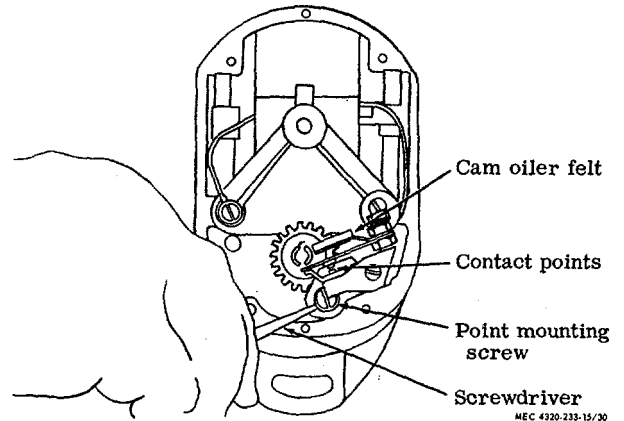

**Figure 31. Magneto point adjustment.**

- (2) Clean around each spark plug with a clean cloth and compressed air. Remove the spark plugs with a deepwell socket wrench or a spark plug wrench.
- (3) Clean the plugs with a spark plug sand blaster. Set the plug gap at 0.025 inch.
- (4) Inspect the spark plugs for cracked or eroded porcelain, burned electrodes, damaged threads, or other defects. Test the spark plugs on a spark plug tester. Replace defective spark plugs.
- (5) Install spark plugs in the cylinder head.
- (6) Connect ignition leads.

b Shielded Ignition Lead Replacement. Disconnect the ignition leads (2, fig. 20), from the spark plug and magneto, one at a time. Install replacement leads as old leads are removed.

## Section VII. COOLANT SYSTEM.

the hose off the part to which it is attached. Disconnect pipes with a pipe wrench.

c Slide replacement hoses over the part to which they connect; secure by tightening the hose clamps. Apply pipe joint sealer to the threads of metal water lines before installation.

d Refill the coolant system with coolant.

## 74. Water Pump.

### a Removal

(1) Drain the coolant system to a level below the water pump (4, fig. 25).

- (2) Disconnect the coolant hose (14, fig. 32) from the water pump. Remove the tube (18) and adapter (19) from the water pump.
- (3) Remove the generator-fan belt as directed in paragraph 67b.
- (4) Remove the four screws and lockwashers that secure the fan to water pump shaft; remove fan.
- (5) Remove the screw that connects the generator adjusting strap (12, fig. 25) to the water pump; remove the strap.
- (6) Remove the two screws and lockwashers and the two nuts and lockwashers that secure the water pump to engine block; remove water pump and gasket.

**b. Cleaning and Inspection.**

- (1) Clean the outside of the water pump with a cloth dampened in cleaning solvent; wipe dry.
- (2) Inspect the water pump for cracks, breaks, stripped threads, or other damage. Replace or refer to higher authority if damaged. Inspect the gasket for damage; replace if damaged.

**c. Installation.** Installation of the water pump is the reverse of the removal procedure described in a above. Observe the following special instructions:

- (1) When installing the generator adjusting strap (12, fig. 25), do not fully tighten the screw until after the generator-fan belt has been adjusted.
- (2) Adjust the generator-fan belt (para 67a):
- (3) Refill the coolant system.

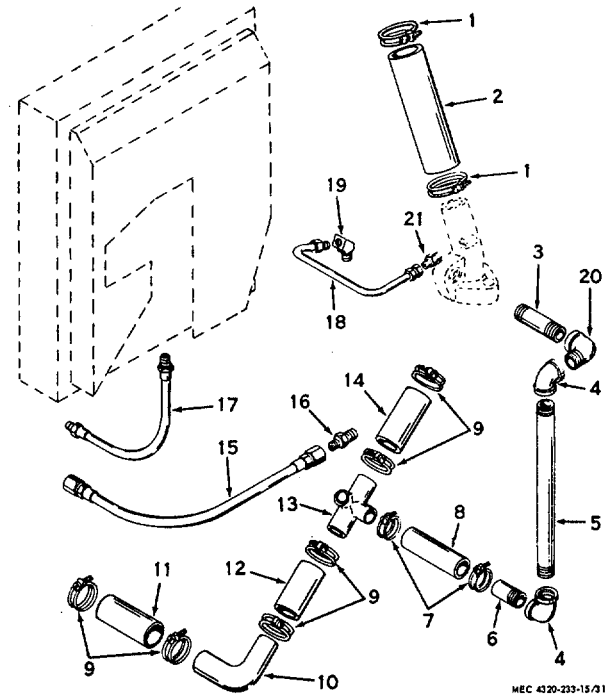

1 Hose clamp	12 Hose
2 Hose	13 Tee
3 Pipe nipple	14 Hose
4 Elbow	15 Hose assembly
5 Pipe nipple	16 Connector
6 Pipe nipple	17 Hose assembly
7 Hose clamp	18 Tube
8 Hose	19 Adapter
9 Hose clamp	20 Elbow
10 Elbow	21 Connector
11 Hose	

**Figure 32. Coolant piping, exploded view.**

**b. Testing.**

- (1) Suspend the thermostat in water as shown in figure 33.
- (2) Heat the water. If the thermostat valve does not open when the water is between 1500 and 1850 F., the thermostat is defective.

**c. Installation.** Installation of the thermostat is the reverse of the removal procedure described in a above. Observe the following special instructions:

- (1) Apply pipe joint sealer to the threads of the coolant bypass piping.
- (2) Refill the coolant system.

**75. Thermostat**

**a. Removal.**

- (1) Drain the coolant system to a level below cylinder head.
- (2) Loosen hose clamp (1, fig. 32) and remove radiator hose (2) from thermostat housing (5, fig. 25).
- (3) Disconnect the copper tube (18, fig. 32) from the thermostat housing.
- (4) Loosen the hose clamp (7) and remove the hose (8) from the inlet tee (13) and from the bypass piping. Using a pipe wrench, remove the coolant bypass piping (3 through 6) from the thermostat housing.
- (5) Remove the two nuts and lockwashers that secure the thermostat housing to the cylinder head; remove the thermostat housing, thermostat, and gasket.

**76. Radiator Service**

- a. The radiator or heat exchanger consists of a series of copper tubes through which the coolant water is circulated. In standard radiator design



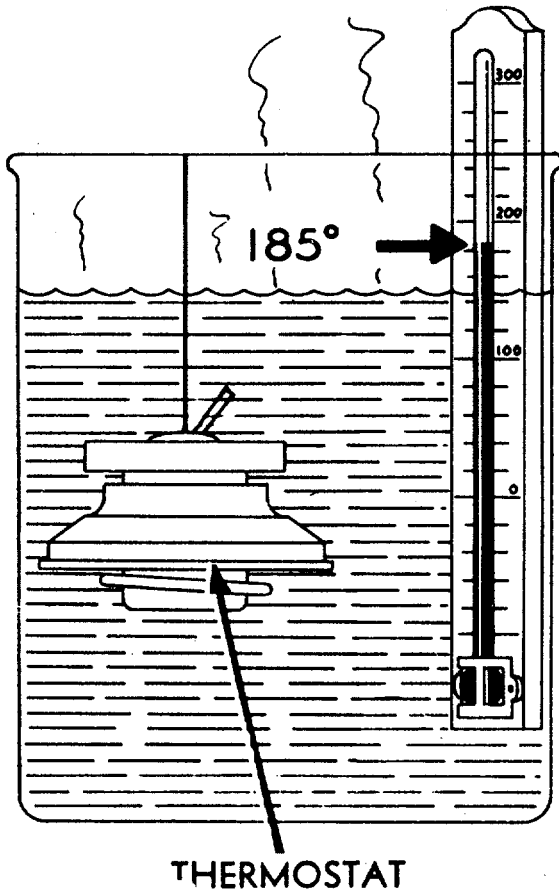

MEC 4320-233-15/32

Figure 33. Testing thermostat.

fins are connected to the copper tubes to give an extended surface through which heat can be dissipated. These tubes must be kept clean on the inside and the fins must be free of dirt on the outside so that maximum heat transfer can take place in the radiator.

- b. Blowing out between the fins of the radiator, using compressed air in a direction opposite to that of the fan circulated air, will serve to keep the cooling surfaces of the core free of dirt and other particles.
- c. Every 500 hours of operation, clean and flush the radiator and coolant system with clean water.
- d. Wherever possible, use only soft, clean water in the coolant system. Hard water will cause scale to form in the radiator and the engine water jackets and cause poor heat transfer. If the use of hard water cannot be avoided, use an approved water softener.

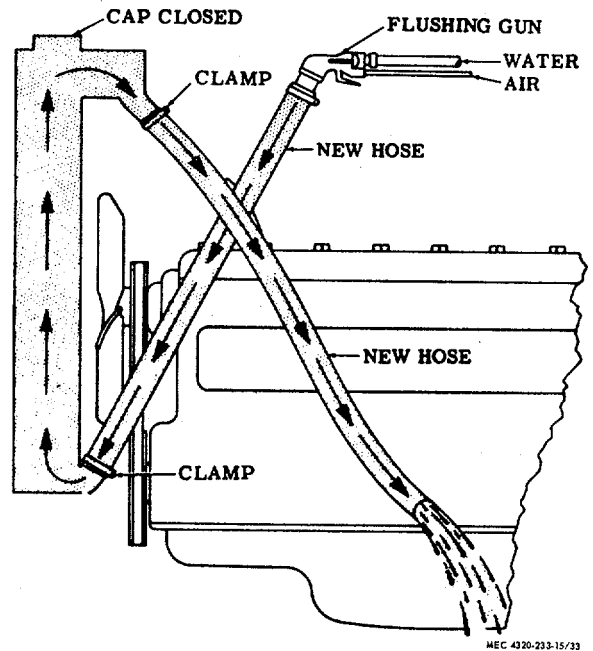

MEC 4320-233-15/33

Figure 84. Reverse flushing radiator.

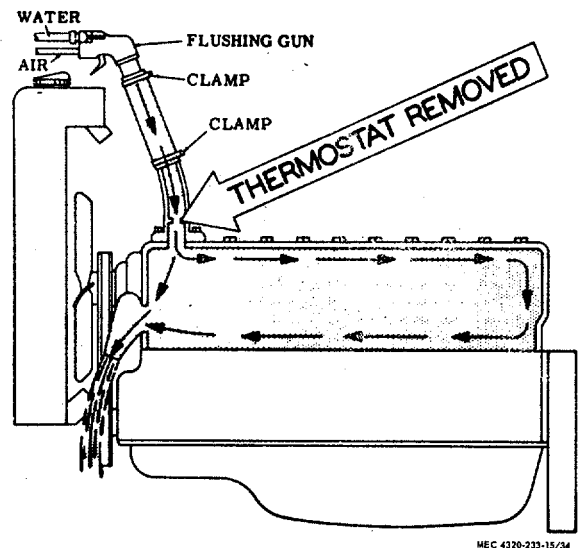

MEC 4320-233-15/34

Figure 35. Reverse flushing engine.

- e. Water forms rust due to its natural tendency to combine chemically with iron and air in the system. Use a rust inhibitor to reduce the need for cleaning and flushing.
- f. The addition of corrosion inhibitors is not necessary if an antifreeze containing a rust inhibitor is used.

g. Deposits of sludge, scale, and rust on the cooling surfaces prevent normal heat transfer from the metal surfaces to the water and, in time, make the coolant system unable to properly maintain normal operating temperatures. The appearance of rust in the radiator or coolant is a warning that the corrosion inhibitor has lost its effectiveness; clean the system before adding fresh coolant.

h. Use dependable cleaning compounds. Follow the procedure recommended by the supplier. This is of prime importance because different cleaners vary in concentration and chemical compositions. After cleaning and flushing, fill the system with an approved antifreeze compound containing a rust and corrosion inhibitor or water with a corrosion inhibitor.

i. Whenever a cooling system is badly rust clogged, as indicated by overflow loss or abnormally high operating temperatures, corrective cleaning by reverse flow flushing will most effectively remove the heavy deposits of sludge, rust, and scale. Perform the reverse flow flushing immediately after draining the cleaning solution; it is advisable to flush the radiator first, allowing the engine to cool as much as possible.

j. To reverse flush the radiator, refer to figure 34 and proceed as follows:

- (1) Disconnect the hoses at the engine.
- (2) Put the radiator cap on tightly.
- (3) Clamp the flushing gun in the lower hose with a hose clamp.
- (4) Turn on the water and let it fill the radiator.
- (5) Apply air pressure and gradually increase to 80 psi to avoid radiator damage.
- (6) Shut off the air. Again fill the radiator with water and apply air pressure; repeat until the flushing stream runs out clear.
- (7) Clean and inspect the radiator cap.

k. To reverse flush the engine water jacket, refer to figure 35 and proceed as follows:

- (1) Remove the thermostat.
- (2) Clamp the flushing gun in the upper hose.
- (3) Partly close the water pump opening to fill the engine jacket with water before applying air.
- (4) Follow the same procedure outlined above for the radiator by alternately filling the water jacket with water and blowing it out with air (80 psi pressure) until the flushing stream is clear.

## **Section VIII. LUBRICATION SYSTEM**

### **77. Description and Function**

a. General. The engine has full pressure lubrication to all main, connecting rod, and camshaft bearings, as well as the tappets and timing gears. To insure pin lubrication and prevent piston scoring during warm up in cold weather, the large end of the connecting rods have drilled spurt holes pointing toward the thrust side of the pistons. These line up with the oil hole in the crankpin so that once each revolution, oil is sprayed on the cylinder wall for lubrication.

b. Oil Pump. A large capacity, submerged, gear-type oil pump is driven off the camshaft.

c. Oil Pressure Relief Valve. An adjustable bypass valve automatically maintains suitable oil pressure from idle to maximum speed. Normal oil pressures are 40 to 50 psi at 1,800 rpm and above 7 psi at idling speed (400 to 600 rpm).

d. Oil Filter. A bypass-type oil filter removes dirt and foreign elements from the oil. The removal of grit, sludge, and foreign particles causes filter elements to clog and become ineffective unless they are regularly replaced.

### **78. Oil Filter**

a. Service (fig. 36).

- (1) Loosen the cover bolt (1) and remove the cover (3), cover gasket, cover bolt, and cover bolt gasket (2) from the body (6).
- (2) Remove the element from the body.
- (3) Remove oil from the body and clean the body with a clean, lint-free cloth.
- (4) Install a replacement element in the body.
- (5) Install a cover gasket in the cover. Position the cover (3) on the oil filter body (6); secure with the cover bolt (1) and gasket (2).
- (6) Operate the engine at fast idle for about 10 minutes. Check for oil leaks around the filter cover.

b. Removal.

- (1) Disconnect the oil tubes (4 and 15, fig. 37) at the fittings in the oil filter.
- (2) Remove the four bolts, lock washers, and nuts that secure the straps (5, fig. 36) of the oil filter to the mounting bracket (4); remove the oil filter.

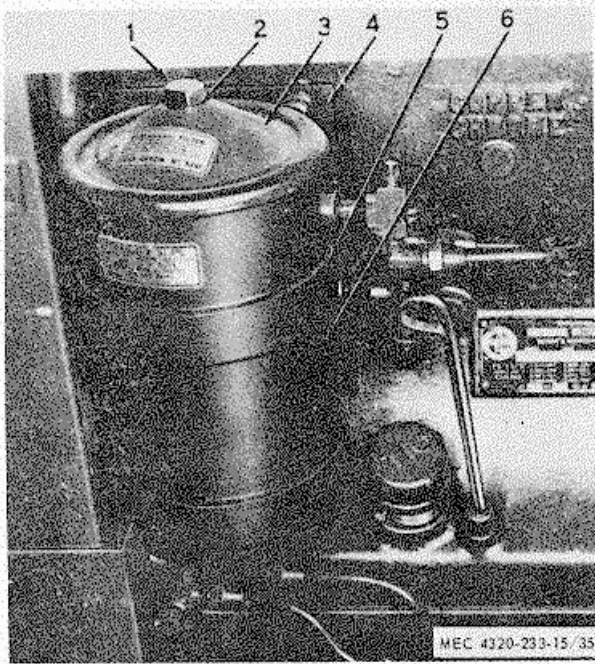

- |              |                    |
|--------------|--------------------|
| 1 Cover bolt | 4 Mounting bracket |
| 2 Gasket     | 5 Strap            |
| 3 Cover      | 6 Body             |

**Figure 86. Oil filter.**

- (3) Remove the assembled nipple (1, fig. 37), tee (3), elbow (5), and plug (2) and the elbow (16) from the oil filter.

*c. Cleaning and Inspection.*

- (1) Clean the outside of the oil filter with a cloth dampened in cleaning solvent. Service the oil filter as directed in subparagraph a above.
- (2) Inspect the oil filter, mounting parts, and fittings for cracks, breaks, restrictions, clogging, stripped threads, or other damage. Replace damaged parts.

*d. Installation.*

- (1) Position the straps (5, fig. 35) around the oil filter body (6); position the assembled oil filter and straps on the mounting bracket (4). Secure with four bolts, lockwashers, and nuts.

- (2) Install the fittings (1, 2, 3, 5, and 16, fig. 37) in the oil filter as shown in figure 37.
- (3) Connect the tubes (4 and 15) to the oil filter.

**79. Crankcase Breather Service (fig. 56)**

The crankcase breather tube is mounted on the rear valve chamber cover (90). Each time the engine oil is changed, check that the breather is not plugged. Check breather operation with the engine running. To clean the breather, remove the two nuts (91) and gaskets (92) that secure the valve chamber cover to the block (28); remove the cover and gasket (75). Clean the cover and breather tube with an approved cleaning solvent; dry with clean, dry compressed air. Position a new gasket and the valve chamber cover on the block; secure with the two nuts and gaskets.

**80. Oil Line and Fitting Replacement**

Engine oil lines and fittings are shown in figure 37. Remove and replace lines as necessary.

**81. Oil Pressure Relief Valve (fig. 56)**

*a. Adjustment.*

- (1) Remove the plug (74), performed packing (73), and spring (72) from the block (28).
- (2) Remove or add adjusting washers (71) as necessary to provide oil pressure between 40 and 50 psi while the engine is running at 1,800 rpm.
- (3) Install the spring, a new preformed packing, and the plug.
- (4) Operate the engine and check the oil pressure. Repeat (1) through (3) above until oil pressure is within acceptable limits. If the proper adjustment cannot be attained, repair or replace the oil pump.

*b. Replacement.*

- (1) Remove the plug (74), preformed packing (73), spring (72), washers (71), and valve (70) from the block (28).
- (2) Install a replacement valve, washers, a spring, preformed packing, and plug in the block.
- (3) Adjust the valve as directed in a above.

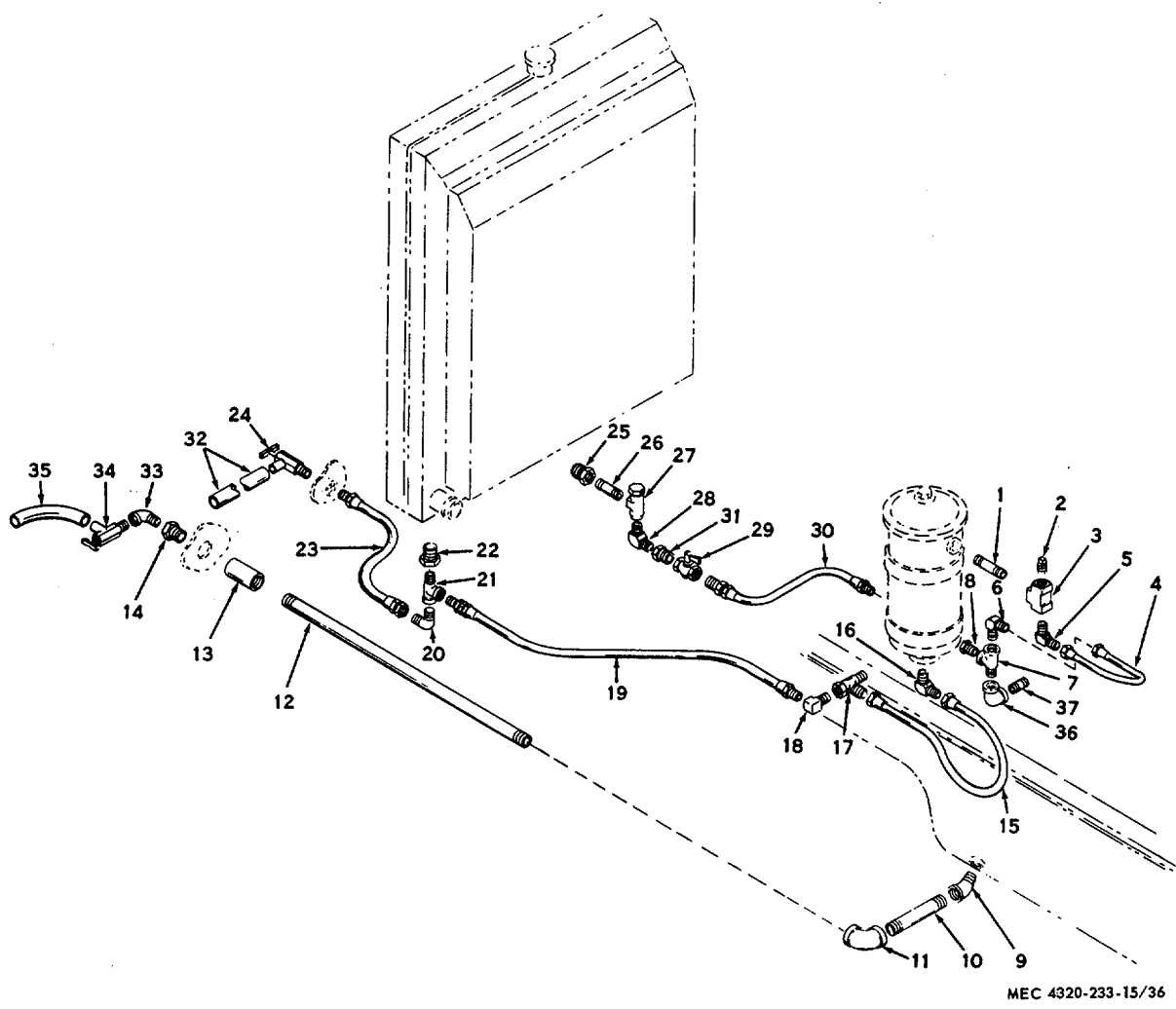

MEC 4320-233-15/36

- |                    |                     |                     |
|--------------------|---------------------|---------------------|
| 1 Nipple           | 14 Reducer bushing  | 26 Nipple           |
| 2 Pipe plug        | 15 Tube             | 27 Oil bypass valve |
| 3 Tee              | 16 Elbow            | 28 Elbow            |
| 4 Tube             | 17 Tee              | 29 Shutoff valve    |
| 5 Elbow            | 18 Elbow            | 30 Hose             |
| 6 Elbow            | 19 Hose             | 31 Reducing bushing |
| 7 Tee              | 20 Elbow            | 32 Rubber hose      |
| 8 Reducing bushing | 21 Tee              | 33 Street elbow     |
| 9 Street elbow     | 22 Reducing bushing | 34 Drain cock       |
| 10 Nipple          | 23 Hose             | 35 Rubber hose      |
| 11 Elbow           | 24 Drain cock       | 36 Elbow            |
| 12 Nipple          | 25 Reducing bushing | 37 Nipple           |
| 13 Coupling        |                     |                     |

Figure 87. Lubricating oil lines and fittings.

## Section IX. ENGINE

### 82. Description and Function

a. The internal combustion, L-head, gasoline engine is mounted on the pumping unit skids. The engine is housed by top, side, and end panels. A port is provided in the top panel for the exhaust pipe.

b. The combustible mixture of gasoline and air flows from the carburetor, through the intake manifold, into the combustion chamber. Flow of the mixture into the combustion chamber is controlled by the intake valves. The intake valves are operated by adjustable tappets which ride the lobes of the cam.

c. After the combustible mixture has been burned in the cylinder, the exhaust valves open and the exhaust gases are forced into the exhaust manifold.

Operation of the exhaust valves is controlled by tappets which ride the lobes of the cam.

d. Exhaust gases are carried from the exhaust manifold to the atmosphere through the exhaust pipe and muffler. The muffler quiets the noise of the engine.

### 83. Valve Tappet Adjustment

a. Operate the engine at fast idle until it reaches operating temperature.

b. Remove the four nuts (91, fig. 56) and gaskets (92) that secure the valve chamber covers (76 and 90) to the block (28); remove the covers and gaskets (75).

c. Set the intake valve tappet clearance at 0.017 inch and the exhaust valve tappet clearance at 0.020 inch as shown in figure 38. The second, third, fifth, eighth, tenth, and eleventh valves, starting from either end of the engine, are intake valves. The remainder are exhaust valves.

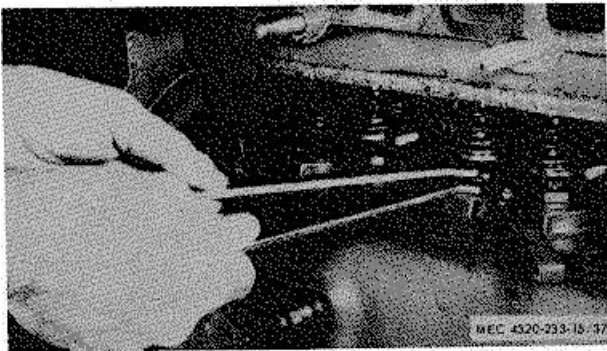

Figure 88. Valve tappet adjustment.

d. Position new gaskets and the valve chamber covers on the block; secure with the nuts and gaskets.

### 84. Muffler and Exhaust Pipe

#### a. Removal.

- (1) Remove the four screws (3, fig. 41) and lock-washers (4) that secure the muffler guard (2) to the top hood (1); remove the muffler guard.
- (2) Remove the clamp (3, fig. 39) that secures the muffler (2) to the exhaust pipe (5). Remove the screw and open the clamp of the muffler mounting bracket (11). Remove the muffler from the exhaust pipe and from the bracket.
- (3) Remove the four screws (13) that secure the bracket to the engine hood; remove the bracket and spacers (12).
- (4) Loosen the screw on the weather cap (1) and pull the weather cap from the muffler.
- (5) Use a pipe wrench to remove the exhaust pipe (5) from the exhaust flange (6); remove the exhaust pipe and rain shield (4).
- (6) Remove the four nuts (10) and washers (9) that secure the exhaust flange (6) to the exhaust manifold; remove the flange (6) and gasket (7).

#### b. Cleaning and Inspection.

- (1) Clean the parts in an approved cleaning solvent; dry with clean, dry compressed air. Scrape carbon deposits from the exhaust pipe.
- (2) Inspect the parts for holes, thin spots, heavy deposits, stripped threads, cracks, breaks, or other damage. Replace damaged parts.

c. *Installation* Installation of the muffler and exhaust pipe is the reverse of the removal procedure described in a above.

### 85. Air Preheater (fig. 40)

#### a. Removal.

- (1) Loosen the hose clamps (2 and 4) and remove the hose (3). Remove the stack cap (1).
- (2) Loosen the hose clamps (13 and 15) and remove the hose (14) from the air valve (5) to the air cleaner.

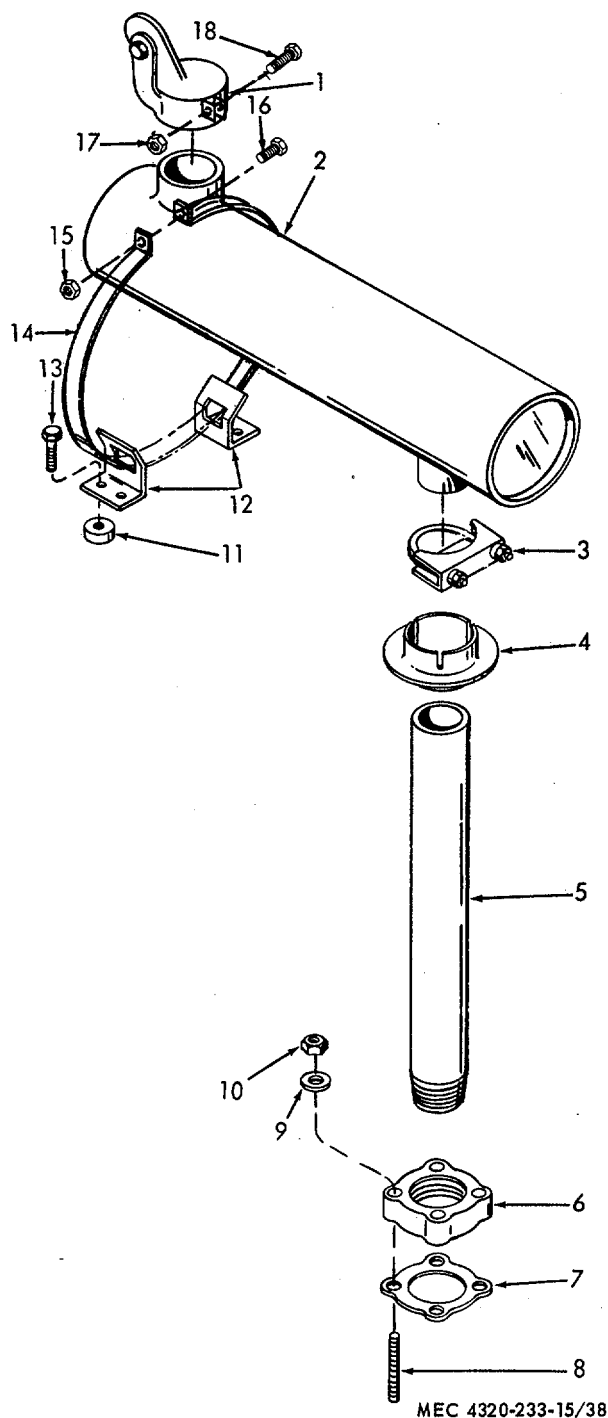

**Figure 39. Exhaust system parts, exploded view.**

- (3) Remove the clamp (6) and remove the air valve (5) from the preheater assembly (7).

**INDEX TO FIGURE 39**

1	Weather cap	10	Nut
2	Muffler	11	Mounting bracket
3	Clamp	12	Spacer
4	Rain shield	13	Screw
5	Exhaust pipe	14	Clamp
6	Exhaust flange	15	Nut
7	Gasket	16	Screw
8	Stud	17	Nut
9	Washer	18	Screw

(4) Remove the six nuts (10) and washers (9) that secure the preheater assembly to the exhaust manifold; remove the preheater and spacers (8).

(5) Remove the hose clamps (11) and remove the hose (12) that connects the air cleaner and carburetor.

**b. Cleaning and Inspection.**

(1) Clean all metal parts in an approved cleaning solvent. Wipe the hose with a damp cloth.

(2) Inspect the hose for cracks, deterioration, or damage. Inspect all other parts for cracks, breaks, stripped threads, wear, or other damage. Replace damaged parts.

c. Installation. Installation of the air preheater is the reverse of the removal procedure described in a above.

**86. Manifolds (fig. 56)**

**a. Removal.**

(1) Remove the carburetor as directed in paragraph 59b.

(2) Remove the exhaust pipe and muffler as directed in paragraph 84a.

(3) Remove the air preheater as directed in paragraph 85a.

(4) Remove the 11 nuts (80), tabbed washers (79), and washers (78) that secure the manifolds (82, 87, and 88) to the block (28); remove the manifolds and two gaskets (89).

**b. Cleaning and Inspection.**

(1) Clean the manifolds in an approved cleaning solvent. Carefully remove all carbon deposits.

(2) Inspect the gasket for damage. Inspect the manifolds for warpage, cracks, breaks, or damage. Replace damaged parts.

c. Installation. Installation of the manifolds is the reverse of the removal procedure described in a above.

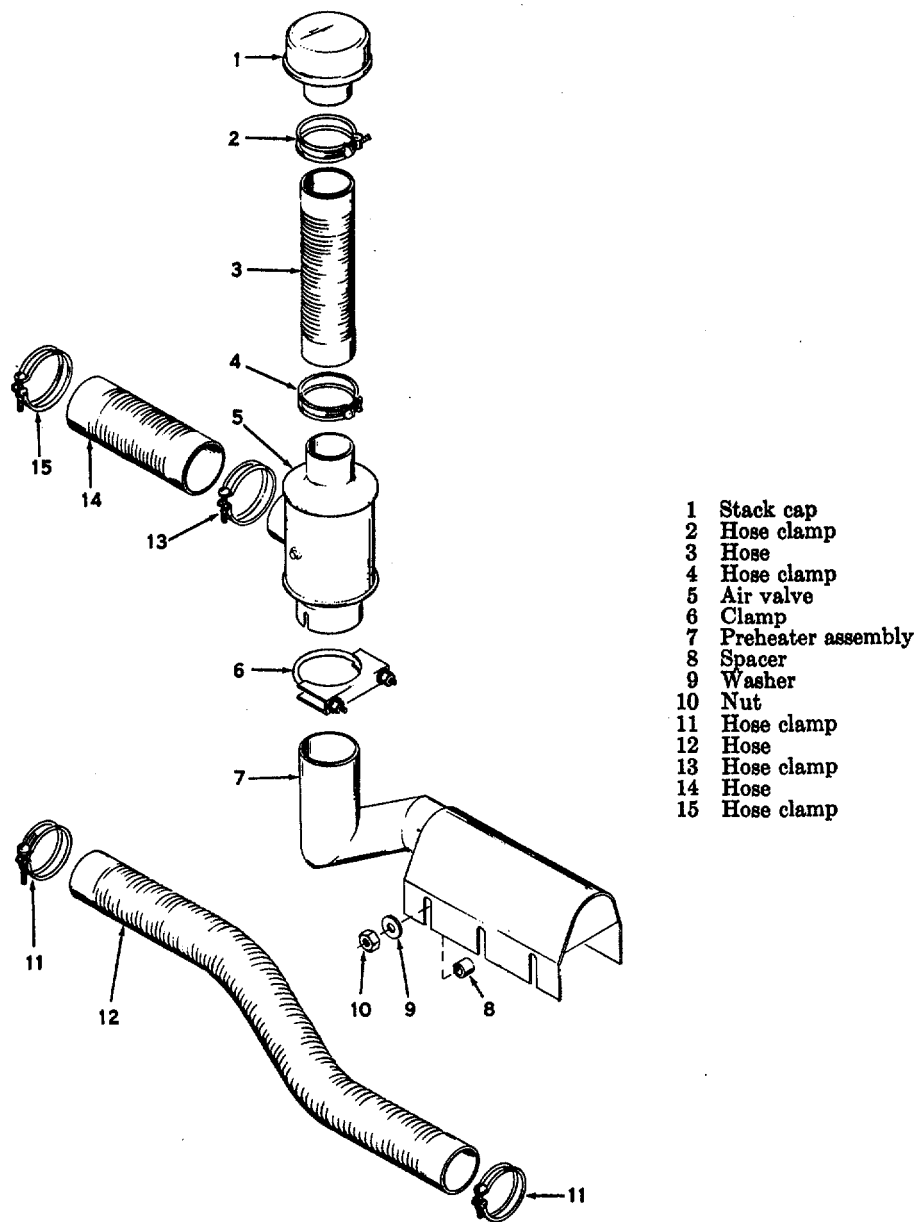

- 1 Stack cap
- 2 Hose clamp
- 3 Hose
- 4 Hose clamp
- 5 Air valve
- 6 Clamp
- 7 Preheater assembly
- 8 Spacer
- 9 Washer
- 10 Nut
- 11 Hose clamp
- 12 Hose
- 13 Hose clamp
- 14 Hose
- 15 Hose clamp

MEC 4320-233-15/39

Figure 40. Air preheater parts, exploded view.

**Section X. CONTROLS AND INSTRUMENTS**

**87. Discharge Pressure Gage**

*a. Removal.*

- (1) Disconnect the Y8-inch pipe at the discharge pressure gage (9, fig. 11).
- (2) Remove the three screws, nuts, and lockwashers that secure the gage to the instrument panel; remove the gage.

*b. Cleaning and Inspection.*

- (1) Clean the gage with a cloth dampened in cleaning solvent; wipe dry. Wash the glass carefully.
- (2) Inspect the gage for cracks, breaks, stripped threads, or other damage. If the gage is suspected of being faulty, check

against a gage of known accuracy. Replace a damaged or defective gage.

*c. Installation.* Installation of the discharge pressure gage is the reverse of the removal procedure described in a above.

### **88. Intake Pressure Gage**

#### *a. Removal*

- (1) Disconnect the F-inch pipe at the intake pressure gage (13, fig. 11).
- (2) Remove the three screws, nuts, and lockwashers that secure the gage to the instrument panel; remove the gage.

*b. Cleaning and Inspection.* Clean and inspect the intake pressure gage as directed in paragraph 87b.

*c. Installation* Installation of the intake pressure gage is the reverse of the removal procedure described in a above.

### **89. Tachometer and Hourmeter (fig. 21)**

#### *a. Removal*

- (1) Disconnect the tachometer drive cable (6) from the back of the tachometer and hourmeter (5).
- (2) Remove the two nuts and lockwashers that secure the mounting yoke to the tachometer and hourmeter; tag and disconnect panel light electrical lead. Remove the yoke and tachometer and hourmeter from the instrument panel.

#### *b. Cleaning and Inspection.*

- (1) Clean the tachometer and hourmeter with a cloth dampened in cleaning solvent.  
Wash the glass carefully.
- (2) Inspect the tachometer and hourmeter for cracks, breaks, stripped threads, or other damage. Replace if damaged.

*c. Installation* Installation of the tachometer and hourmeter is the reverse of the removal procedure described in a above.

### **90. Engine Oil Pressure Gage and Safety Switch**

#### *a. Removal.*

- (1) Tag and remove the electrical lead from the engine oil pressure gage (7, fig. 11).
- (2) Remove the oil line from the back of the gage.
- (3) Remove the two nuts and lockwashers that secure the mounting yoke to the gage; remove

the mounting yoke and gage from the instrument panel.

*b. Cleaning and Inspection.* Clean and inspect the engine oil pressure gage and safety switch as directed in paragraph 87b.

*c. Installation.* Installation of the engine oil pressure gage and safety switch is the reverse of the removal procedure describe in a above.

### **91. Ammeter**

#### *a. Removal.*

- (1) Tag and remove the three electrical leads from the ammeter (4, fig. 11).
- (2) Remove the two nuts and lockwashers that secure the mounting yoke to the ammeter; remove the yoke and ammeter from the instrument panel.

*b. Cleaning and Inspection.* Clean and inspect the ammeter in a manner similar to the one described in paragraph 87b.

*c. Installation* Installation of the ammeter is the reverse of the removal procedure described in a above.

### **92. Engine Water Temperature Gage and Safety Switch**

#### *a. Removal.*

- (1) Tag and remove she electrical lead from the engine water temperature gage (3, fig. 11).
- (2) Remove the temperature transmitting cable from the gage.
- (3) Remove the two nuts and lockwashers that secure the mounting yoke to the gage; remove the mounting yoke and gage from the instrument panel.

*b. Cleaning and Inspection.* Clean and inspect the water temperature gage and safety switch as described in paragraph 87b.

*c. Installation.* Installation of the engine water temperature gage is the reverse of the removal procedure described in a above.

### **93. Throttle Control**

#### *a. Removal.*

- (1) Disconnect the throttle cable (4, fig. 18) from the carburetor.
- (2) Remove the nut (14, fig. 21) that secures the throttle control (10) to the instrument panel; remove the throttle control.

#### *b. Cleaning and Inspection.*

- (1) Clean the control with a cloth dampened in cleaning solvent; wipe dry.



- (2) Inspect the control for cracks, breaks, stripped threads, or other damage. Replace if damaged.

*c. Installation.* Installation of the throttle control is the reverse of the removal procedure described in a above. Adjust the throttle control (para 59d(2)).

#### **94. Battery Disconnect Switch**

##### *a. Removal*

- (1) Tag and remove the electrical leads from the battery disconnect switch (7, fig. 21).
- (2) Remove control lever from front of switch.
- (3) Remove the nut that secures the switch to the instrument panel; remove the switch.

##### *b. Cleaning and Inspection.*

- (1) Wipe the switch with a cloth.
- (2) Inspect the switch for corroded terminals, cracks, breaks, or other damage. Replace if damaged.

*c. Installation.* Installation of the battery disconnect switch is the reverse of the removal procedure described in a above.

#### **95. Choke Control**

##### *a. Removal*

- (1) Disconnect the choke cable (11, fig. 18) from the carburetor.
- (2) Remove the nut that secures the choke control (13, fig. 21) to the instrument panel; remove the choke control.

*b. Cleaning and Inspection.* Clean and inspect the control as directed in paragraph 93b.

*c. Installation.* Installation of the choke control is the reverse of the removal procedure described in a above. Adjust the choke control (para 59d (1)).

#### **96. Magneto Switch**

##### *a. Removal.*

- (1) Tag and remove the leads from the back of the magneto switch (12, fig. 21).
- (2) Remove the knob from the switch.
- (3) Remove the nut and washer that secures the switch to the instrument panel; remove the switch.

*b. Cleaning and Inspection.* Clean and inspect the switch as directed in paragraph 94b.

*c. Installation.* Installation of the magneto switch is the reverse of the removal procedure described in a above.

#### **97. Starter Button**

##### *a. Removal.*

- (1) Tag and remove the leads from the back of the starter button (11, fig. 21).
- (2) Remove the nut that secures the button to the instrument panel; remove the button.

##### *b. Cleaning and Inspection.*

- (1) Wipe the starter button with a damp cloth. Dry carefully.
- (2) Inspect the terminals of the starter button for corrosion or damage. Inspect the button for cracks, breaks, or other damage; replace if damaged.

*c. Installation.* Installation of the starter button is the reverse of the removal procedure described in a above.

### **Section XI. HOOD AND SIDE PANELS**

#### **98. Description and Function**

The engine is housed in a sheet metal enclosure, the panels of which are assembled with screws. The two side panels open to provide access to the engine and its components. Latches are provided to hold the panels in the open position. The dash panel mounted at the flywheel end of the engine includes an instrument panel on which are mounted the control and instruments necessary to run the pumping unit. The instrument panel is covered by an access door which latches in either a closed or open position.

#### **99. Hood and Side Panels (fig. 41)**

##### *a. Removal.*

- (1) Remove the screws (7) and lockwashers (8) that secure the side panels (9 and 24) to the top hood (1); remove the side panels.
- (2) Remove the muffler (par 84a) and disconnect the hose from the air valve to the top hood (para 85a (1)).
- (3) Remove the 18 screws (5) and lockwashers (6) that secure the top hood (1) to the radiator shell (25) and dash (16); remove

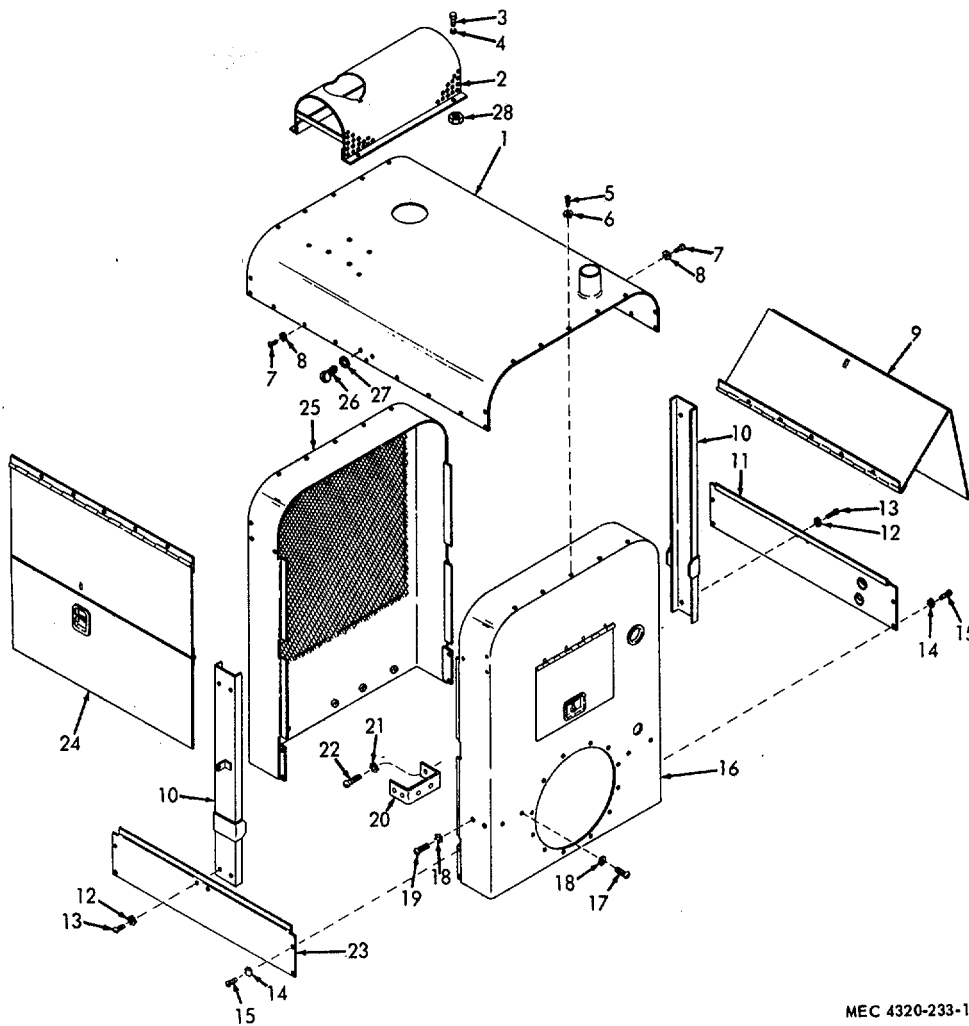

MEC 4320-233-15/40

- |                    |                           |                          |
|--------------------|---------------------------|--------------------------|
| 1 Top hood         | 11 Lower right side panel | 20 Side bracket          |
| 2 Muffler guard    | 12 Lockwasher             | 21 Lockwasher            |
| 3 Screw            | 13 Screw                  | 22 Screw                 |
| 4 Lockwasher       | 14 Lockwasher             | 23 Lower left side panel |
| 5 Screw            | 15 Screw                  | 24 Left side panel       |
| 6 Lockwasher       | 16 Dash                   | 25 Radiator shell        |
| 7 Screw            | 17 Screw                  | 26 Screw                 |
| 8 Lockwasher       | 18 Lockwasher             | 27 Nut                   |
| 9 Right side panel | 19 Screw                  | 28 Nut                   |
| 10 Brace           |                           |                          |

**Figure 41. Hood and side panels, exploded view.**

the screws that secure braces (10) to top hood; remove the top hood.

- (4) Remove the screws (13) and lockwashers (12) that secure the braces (10) to the lower side panels (11 and 23); remove the braces.
- (5) Disconnect the drain hoses from the radiator shell.
- (6) Remove 4 screws (15, fig. 41) and lockwashers (14) that secure the lower side TAGO 63W8A panels (11 and 23) to the radiator shell and

dash; disconnect fuel lines (12 and 37, fig. 22) from plugs (31); remove lower side panel and radiator shell.

- (7) The dash cannot be removed without removal of the pump and should not be attempted at this level of maintenance.

**b. Cleaning and Inspection.**

- (1) Clean parts in an approved cleaning solvent; dry with clean, dry compressed air.

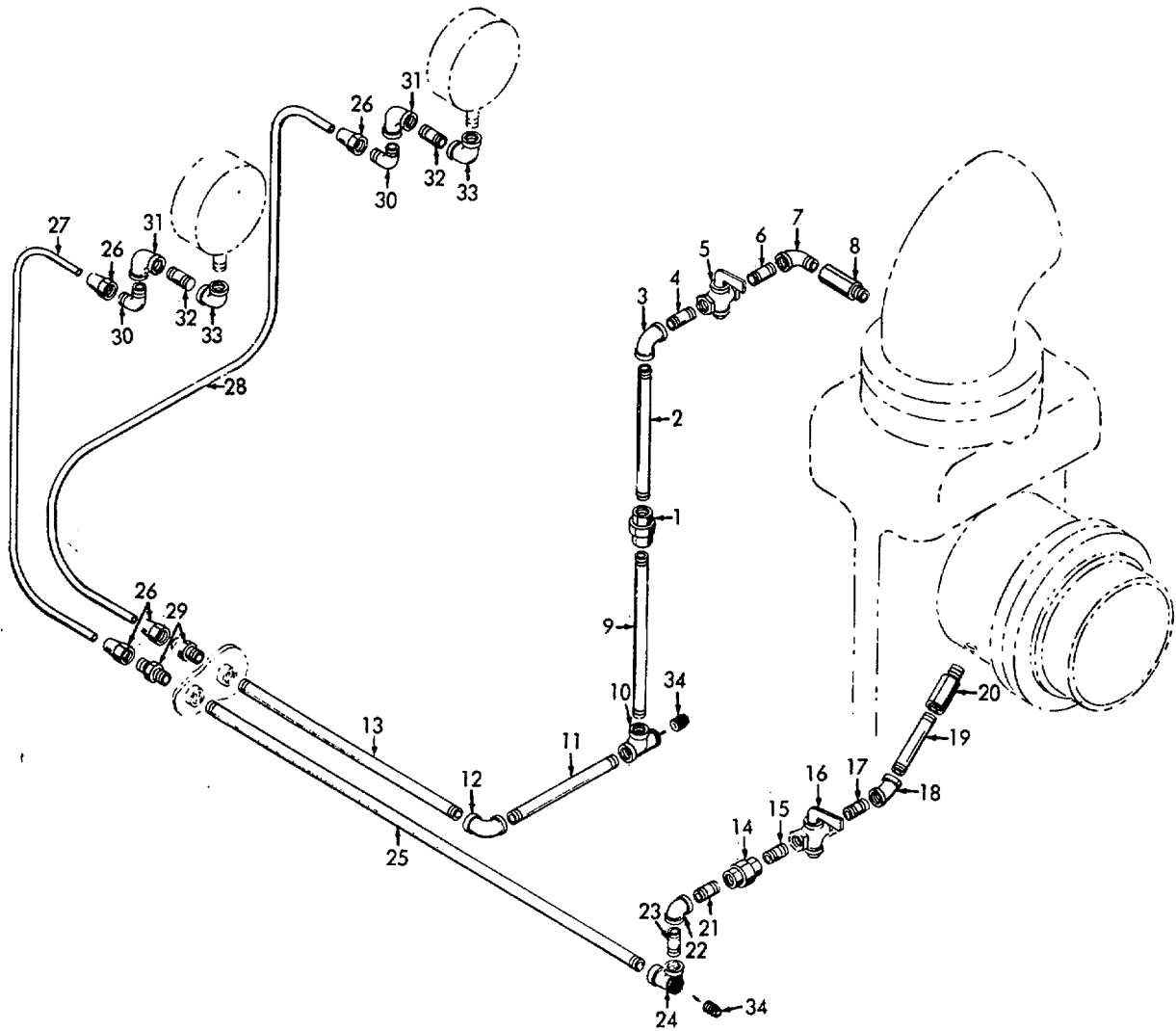

MEC 4320-233-15/40.1

- |                     |                      |                    |
|---------------------|----------------------|--------------------|
| 1 Union, pipe       | 13 Nipple, pipe      | 24 Tee             |
| 2 Nipple, pipe      | 14 Union, pipe       | 25 Nipple, pipe    |
| 3 Elbow, 90°        | 15 Nipple, pipe      | 26 Nut, union      |
| 4 Nipple, pipe      | 16 Cock, shutoff     | 27 Tubing, copper  |
| 5 Cock, shutoff     | 17 Nipple, pipe      | 28 Tubing, copper  |
| 6 Nipple, pipe      | 18 Elbow, 45°        | 29 Connector, male |
| 7 Elbow, street     | 19 Nipple, pipe      | 30 Elbow           |
| 8 Valve, restrictor | 20 Valve, restrictor | 31 Elbow, 90°      |
| 9 Nipple, pipe      | 21 Nipple, pipe      | 32 Nipple, brass   |
| 10 Tee              | 22 Elbow, 90°        | 33 Elbow, 90°      |
| 11 Nipple, pipe     | 23 Nipple, pipe      | 34 Plug            |
| 12 Elbow, 90°       |                      |                    |

**Figure 42. Lines and fittings.**

(2) Inspect parts for cracks, bends, dents, breaks, enlarged holes, or other damage; replace if damaged.

c. Installation. Installation of the hood and side panels is the reverse of the removal procedure described in a above.

## Section XII. DISCHARGE AND INTAKE PRESSURE LINES

### 99.1. General

The discharge pressure line runs from the discharge side of the pump to the discharge pressure gage located on the control panel. The intake pressure line runs from the intake side of the pump to the intake pressure gage located on the control panel.

### 99.2 Discharge and Intake Pressure Lines

a. *Removal and Disassembly* Refer to figure 42 to remove and disassemble the discharge and intake pressure lines.

b. *Cleaning and Inspection.*

- (1) Clean all parts in an approved cleaning solvent and dry thoroughly.
- (2) Inspect parts for cracks, bends, breaks, or other damage, replace all missing or damaged parts.

c. *Reassembly and Installation.* Refer to figure 42 to reassemble and install the discharge and intake pressure lines.

#### Note

**Drain the condensate every 24 hours under normal operating condition, after every shutdown, and every 4 hours in subfreezing temperature. To drain turn the valves (5 and 16, fig. 42) to the OFF position then remove plug (34) from gage line. In the event no readings or incorrect readings on the pressure gages, remove items 8 and 20 and clean thoroughly with solvent or compressed air.**

**CHAPTER 4**  
**DIRECT AND GENERAL SUPPORT AND DEPOT MAINTENANCE INSTRUCTIONS**

**Section I. ENGINE REPAIR AND REPLACEMENT STANDARDS**

*Table III. Engine Repair and Replacement Standards*

Components	Manufacturers dimensions and tolerances		Desired clearance	Allowable clearance		Allowable wear
	Minimum	Maximum		Minimum	Maximum	
Cylinder						
Diameter.....	4.000	4.002				.008
Overbore.....		.040				
Pistons						
Pin Hole Diameter.....	1.1151	1.1153				
Ring Groove Diameters						
Compression.....	3.546	3.556				
Oil.....	3.562	3.572				
Rings						
Width #1.....	.0925	.0935				
2 and 3.....	.0925	.0935				
4.....	.248	.249				
Thickness #1.....	.195	.200				
2 and 3.....	.162	.172				
4.....	.162	.172				
Gap Clearance 1, 2, 3 and 4.....				.013	.025	
Side Clearance						
1, 2, and 3.....				.003	.005	
4.....				.001	.003	
Piston Pin						
Length.....	3.242	3.257				
Diameter.....	1.149	1.151				.002
Diameter Piston Pin Hole in Rod.....	1.169	1.170				
Diameter Pin Bushing.....	1.151	1.154				.002
Piston Pin Clearance in Bushing.....			.00025	.0000	.0005	
Piston Pin Fit in Piston.....			Light Push	.0000	.0004	
Valve Guides, Intake						
Stem Hole Diameter.....	.3423	.3431				.0015
Valve Seat Face to Top of Guide.....	1¼ in.	1¼ in.				
Guide to Valve Stem Clearance.....			.0015	.0008	.0026	
Valve Guide, Exhaust						
Stem Hole Diameter.....		.3452	.3460			.0015
Valve Seat Face to Top of Guide.....	1⅞	1⅞				
Guide to Valve Stem Clearance.....			.0045	.0037	.0055	
Intake Valve						
Stem Diameter.....	.3405	.3415				.002
Head Diameter.....	1 <sup>58</sup> / <sub>64</sub>					
Seat Angle.....	45°					
Exhaust Valve						
Stem Diameter.....	.3405	.3415				.002
Head Diameter.....	1½ in.					
Seat Angle.....	45°					

TAGO 6358-A

Table III. Engine Repair and Replacement Standards-Continued

Components	Manufacturers dimensions and tolerances		Desired clearance	Allowable clearance		Allowable wear
	Minimum	Maximum		Minimum	Maximum	
<b>Camshaft</b>						
Journal Diameters #1.....	2.1840	2.1850				.001
2.....	2.1215	2.1225				.001
3.....	2.0590	2.0600				.001
4.....	1.7465	1.7475				.001
Tappet Hole Diameter.....	1.125	1.125				
Tappet Diameter.....	1.12375	1.12425				
Tappet to Tappet Hole Clearance.....				.00075	.00225	
End Play.....				.005	.009	
<b>Camshaft Bushings</b>						
Inside Diameter #1.....	2.1865	2.1870				
2.....	2.1240	2.1245				
3.....	2.0615	2.0620				
4.....	1.7490	1.7495				
Bushing to Shaft Clearance #1.....				.0015	.0025	
2.....				.0015	.0025	
3.....				.0015	.0025	
4.....				.0015	.0025	
<b>Connecting Rods</b>						
Bushing Hole Diameter.....	1.169	1.170				
Bearing Hole Diameter.....	2.3740	2.3745				
Side Play.....			.006 Min	.006	.010	
Bearing Thickness.....	.0618	.0628				Min thickness.
Bearing to Rod Clearance.....			.0015	.0009	.0029	
<b>Main Bearings</b>						
Thickness.....	.0950	.0953				Min thickness.
Bearing to Shaft Clearance.....			.002	.0005	.0038	
<b>Crankshaft</b>						
Main Bearing Journal.....	2.623	2.624				.001
Crankpin Journal.....	2.2466	2.2475				.001
End Thrust.....				.005	.008	
Flywheel Runout.....		.002 ind. reading.				
<b>Oil Pump</b>						
Bear Backlash.....				.003	.0065	
Gear to Cover Clearance.....				.0015	.006	
Gear to Housing Clearance.....				.001	.003	
<b>Valve Springs</b>						
Valve Closed						
Spring Length.....		1.875 in.				
Spring Load.....	58 lb	64 lb				
Valve Open						
Spring Length.....		1.521 in.				
Spring Load.....	115 lb	123 lb				

Section II. REMOVAL OF MAJOR ITEMS

100. Coupling  
(fig. 43)

a. Removal

Remove pump (para 101) or assembled engine (para 102) and remove coupling as follows:

- (1) Remove the eight bolts (4) and nuts (6) that join the coupling halves (5) together.

Slide the coupling halves back onto the shafts.

- (2) Loosen retaining ring (1) and one of the hubs (3) from its shaft and remove the key. Slide the coupling half (5) with its assembled seal (2) and retaining ring (1) from the shaft.

- (3) Snap loose retaining ring (1), drive remaining coupling half from hub, attach puller and pull hub (3), seal (2), and retaining ring (1) from shaft.

**b. Disassembly** The coupling is partially disassembled during removal. To complete disassembly, remove the retaining rings (1) and remove the seals (2) from the hubs (3).

- (1) Scrape all grease from the coupling parts. Wash all metal parts with an approved cleaning solvent; dry thoroughly.
- (2) Discard the seals (2).
- (3) Inspect the hubs (3) and coupling halves (5) for cracks, chipped, worn, or broken gear teeth, or other damage. Replace the seals and any damaged parts.

**d. Assembly** Install the seals (2) in the hubs (3); secure with retaining rings (1). Complete assembly during installation.

**e. Installation**

- (1) Position the coupling halves (5) with their assembled seals (2) and retaining rings (1) on the shafts. Install the keys in the shaft keyways and tap the hubs (3) onto the shafts.
- (2) Pull the coupling halves together so that the bolt holes are aligned; secure with eight bolts (4) and nuts (6).

**101. Pump**

**a. Removal.**

- (1) Disconnect the intake pressure gage piping (5, fig. 44) and the discharge pressure gage piping (1) from the pump.
- (2) Remove the eight bolts (4, fig. 43) and nuts (6) that secure the coupling halves together.
- (3) Remove the six mounting bolts (6 and 7, fig. 44) that secure the pump to the skid base; remove the pump.

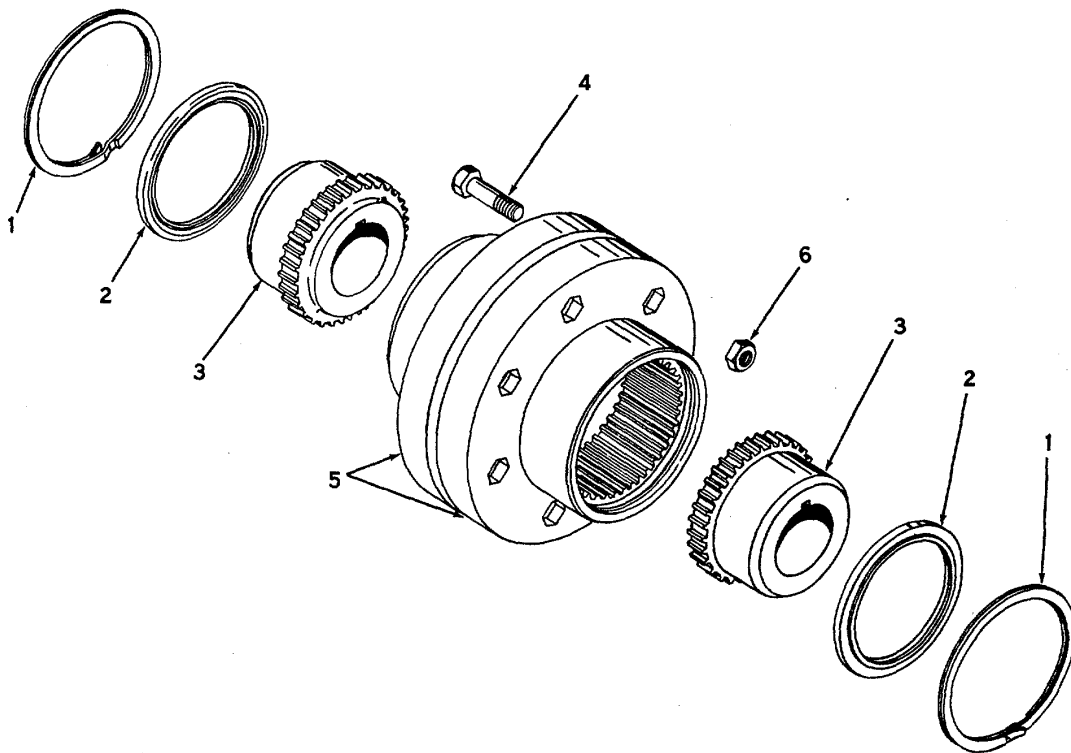

MEC 4320-233-15/41

1 Retaining ring  
2 Seal

3 Hub  
4 Bolt

5 Coupling half  
6 Nut

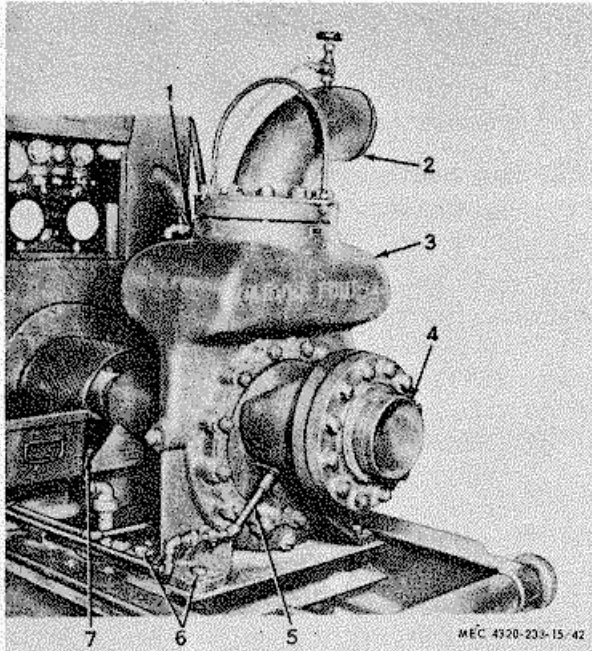

- |                                  |                               |
|----------------------------------|-------------------------------|
| 1 Discharge pressure gage piping | 5 Intake pressure gage piping |
| 2 Discharge elbow                | 6 Mounting bolts              |
| 3 Pump                           | 7 Mounting bolts              |
| 4 Intake nipple                  |                               |

**Figure 44. Pump installation.**

- (4) Remove the coupling hub (3, fig. 43), key, and coupling half with its assembled seal (2) and retaining ring (1) from the pump shaft.

**b. Cleaning and Inspection.**

- (1) Clean the outside of the pump with a cloth dampened with cleaning solvent; wipe dry. Take care not to let solvent enter the pump.
- (2) Inspect the pump for cracks, breaks, bent or scored shaft, or other damage; refer to higher authority if damaged.

**c. Installation.**

- (1) Position the coupling half (5) with the assembled seal (2) and retaining ring (1) on the pump shaft. Position the key in the keyway of the pump shaft and install the hub (3) on the shaft.
- (2) Position the pump on the skid base. Use a straightedge to make sure the pump shaft is perfectly aligned with the engine shaft. Shim under the pump as necessary to provide correct alignment of the shafts.
- (3) Secure the pump to the skid base with six mounting bolts (6 and 7, fig. 44).

- (4) Recheck the shaft alignment between the engine and pump. If all alignment is correct, position the coupling halves together and secure with eight bolts (4, fig. 47 and nuts (6).

**102. Assembled Engine, Stub Shaft, and Dash**

**a. Removal.**

- (1) Remove the eight bolts (4, fig. 43) and nuts (6) that secure the coupling halves together.
- (2) Remove the side panels and top hood from the engine (para 98).
- (3) Remove the eight engine mounting bolts (5, fig. 45) and lockwashers that secure the engine to the skid base. A lifting eye is provided on one of the cylinder head studs to facilitate hoisting the engine. Remove the engine from the skid base.
- (4) Pull the coupling hub (3, fig. 43) and key from the stub shaft on the engine and remove the coupling half (5) with its assembled seal (2) and retaining ring (1).

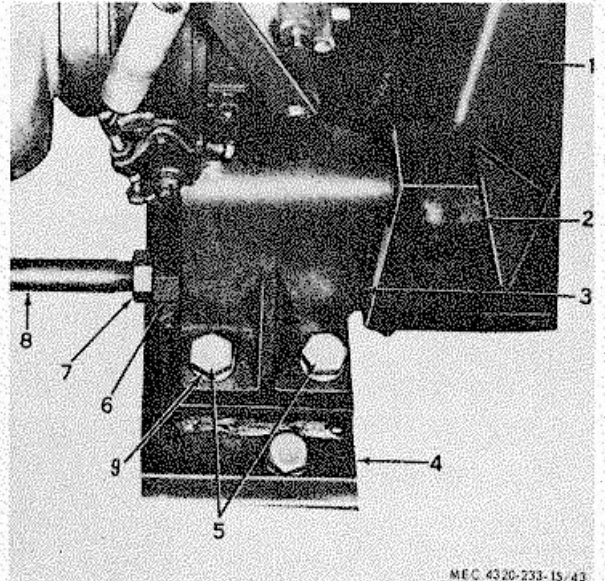

- |                         |              |
|-------------------------|--------------|
| 1 Radiator shroud       | 6 Nut        |
| 2 Radiator mount        | 7 Nut        |
| 3 Engine mount          | 8 Tie rod    |
| 4 Engine mounting block | 9 Lockwasher |
| 5 Engine mounting bolts |              |

**Figure 45. Engine mounting.**



b. *Cleaning and Inspection.*

- (1) Clean the outside of the engine with a cloth dampened with cleaning solvent; wipe dry. Take care not to allow solvent on hoses, electrical parts, or inside the engine.
- (2) Inspect the engine for loose mounting parts cracks, leaks, defective hoses or tubes, breaks, signs of failure, or other damage. Refer a damaged or defective engine to higher authority.

c. *Installation.*

- (1) Position the coupling half (5) with the assembled seal (2) and retaining ring (1) on the stub shaft mounted at the flywheel end of the engine. Install the key and coupling hub (3) on the shaft.
- (2) Using a hoist, position the engine on the skid base. Use a straightedge to assure that the pump shaft and stub shaft are exactly aligned and the distance between shafts is 4 inches. Install shims under the engine to provide correct alignment of shafts. Install the engine mounting bolts (5, fig. 43) and lockwashers to secure the engine to the skid base. Recheck shaft alignment after tightening the mounting bolts. Realign and reshim if necessary.

- (3) Position the coupling halves (5, fig. 43) together and secure with eight bolts (4) and nuts (6).
- (4) Install the side panels and top hood on the engine (para 99).

**103. Stub Shaft and Drive**

(fig. 46)

- a. *Removal.* The stub shaft and drive mounted on the flywheel housing of the engine can be removed after removing the pump (para 101) or after removing the assembled engine (para 102a). Normally, it is easier to remove the pump. The removal procedure is the same for either method.

- (1) Remove the 12 bolts (11) and lockwashers (12) that secure the thrust plate (4) to the flywheel housing; remove the thrust plate and assembled stub shaft (10), ball bearing (5), retaining rings (3 and 6), and seals (2 and 7).
- (2) Match-mark the drive adapter to the flywheel. Remove the four bolts (13) and lockwashers (14) that secure the drive adapter to the flywheel of the engine; remove the drive adapter.
- (3) Remove the keys (9) from the stub shaft.

b. *Stub Shaft Disassembly.*

- (1) Install two Y-20 x 1-inch capscrews in the threaded holes of the bushing (8). Attach

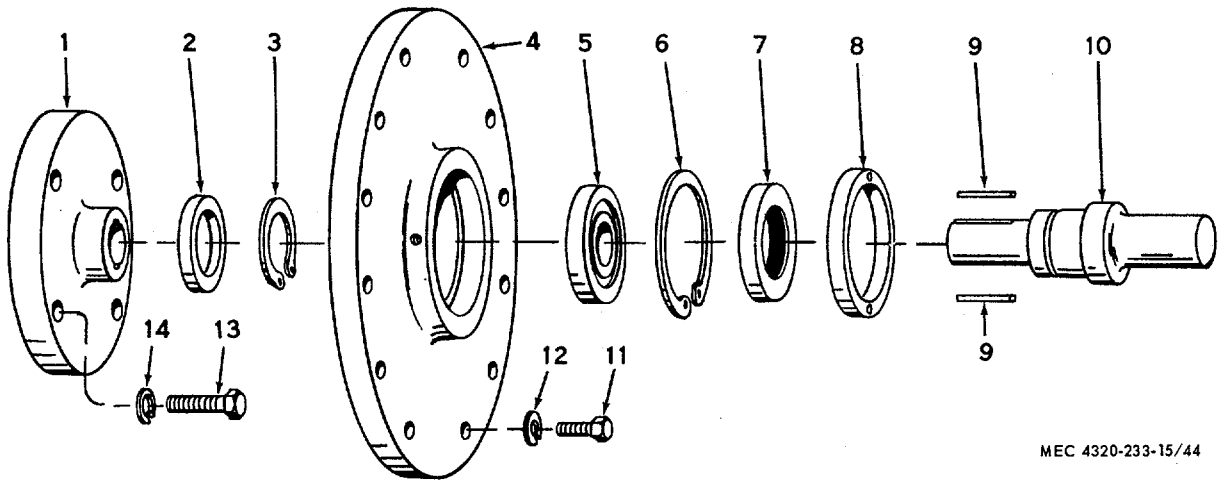

- |                  |                  |               |
|------------------|------------------|---------------|
| 1 Adapter        | 6 Retaining ring | 11 Bolt       |
| 2 Seal           | 7 Seal           | 12 Lockwasher |
| 3 Retaining ring | 8 Bushing        | 13 Bolt       |
| 4 Thrust plate   | 9 Key            | 14 Lockwasher |
| 5 Ball bearing   | 10 Stub shaft    |               |

Figure 46. Stub shaft and drive, exploded view.

a puller to the screws and pull the bushing and seal (7) from the thrust plate (4).

- (2) Use a pair of external ring pliers to remove the retaining ring (6) from the thrust plate. Press the assembled stub shaft (10) and ball bearing (5) from the thrust plate.
- (3) Use a pair of internal retaining ring pliers to remove the retaining ring (3) and press ball bearing (5) from stub shaft (10).
- (4) Remove the seal (7) from the bushing (8) and remove the seal (2) from the thrust plate.

c. *Stub Shaft Cleaning and Inspection.*

- (1) Discard the seals.
- (2) Place the ball bearing in a wire basket and agitate it in a container of clean solvent until all grease and dirt is removed. After cleaning, dry thoroughly with compressed air, taking care not to spin the bearing with air blast. Dip bearing in light engine oil.
- (3) Clean all other parts with an approved cleaning solvent; dry thoroughly.
- (4) Inspect the ball bearing for cracked or scored races, galled or rough balls, and rough or catching operation. Replace the ball bearing if there is any doubt of its condition.
- (5) Inspect the stub shaft and the thrust plate for cracks, distortion, worn bearing seats, damaged retaining ring seats, or other damage.
- (6) Inspect all other parts for cracks, distortion, or other damage; replace damaged parts.

d. *Stub Shaft Assembly.*

- (1) Press the ball bearing (5) on the stub shaft (10), taking care to support the inner race of the bearing. Secure with the retaining ring (3). Press the ball bearing against the retaining ring.
- (2) Install the retaining ring (6) in the thrust plate (4). Pack the ball bearing with grease and press the shaft and bearing assembly into the thrust plate until the bearing bottoms against the retaining ring.
- (3) Install the seal (7) in the bushing (8) and press the assembled seal and bushing into its seat on the thrust plate. Install the seal (2) in the opposite side of the thrust plate.
- (4) Rotate the stub shaft to make sure it turns freely in the bearing.

e. *Installation.*

- (1) Position the drive adapter (1) on the flywheel, aligning the match marks at

removal; secure with four bolts (13) and lockwashers (14).

- (2) Install the keys (9) in the keyways of the stub shaft (10) and position the assembled thrust plate (4) and stub shaft on the engine flywheel housing so that the keyways of the shaft engage the keyways of the adapter plate. Tap the thrust plate with a plastic hammer until it is fully seated on the flywheel, housing; secure with 12 bolts (11) and lockwashers (12).

## 104. Dash

(fig. 41)

a. *Removal.*

- (1) Remove hood and side panels from engine (para 99a).
- (2) Remove the air cleaner from the dash (para 60b).
- (3) Remove the instruments and controls from the instrument panel (para 87 through 97).
- (4) Remove the generator regulator (para 68).
- (5) Remove the stub shaft and drive (para 103a).
- (6) Remove the nuts and washers from the tie rods that extend through the dash.
- (7) Remove the eight screws (17 and 19) and lockwashers (18) that secure the dash (16) to the side brackets (20); remove the dash.
- (8) Remove the four screws (22) and lockwashers (21) that secure the side brackets to the flywheel housing; remove the brackets.

b. *Cleaning and Inspection.*

- (1) Clean the dash with an approved cleaning solvent.
- (2) Inspect the dash for bends, cracks, breaks, or other damage; replace if damaged.

c. *Installation.*

- (1) Position side brackets (20) on flywheel housing; secure with four screws (22) and lockwashers (21).
- (2) Position the dash (16) on the engine side brackets; secure with eight screws (17 and 19) and lockwashers (18).
- (3) Install the nuts and washers on the tie rods that extend through the dash.
- (4) Install the stub shaft and drive (para 103).
- (5) Install the generator regulator (para 68).
- (6) Install the instruments and controls on the instrument panel (para 87 through 97).
- (7) Install the air cleaner on the dash.
- (8) Install the remaining housing parts on the engine (para 99).

### Section III. ENGINE SPEED GOVERNOR

#### 105. Description and Function

The governor is an engine-lubricated, centrifugal, variable speed, flyball type that controls speed by adjusting the amount of travel of the control rod to the carburetor. The governor shaft gear is driven by the camshaft timing gear. As the camshaft timing gear rotates, the drive assembly balls are pressed against the outer slant of the race assembly to push the race upward. The race assembly in turn presses against the

lever and shaft assembly which is connected to the carburetor throttle control through a direct linkage. The throttle plate is closed by this action, slowing the engine to governed speed. As the engine slows, less pressure is exerted by the balls, and the race assembly moves inward. This movement is transferred through the linkage to the carburetor throttle control to increase fuel flow to the engine and increase engine speed. Engine speed is regulated in this manner.

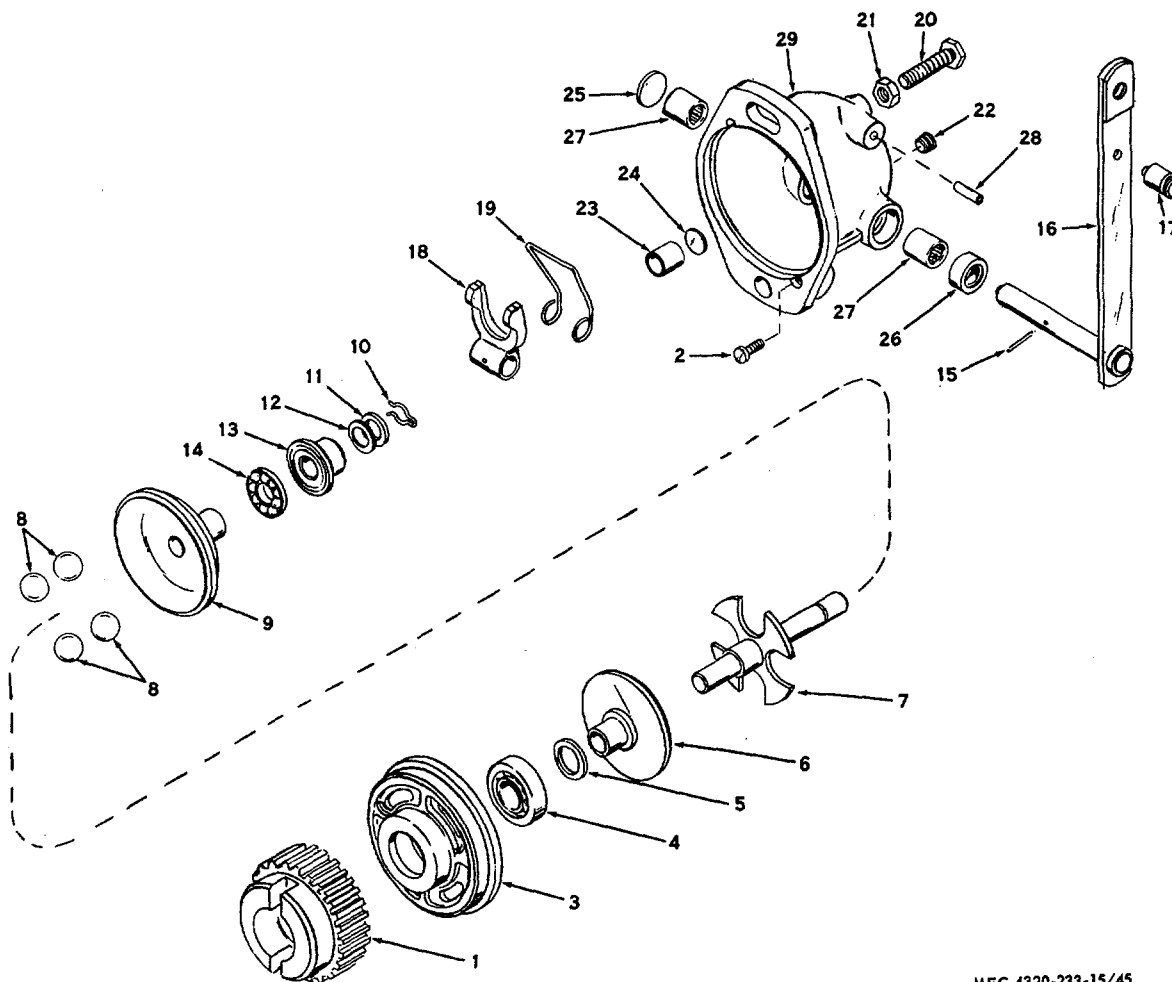

MEC 4320-233-15/45

- |                             |                   |                   |
|-----------------------------|-------------------|-------------------|
| 1 Drive gear                | 11 Thrust washer  | 21 Nut            |
| 2 Screw                     | 12 Thrust washer  | 22 Plug           |
| 3 Base assembly             | 13 Fork base      | 23 Bushing        |
| 4 Ball bearing              | 14 Thrust bearing | 24 Thrust washer  |
| 5 Thrust washer             | 15 Pin            | 25 Welch plug     |
| 6 Lower race                | 16 Lever assembly | 26 Seal           |
| 7 Shaft and driver assembly | 17 Spring pin     | 27 Needle bearing |
| 8 Ball                      | 18 Fork           | 28 Roll pin       |
| 9 Upper race                | 19 Bumper spring  | 29 Body assembly  |
| 10 Retaining clip           | 20 Screw          |                   |

Figure 47. Governor, exploded view.

## 106. Governor Repair

(fig. 47)

a. *Removal* Remove the governor (para 6d).

b. *Disassembly* Disassemble the governor in order of the index numbers assigned to figure 47. Observe the following special instructions.

- (1) Press the drive gear (1) from the shaft and driver assembly (7).
- (2) Drive the pin (15) from the fork (18) and the shaft of the lever assembly (16); remove the lever assembly, fork, and bumper spring (19) from the body assembly.
- (3) Insert a drift through the seal (26) and drive out the welch plug (25). Insert the drift from the opposite side and drive out the seal and needle bearing (17). Reinstall the drift from the seal side of the housing and drive remaining needle bearing from body (29).

c. *Cleaning and Inspection.*

- (1) Clean all metal parts except bearings in an approved cleaning solvent; dry with clean, dry compressed air. Clean bearings by placing in a strainer and dipping in a clean solution of cleaning solvent. Flush until clean.

### Caution

**Do not spin balls or needles when bearings are without lubricant. Keep bearings covered so dirt and dust will not enter.**

- (2) Repack bearings with clean bearing grease.
- (3) Inspect bearings for smooth rotation without rough or catchy spots. Inspect races, balls, and needles for wear or damage. Replace damaged bearings.

- (4) Inspect all other parts for cracks, breaks, wear, stripped or damaged threads, worn or chipped teeth, or other damage. Replace damaged parts.

d. *Assembly* Assemble the governor in reverse order of disassembly. Observe the following special instructions:

- (1) Press the plug end needle bearing (27) into the body until it is flush with the inside edge of the bearing bore in the housing. Press the second needle bearing into the housing until it is flush with the seal counterbore in the housing. Tap in the welch plug (25) and press the seal (26) into the body until it seats in the counterbore.
- (2) Insert the shaft of the lever assembly (16) into the body assembly (29) and through the fork (18) and bumper spring (19). Align the pin hole in the fork with the pin hole in the lever assembly shaft; install the pin (15).
- (3) Make sure the upper race (9) and lower race (6) turn freely when installed on the shaft and driver assembly (7).
- (4) After the shaft and driver assembly, upper and lower races, balls, thrust bearing (14), fork base (18), thrust washers (11 and 12), and retaining clip (10) have been assembled, adjust upper race free travel to 0.230 to 0.240 inch by removing or installing thrust washers (11 and 12).
- (5) Press the drive gear (1) onto the shaft and driver assembly.

e. *Installation* Install the governor (para 6d).

## Section IV. ENGINE ELECTRICAL SYSTEM

### 107. Description and Function

A 24-volt battery provides the power necessary to operate the starting motor. When the starter switch is depressed, a circuit through the solenoid switch is completed. When energized, the solenoid switch engages the pinion on the starter drive with the engine ring gear and then closes the circuit to the starting motor to crank the engine. The ignition system, simultaneously energized by the magneto, fires the fuel mixture in the engine cylinders. When the engine is running, it drives the generator to recharge the batteries; the rate of charge is controlled by a generator regulator which also provides reverse current protection.

### 108. Generator Repair

a. *Removal* Remove the generator (para 6b).

b. *Disassembly* Disassemble the generator in order of the index numbers assigned to figure 48. Do not remove the field coils unless testing indicates them to be defective.

c. *Cleaning, Inspection, and Repair.*

- (1) Wipe all parts of the generator, except the brushes, with a cloth lightly dampened in an approved cleaning solvent; dry thoroughly with low pressure compressed air. Wipe brushes with clean, dry cloth.

TAGO 6358-A

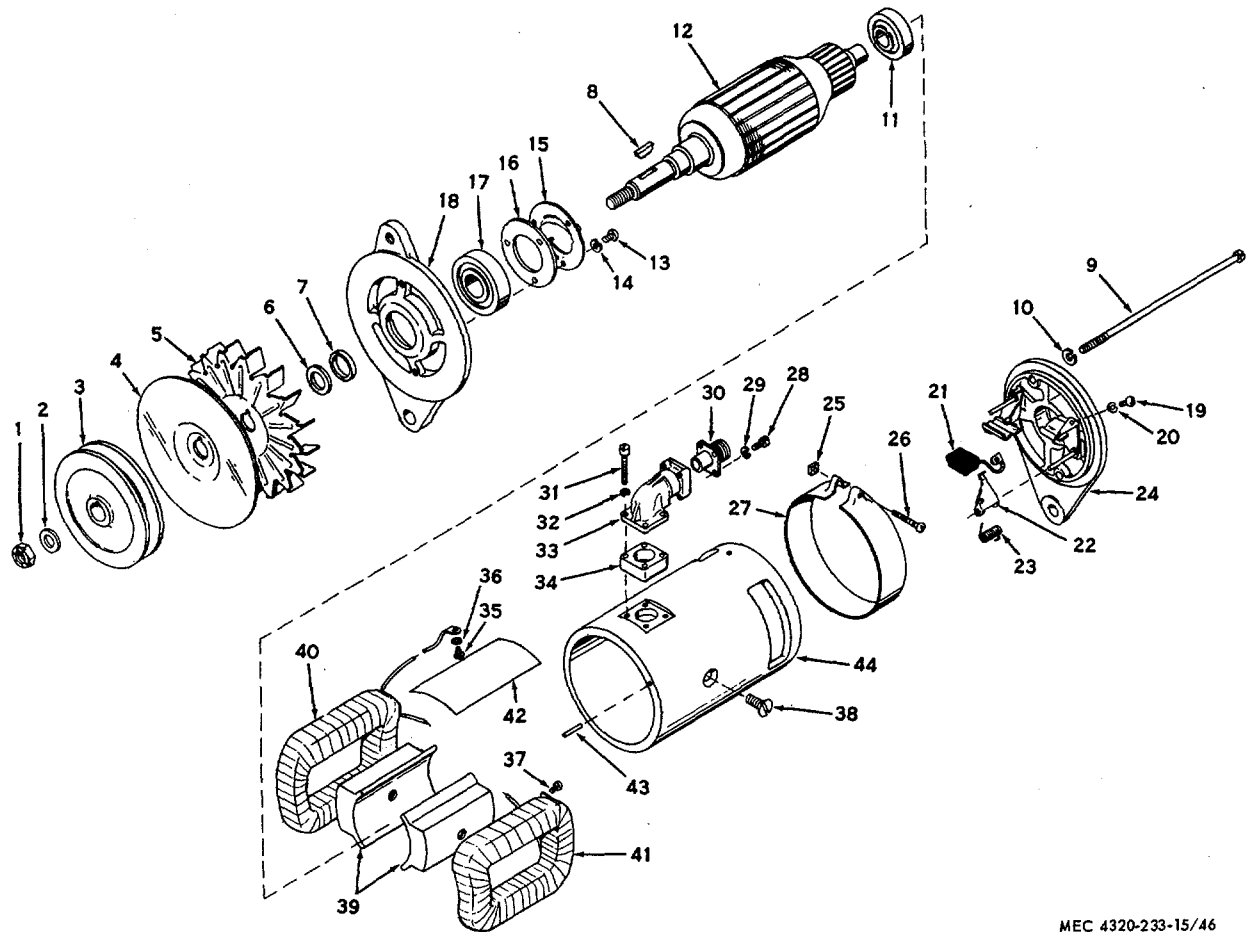

MEC 4320-233-15/46

- |                 |                 |                       |
|-----------------|-----------------|-----------------------|
| 1 Nut           | 16 Retainer     | 31 Screw              |
| 2 Washer        | 17 Ball bearing | 32 Lockwasher         |
| 3 Pulley        | 18 Head         | 33 Elbow              |
| 4 Baffle        | 19 Screw        | 34 Spacer             |
| 5 Fan           | 20 Lockwasher   | 35 Screw              |
| 6 Spacer        | 21 Brush        | 36 Lockwasher         |
| 7 Spacer        | 22 Brush arm    | 37 Screw              |
| 8 Key           | 23 Spring       | 38 Pole shoe screw    |
| 9 Thru bolt     | 24 Head         | 39 Pole shoe          |
| 10 Lockwasher   | 25 Nut          | 40 Field coil (left)  |
| 11 Ball bearing | 26 Screw        | 41 Field coil (right) |
| 12 Armature     | 27 Cover band   | 42 Insulation         |
| 13 Screw        | 28 Screw        | 43 Dowel pin          |
| 14 Lockwasher   | 29 Lockwasher   | 44 Frame              |
| 15 Spring plate | 30 Receptacle   |                       |

Figure 48. Generator, exploded view.

TAGO 6358-A

- (2) Check the size of the brushes; replace them if they are less than one-half inch in length.
- (3) Inspect the armature commutator for roughness, out-of-round, or high mica. If any of these conditions exist, turn the commutator down on a lathe and undercut the mica 12 inch. Remove only enough stock to make the commutator smooth and round. After undercutting, finish the commutator with No. 00 sandpaper. Clean all particles from the commutator and armature using low pressure, dry, compressed air. Check the armature for short circuits as described in (6), below.

**Caution**

**Always blow particles off the commutator in the direction away from the armature windings.**

- (4) Check the brush holders for distortion, cracks, breaks, or other damage; replace damaged brush holders.
- (5) Replace the brush springs if tension is less than 28 ounces.
- (6) Check for short circuits in the armature by rotating the armature on a growler with a steel strip such as a hacksaw blade held firmly on the armature. The steel strip will vibrate on the area of the short circuit. Short circuits usually are caused by particles between commutator bars. If short circuits are found, clean spaces between the commutator bars using an undercutting tool and cleaning thoroughly with compressed air. If a short circuit cannot be corrected, replace the armature.
- (7) Check for open circuits by inspecting for loose connections at the points where the conductors are connected to the commutator risers. Open circuits can be checked electrically by determining if continuity exists between adjacent commutator bars. Continuity must exist. Open circuits cause arcing and burning of the commutator. If the bars are not badly burned, resolder the leads and turn the commutator down on a lathe. Undercut the mica and test for short circuits as described in (6) above. If the open circuit cannot be corrected, replace the armature.

- (8) Check for grounds by checking the armature with a test lamp. Place one probe of the test lamp on the armature core and the other on each commutator bar in turn. If the test lamp lights, the armature is grounded. If grounded, clean it thoroughly and recheck for grounds. If ground cannot be corrected, replace the armature.
- (9) Check the field coils for grounds by checking the coils with a test lamp. Place one probe of the test lamp on the field frame assembly and the other on the field coil leads. If the test lamp lights, the field coils are grounded. Replace the field coils if a ground is indicated.
- (10) Check the field coils for open circuits by checking with a test lamp. Connect the probes of the lamp to the two leads from the coils. If the lamp does not light, the coil is open. Replace the field coils if the circuit is open.

*d. Assembly* Assemble the generator in reverse order of disassembly.

*e. Installation* Install the generator (para 60).

**109. Starting Motor Repair**

(fig. 49)

- a. Removal* Remove the starting motor (para 69 a).
- b. Disassembly* Disassemble the starting motor in order of the index numbers assigned to figure 47. Do not remove the field coils unless tests indicate them to be defective.

*c. Cleaning, Inspection, and Repair.*

- (1) Clean the armature, field frame assembly, and solenoid switch assembly with a cloth lightly dampened in an approved cleaning solvent.
- (2) Clean all other parts of the starting motor, except the brushes, in an approved cleaning solvent; dry thoroughly with compressed air.
- (3) Check the size of the brushes; replace them if they are less than 1182 inch in length.
- (4) Inspect the armature commutator for roughness, out-of-round or high mica. If any of these conditions exist, turn the commutator down on a lathe and undercut the mica 12 inch. Remove only enough stock to make the commutator smooth and round. After undercutting, finish the commutator with No. 00 sandpaper. Clean

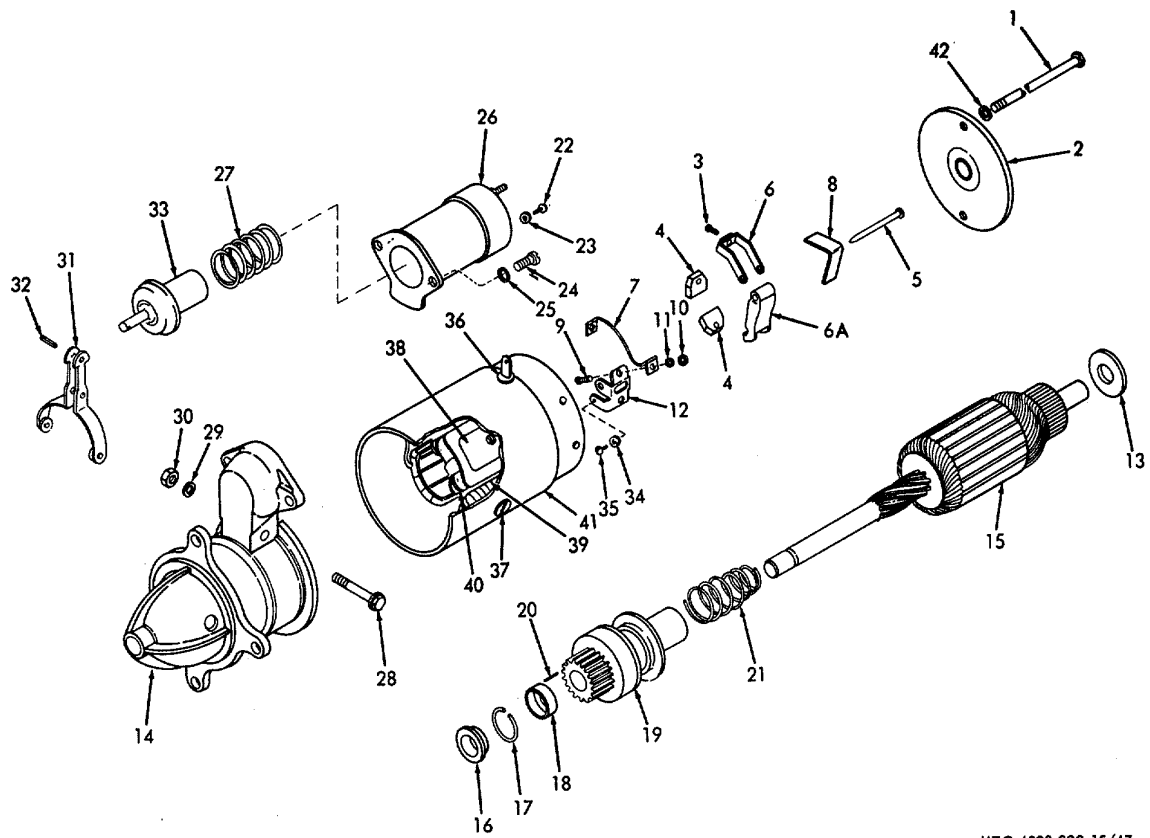

MEC 4320-233-15/47

- |                  |                      |                |
|------------------|----------------------|----------------|
| 1 Bolt           | 14 End bell          | 28 Bolt        |
| 2 End bell       | 15 Armature          | 29 Lockwasher  |
| 3 Screw          | 16 Thrust collar     | 30 Nut         |
| 4 Brush          | 17 Retaining ring    | 31 Shift lever |
| 5 Pin            | 18 Retainer          | 32 Pin         |
| 6 Brush holder   | 19 Drive assembly    | 33 Plunger     |
| 6A Brush holder  | 20 Key               | 34 Lockwasher  |
| 7 Lead           | 21 Spring            | 35 Screw       |
| 8 Spring         | 22 Screw             | 36 Grommet     |
| 9 Screw          | 23 Lockwasher        | 37 Screw       |
| 10 Nut           | 24 Screw             | 38 Pole shoe   |
| 11 Lockwasher    | 25 Lockwasher        | 39 Field coil  |
| 12 Brush bracket | 26 Solenoid assembly | 40 Field coil  |
| 13 Washer        | 27 Spring            | 41 Housing     |

Figure 49. Starting motor, exploded view.

#### INDEX TO FIGURE 50

- |                 |                          |                                 |
|-----------------|--------------------------|---------------------------------|
| 1 Lead seal     | 16 Plain washer          | 31 Insulating base              |
| 2 Screw         | 17 Screw                 | 32 Screw                        |
| 3 Plain washer  | 18 Plain washer          | 33 Receptacle                   |
| 4 Seal strip    | 19 Resistor (marked 400) | 34 Seal                         |
| 5 Cover         | 20 Nut                   | 35 Capacitor assembly           |
| 6 Screw         | 21 Bracket               | 36 O-ring                       |
| 7 Plain washer  | 22 Voltage regulator     | 37 Screw                        |
| 8 Lead          | 23 Current regulator     | 38 Receptacle and lead assembly |
| 9 Nut           | 24 Cutout relay          | 39 Gasket                       |
| 10 Connector    | 25 Elastic stop nut      | 40 Screw                        |
| 11 Screw        | 26 R. F. choke           | 41 Bracket                      |
| 12 Nut          | 27 Screw                 | 42 Pipe plug                    |
| 13 Plain washer | 28 Plain washer          | 43 O-ring                       |
| 14 Screw        | 29 Resistor (marked 60)  | 44 Base                         |
| 15 Nut          | 30 Resistor (marked 200) |                                 |

TAGO 6358-A

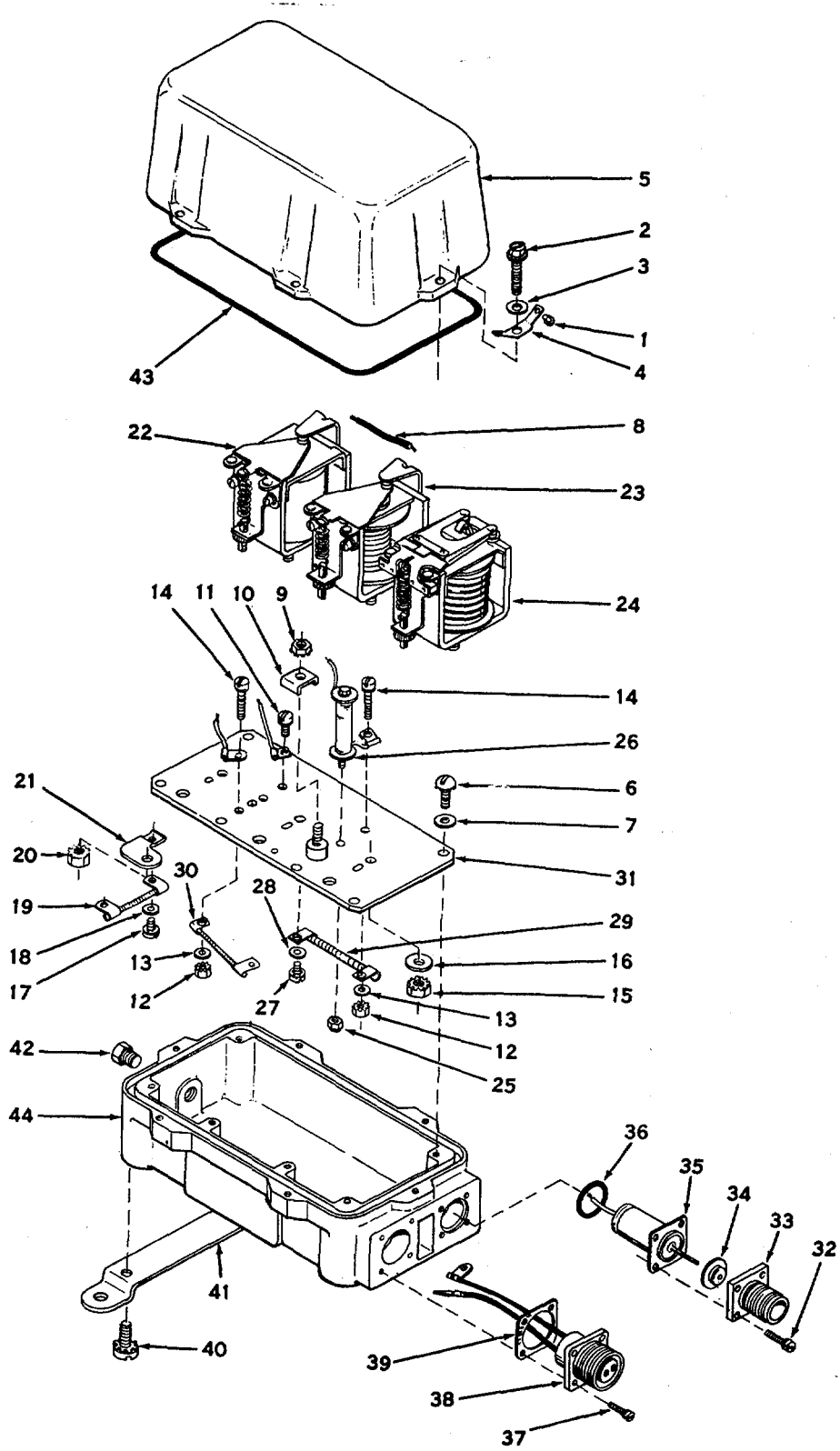

MEC 4320-233-15/47.1

Figure 50. Generator regulator, exploded view.

TAGO 6358-A



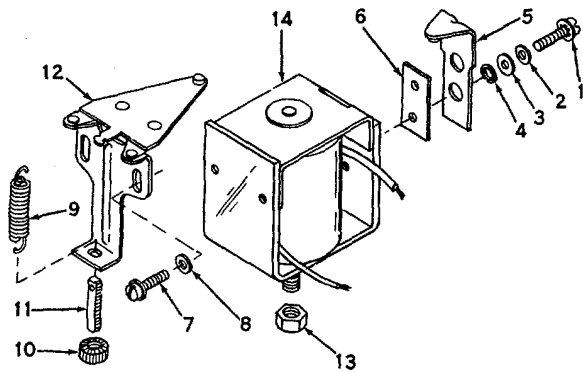

MEC 4320-233-15/47.2

- |                             |                    |
|-----------------------------|--------------------|
| 1 Screw                     | 8 Washer           |
| 2 Plain washer              | 9 Spring           |
| 3 Insulating washer         | 10 Adjusting nut   |
| 4 Insulating washer         | 11 Adjusting screw |
| 5 Air gap adjusting bracket | 12 Armature        |
| 6 Insulation                | 13 Nut             |
| 7 Screw                     | 14 Coil            |

Figure 51. Voltage regulator, exploded view.

all particles off commutator using compressed air. Check armature for short circuits (para 108c(6)).

**Caution**

**Always blow particles off the commutator in the direction away from the armature windings.**

- (5) Check the brush holders for distortion, cracks, breaks, or other damage; replace damaged brush holders.
- (6) Inspect the drive assembly for cracks, breaks, clutching action, or other damage; replace the drive assembly if any parts are damaged.
- (7) Check the armature and field windings for short circuits, grounds, and open circuits using the same method described for the generator parts (para 106). Replace the starting motor if the armature of the field windings is shorted, grounded, or open.
- (8) If removed, replace the bushing in the drive housing. Replace the springs if brush tension is not 24 to 28 ounces.

*d. Assembly* Assemble the starting motor in the reverse order of disassembly. Observe the following special instructions.

- (1) Place the spring (21) and drive assembly (19) on the shaft of the armature (15). Slide the retainer (18) on the shaft with the cupped side out. Force the retaining ring (17) over the end of the shaft and position it into the groove provided. Position the thrust collar (16) on the shaft and against the

retaining ring. Use two pairs of pliers to force thrust collar over ring.

- (2) If brushes have been replaced, seat them using No. 00 sandpaper before assembling the end frame. Blow the brush particles off the commutator so that they will not cause a short circuit during operation.
- (3) Check the pinion clearance after reassembly by connecting the starting motor and a battery in the circuit. Disconnect the motor field lead from the solenoid motor terminal.

**Caution**

**Insulate the motor field lead carefully to avoid arcing during the checking procedure.**

- (4) Momentarily touch the jumper lead from the solenoid motor terminal to the motor frame. This will shift the pinion into cranking position. It will stay in this position until the battery is disconnected.
- (5) Push the pinion back toward the commutator end to eliminate all slack movement. Measure the distance between the pinion gear of the drive assembly (19) and the retainer (18). If clearance is not between 0.010 and 0.140 inch, disassemble the starting motor as described in b above, and

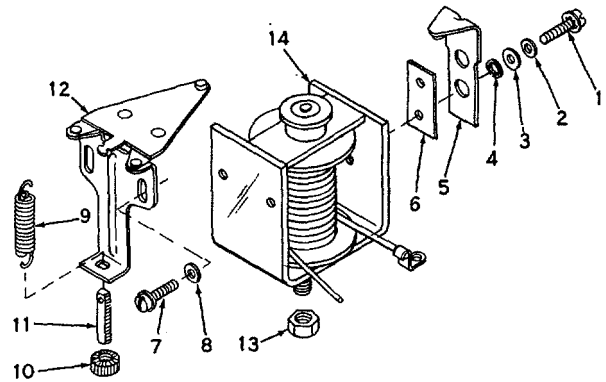

MEC 4320-233-15/47.3

- |                             |                    |
|-----------------------------|--------------------|
| 1 Screw                     | 8 Washer           |
| 2 Plain washer              | 9 Spring           |
| 3 Insulating washer         | 10 Adjusting nut   |
| 4 Insulating washer         | 11 Adjusting screw |
| 5 Air gap adjusting bracket | 12 Armature        |
| 6 Insulation                | 13 Nut             |
| 7 Screw                     | 14 Coil            |

Figure 52. Current regulator, exploded view.

check alignment of the retainer (18) on the retaining ring (17).

e. *Testing* Refer to paragraph 69.

### 109.1. Generator Regulator Repair

a. *Removal* Remove the generator regulator (para. 68b).

b. *Disassembly* Disassemble the generator regulator in the order of the index numbers assigned to figures 50, 51, 52, 53, and 54.

c. *Cleaning and Inspection.*

(1) Clean all electrical parts with a cloth lightly dampened in an approved cleaning solvent.

(2) Clean all other parts in an approved cleaning solvent; dry thoroughly.

(3) Inspect all parts for serviceability and damage; replace unserviceable parts.

d. *Assembly* Assemble the generator regulator in the reverse order of disassembly.

e. *Installation* Install the generator regulator (para 68b).

### 110. Magneto Repair

(fig. 54)

a. *Removal* Remove the magneto (para 70).

b. *Disassembly* Disassemble the magneto in order of the index numbers assigned to figure 54. Note the following special instructions:

(1) Pull the impulse coupling hub (39) from the shaft (50) with a suitable puller.

(2) Remove the bearing support plate (44) from the frame (54). Press the bearing (46) from the bearing support plate.

(3) Remove the shaft (50) from the frame. Press the bearing races (48) from the shaft.

(4) Press the bearing (46) and seal (51) from the frame.

c. *Cleaning and Inspection.*

(1) Clean the housing (5) gasket (6), preformed packing (8), and distributor block with a wet, soapy cloth. Rinse and wipe dry.

(2) Clean all metal parts except bearings in an approved cleaning solvent; dry with clean, dry compressed air.

(3) Clean, inspect, and lubricate bearings as directed in paragraph 106c.

(4) Clean the electrical parts with a cloth dampened in an approved cleaning solvent.

(5) Inspect the electrical parts for corrosion, cracks, breaks, frayed insulation, damaged terminals, or evidence of failure. Replace if damaged or defective.

(6) Inspect the spring (38) for wear, cracks, damage, or loss of tension; replace if damaged or deformed.

(7) Inspect gear teeth for chips, breaks, wear, or damage; replace if damaged.

(8) Test the condenser on a standard condenser tester.

(9) Inspect all other parts for cracks, breaks, wear, or other damage. Replace if damaged.

d. *Assembly* Assemble magneto in reverse order of disassembly; observe following special instructions:

(1) Press the bearings(46) and seal (51) into the frame (54).

(2) Press the one bearing race (48) onto the shaft (50). Slide the shims (49) onto the shaft, and press the second bearing race onto the shaft against the shims.

(3) Press the bearing (46) into the bearing support plate (44).

(4) Install the assembled shaft and bearings in the frame. Slide the assembled bearing support plate and bearing onto the shaft and into position on the frame; secure with the two screws (42) and washers (43).

(5) Press the impulsecoupling hub (39) onto the shaft.

(6) Set contact point gap at 0.008 to 0.012 inch.

(7) Set the arrow on the stop pin plate (41) opposite the 30° mark on the frame.

e. *Installation* Install the magneto (para 70).

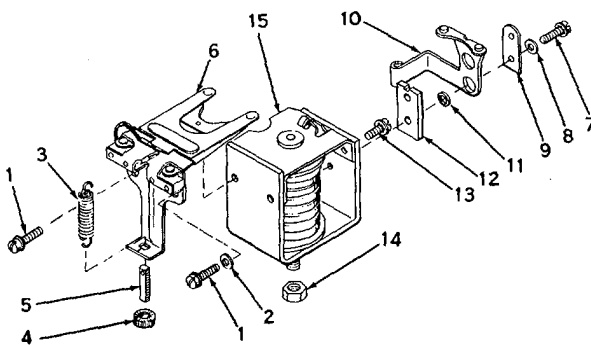

MEC 4320-233-15/47.4

1 Screw	9 Insulation
2 Plain washer	10 Stationary contact
3 Spring	11 Insulation washer
4 Adjusting nut	12 Insulation
5 Adjusting screw	13 Screw
6 Armature	14 Nut
7 Screw	15 Coil
8 Plain washer	

Figure 53. Cutout relay, exploded view.

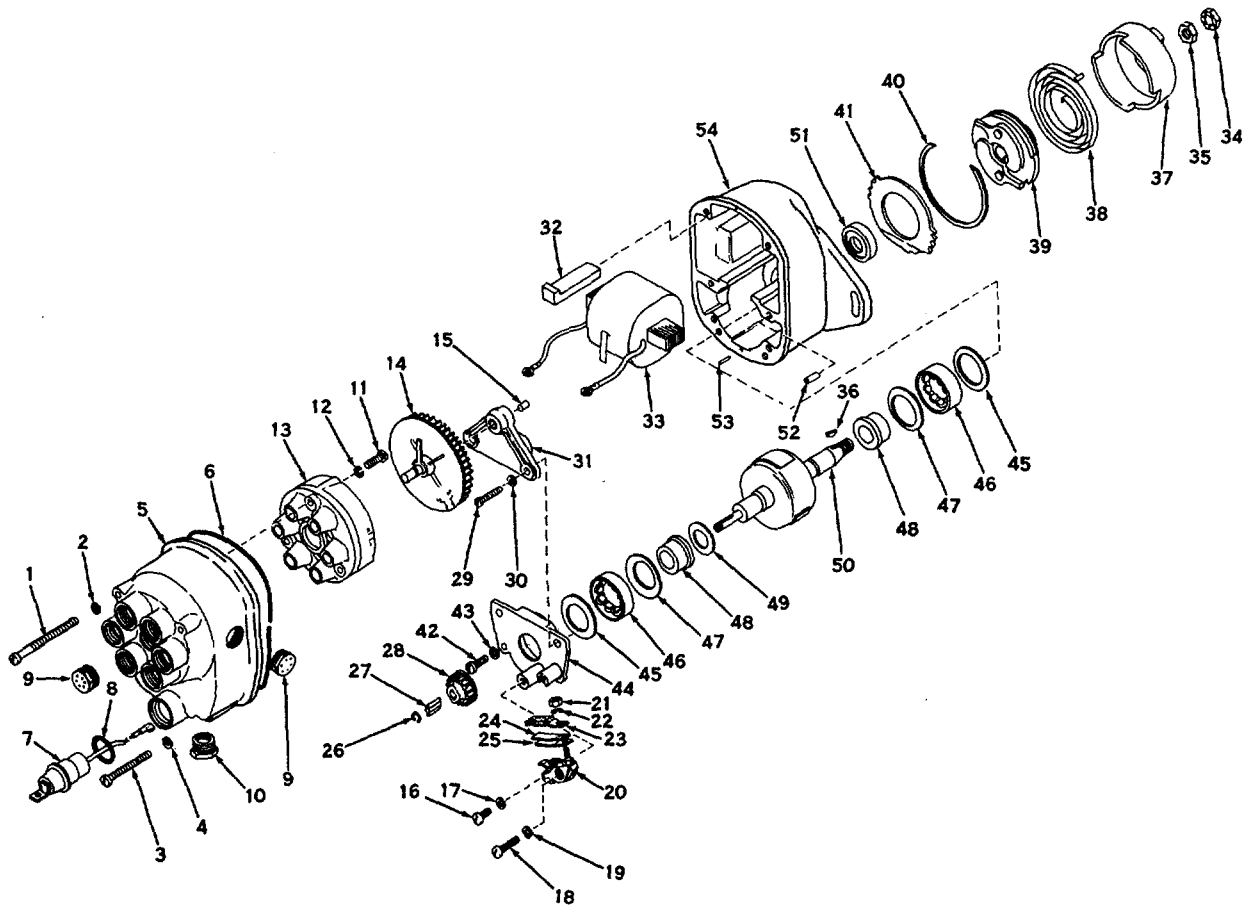

MEC 4320-233-15/48

- |    |                   |    |                   |    |                       |
|----|-------------------|----|-------------------|----|-----------------------|
| 1  | Screw             | 19 | Washer            | 37 | Shell                 |
| 2  | Washer            | 20 | Contact point set | 38 | Spring                |
| 3  | Screw             | 21 | Nut               | 39 | Hub                   |
| 4  | Washer            | 22 | Lockwasher        | 40 | Retaining ring        |
| 5  | Housing           | 23 | Insulator         | 41 | Stop pin plate        |
| 6  | Gasket            | 24 | Cam follower      | 42 | Screw                 |
| 7  | Condenser         | 25 | Brush             | 43 | Washer                |
| 8  | Preformed packing | 26 | Retaining ring    | 44 | Bearing support plate |
| 9  | Vent              | 27 | Cam               | 45 | Washer                |
| 10 | Plug              | 28 | Gear              | 46 | Bearing               |
| 11 | Screw             | 29 | Screw             | 47 | Washer                |
| 12 | Washer            | 30 | Washer            | 48 | Bearing race          |
| 13 | Distributor block | 31 | Bearing plate     | 49 | Shim                  |
| 14 | Distributor gear  | 32 | Wedge             | 50 | Shaft                 |
| 15 | Brush             | 33 | Coil              | 51 | Seal                  |
| 16 | Screw             | 34 | Pal nut           | 52 | Bushing               |
| 17 | Washer            | 35 | Locknut           | 53 | Pin                   |
| 18 | Screw             | 36 | Woodruff key      | 54 | Frame                 |

Figure 54. Magneto, exploded view.

## Section V. COOLANT SYSTEM

### 111. Description and Function

a. All component repair of the coolant system, except radiator and water pump repair, is covered in chapter 3.

b. The radiator consists of a series of tubes through which the coolant is circulated. Fins are attached to the tubes to give a more extended surface through which heat can be dissipated. For most effective use, these fins must be kept clean and free from accumulated dirt.

c. The water pump is a centrifugal-type water pump of standard design. It is driven from the engine crankshaft by the fan and generator belt. The water pump circulates coolant through the engine and radiator.

### 112. Radiator Repair

a: Removal

- (1) Drain the coolant system.
- (2) Remove the top and rear housing panels (para 99a).
- (3) Loosen the radiator hose clamps (1 and 9, fig. 32). Disconnect the radiator hoses from the radiator. Disconnect the hose assembly (17) from the radiator. Disconnect the oil inlet and oil outlet piping from the radiator (fig. 37).
- (4) Remove the screws, nuts, and lockwashers that secure the radiator mounts (fig. 45) to the front engine mounts (3); remove the radiator. Remove the liners between the radiator and radiator mounts.

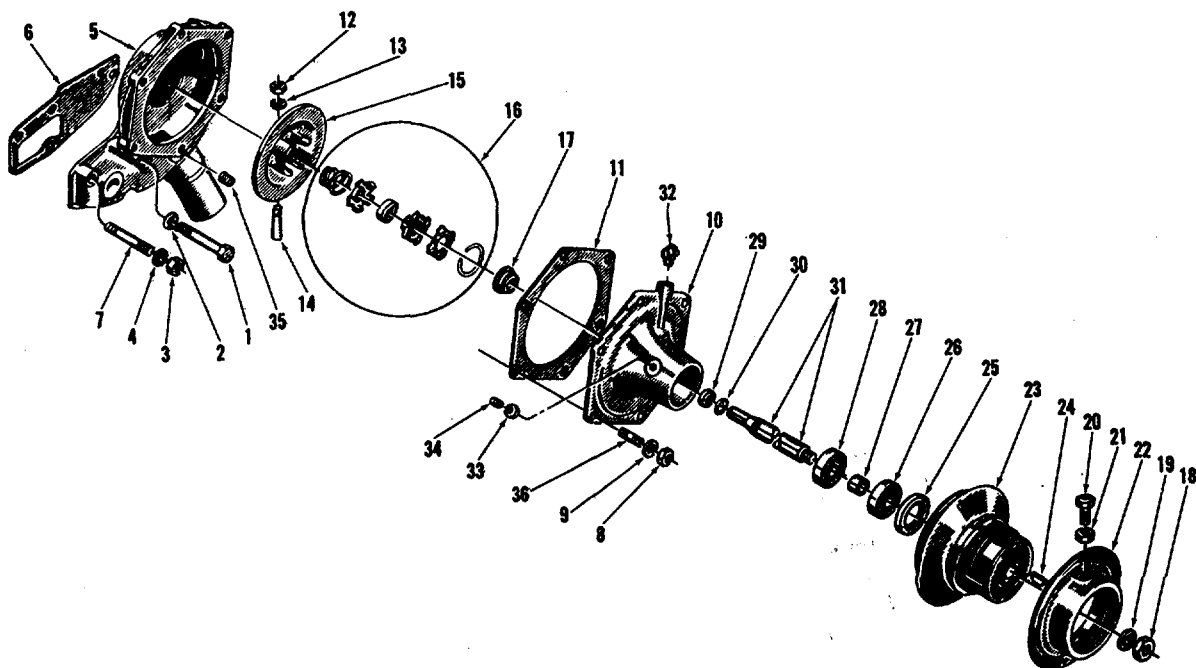

MEC 4320-233-15/49

1 Screw	13 Washer	25 Dust seal
2 Lockwasher	14 Pin	26 Bearing
3 Nut	15 Impeller	27 Spacer
4 Lockwasher	16 Seal assembly	28 Bearing
5 Body	17 Spacer	29 Retainer
6 Gasket	18 Nut	30 Ring
7 Stud	19 Washer	31 Shaft
8 Nut	20 Screw	32 Fitting
9 Lockwasher	21 Nut	33 Nut
10 Support	22 Flange	34 Screw
11 Gasket	23 Hub	35 Plug
12 Nut	24 Key	36 Stud

Figure 65. Water pump, exploded view.

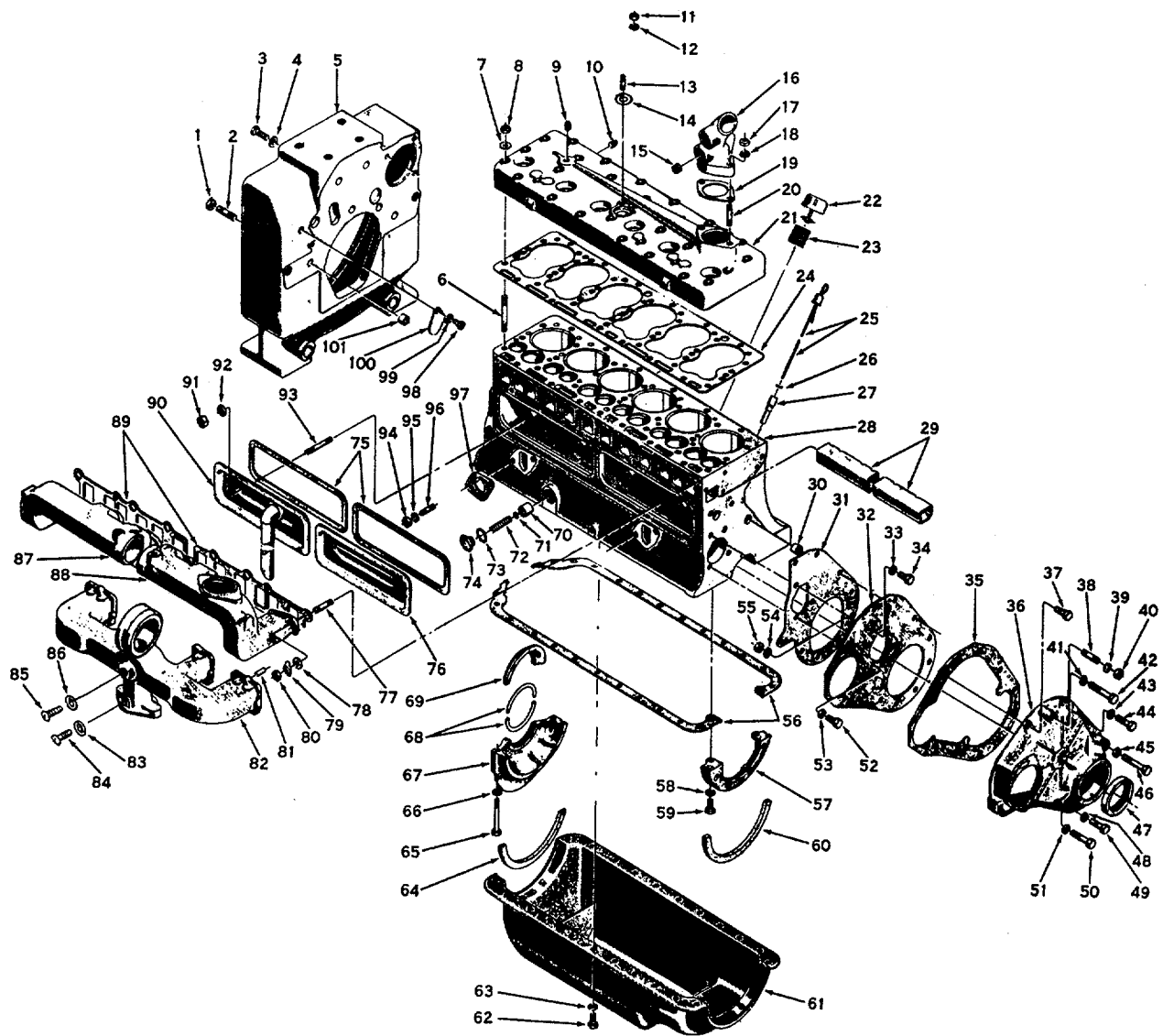

MEC 4320-233-15/50

Figure 56. External engine parts, exploded view.

b. *Cleaning* Clean the radiator as directed in paragraph 76.

c. *Testing and Repair.*

- (1) Place the cap tightly on the radiator and seal the drain hole. Block off the upper hose connections; connect an air line to the lower hose connection with an air pressure gage in the line. Plug the oil cooler ports.
- (2) Submerge the radiator in a tank of water. Open the air line to the radiator and apply a pressure of not more than 8 to 10 psi.

- (3) Watch the radiator for signs of bubbles coming from the core during this pressure test. The pressure cap should rise at approximately this pressure. Shut off the air to the radiator and allow the air to escape until the safety cap seats. Hold the pressure for 5 minutes. If no bubbles appear from the core, the radiator is good. If bubbles appear, mark the origins of the bubbles and remove the radiator from the tank.
- (4) Solder any holes found in the radiator.

## INDEX TO FIGURE 56

1	Nut	35	Gasket	69	Oil guard
2	Stud	36	Cover	70	Valve
3	Screw	37	Screw	71	Washer
4	Lockwasher	38	Stud	72	Spring
5	Flywheel housing	39	Lockwasher	73	Preformed packing
6	Stud	40	Nut	74	Plug
7	Washer	41	Lockwasher	75	Gasket
8	Nut	42	Screw	76	Cover
9	Plug	43	Lockwasher	77	Stud
10	Plug	44	Screw	78	Washer
11	Nut	45	Lockwasher	79	Tabbed washer
12	Lockwasher	46	Screw	80	Nut
13	Stud	47	Seal	81	Dowel
14	Cover plate	48	Lockwasher	82	Manifold
15	Plug	49	Screw	83	Gasket
16	Thermostat housing	50	Screw	84	Plug
17	Nut	51	Lockwasher	85	Plug
18	Lockwasher	52	Screw	86	Gasket
19	Gasket	53	Lockwasher	87	Manifold half
20	Stud	54	Lockwasher	88	Manifold half
21	Head	55	Nut	89	Gasket
22	Oil filler plug	56	Gasket	90	Cover
23	Nipple	57	Filler block	91	Nut
24	Gasket	58	Lockwasher	92	Gasket
25	Oil level gage	59	Screw	93	Stud
26	Felt	60	Seal	94	Nut
27	Support	61	Oil pan	95	Lockwasher
28	Block	62	Screw	96	Stud
29	Tube assembly	63	Lockwasher	97	Gasket
30	Sleeve dowel	64	Seal	98	Screw
31	Gasket	65	Screw	99	Lockwasher
32	Plate	66	Lockwasher	100	Cover
33	Lockwasher	67	Filler block	101	Sleeve dowel
34	Screw	68	Seal		

(5) Solder all tubing connections that leak under pressure.

d. *Installation* Installation of the radiator is the reverse of the removal procedure described in a above.

### 113. Water Pump Repair

(fig. 55)

a. *Removal* Remove the water pump (para 7a).

b. *Disassembly* Disassemble the water pump in order of the index numbers assigned to figure 55. Observe the following special instructions:

- (1) Press the assembled shaft (31)-and bearings (26 and 28) from the support (10).
- (2) Press the bearings from the shaft.

#### Caution

**Apply pressure to the inner bearing races only when removing the bearings from the shaft.**

c. *Cleaning and Inspection.*

- (1) Clean all parts except bearings with an approved cleaning solvent; dry with clean, dry compressed air.

(2) Clean, lubricate, and inspect the bearings as directed in paragraph 106c.

(3) Inspect the seal (16) for defects; inspect the seal spring for deformation or loss of tension. Replace seal if any part is defective.

(4) Inspect all parts for cracks, breaks, wear, stripped threads, or other damage; replace if damaged.

d. *Assembly* Assemble the water pump in the reverse order of disassembly. Observe the following special instructions.

- (1) Press the bearings (26 and 28) onto the shaft (31).
- (2) Press the assembled shaft and bearings into the support (10). Press the dust seal (25) into the support.

e. *Installation* Install the water pump (para 7a).

## Section VI. ENGINE OVERHAUL

### 114. Engine

a. *Description and Function* The engine is a six-cylinder, four-cycle, water-cooled, valve-in-block, pressure-lubricated gasoline engine. It is mounted in the pumping unit with the cooling fan facing the side opposite the pump. The engine is secured to the frame at front and rear and is enclosed by side, top, front, and rear panels which have access doors.

#### b. Removal

- (1) Remove the assembled engine, stub shaft, and dash (para 102).
- (2) Remove the stub shaft and drive (para 103a).
- (3) Remove the dash (para 104).

#### c. Installation

- (1) Install the dash (para 104).
- (2) Install the stub shaft and drive (para 103)
- (3) Install the assembled engine, stub shaft, and dash (para 102).

### 115. Cylinder Head

#### a. Removal (fig. 56).

- (1) Drain coolant from the radiator and engine.
- (2) Remove the spark plugs from the cylinder head (para 7b).
- (3) Remove the two nuts (17) and lockwashers (18) that secure the thermostat housing (16)

to the cylinder head (21); remove the thermostat housing, thermostat, and gasket (19).

- (4) Remove the 33 nuts (8) and washers (7) that secure the cylinder head (21) to the block (28); remove the cylinder head and gasket (24).

#### b. Cleaning and Inspection.

- (1) Wash the cylinder head in an approved cleaning solvent; dry with clean, dry, compressed air.
- (2) Carefully scrape or wire-brush all carbon deposits from the cylinder head, cylinder block, valves, and the top of the pistons. Make sure that all loose carbon is removed to prevent it from getting into the water passages and engine oil.
- (3) Inspect the cylinder head for cracks, breaks, and warpage. Check the flatness of the cylinder head with a straight edge and feeler gage in three positions lengthwise and five positions crosswise (fig. 57). The maximum permissible warpage is 0.004 inch

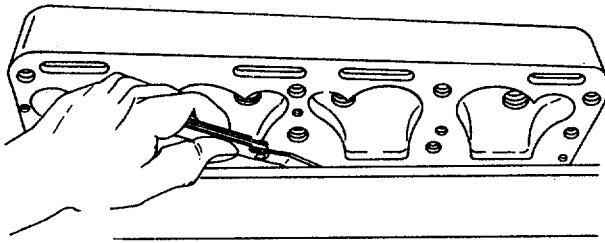

MEC 4320-223-15/91

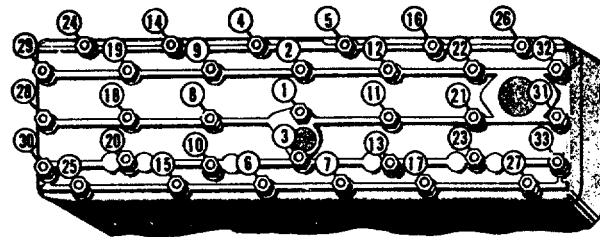

MEC 4320-223-15/92

Figure 57. Checking cylinder head flatness Figure 58. Cylinder head nut tightening sequence.

1 Camshaft	16 Gear	31 Cover
2 Valve	17 Key	32 Gasket
3 Valve seat	18 Washer	33 Retaining ring
4 Guide	19 Nut	34 Driver gear
5 Spring	20 Bearing	35 Key
6 Spring retaining seat	21 Bearing	36 Drive shaft
7 Spring retaining locks	22 Stud	37 Body
8 Cap	23 Lockwasher	38 Bearing
9 Tappet screw	24 Nut	39 Pin
10 Tappet nut	25 Stud	40 Drive gear
11 Tappet body	26 Idler gear	41 Bearing
12 Tappet guide	27 Float assembly	42 Bearing
13 Plate	28 Cotter pin	43 Bearing
14 Lockwasher	29 Screw	44 Bearing
15 Screw	30 Lockwasher	

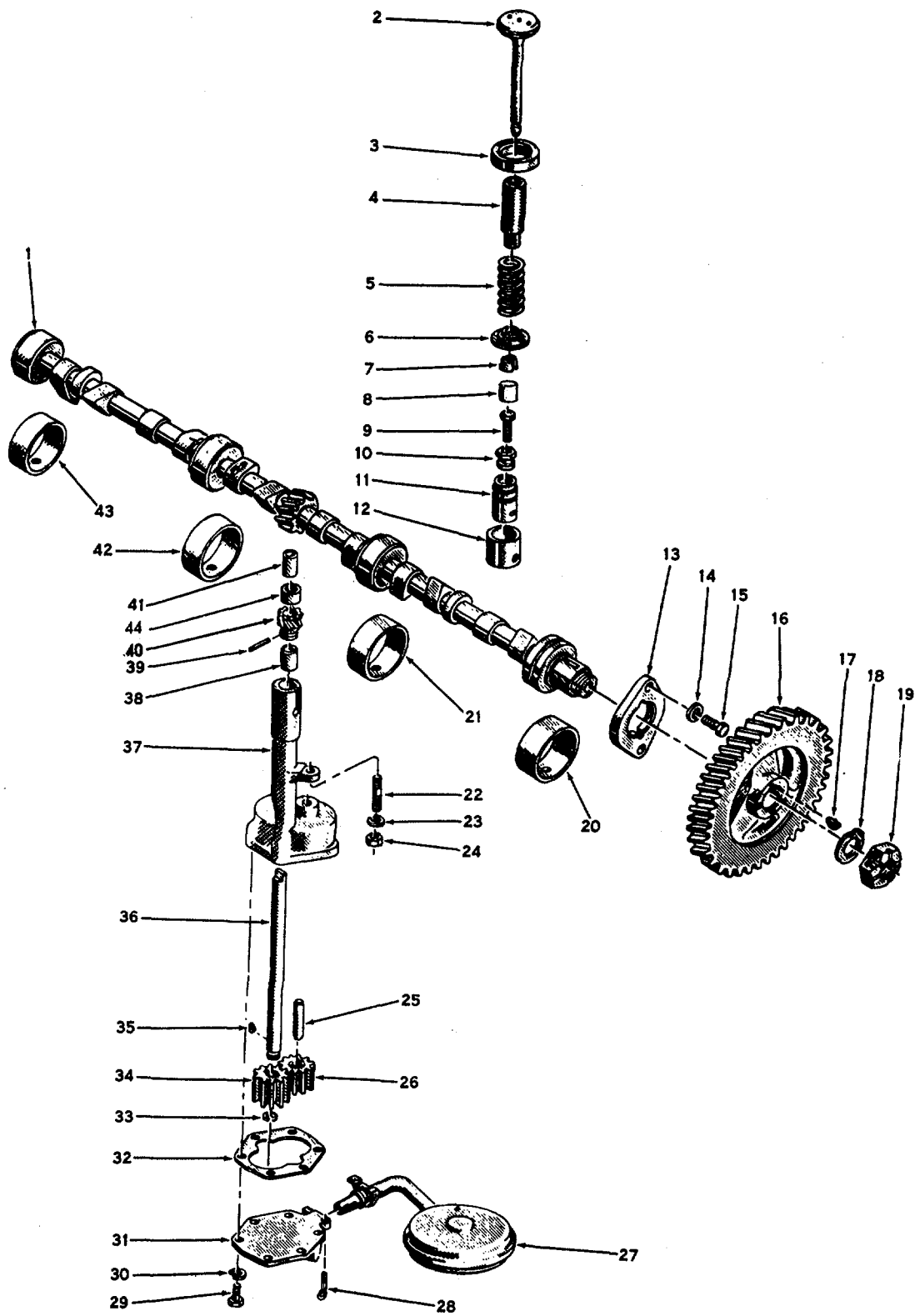

MEC 4320-233-15/53

Figure 59. Valves, camshaft, and oil pump, exploded view.



low in the center lengthwise, gradually decreasing toward the ends, or 0.003 inch crosswise in localized low spots. Replace a cracked, broken, or warped cylinder head.

c. *Installation.*

- (1) Position a new cylinder head gasket (24, fig. 50) and cylinder head (21) on the block (28); secure with the cylinder head nuts (8) and washers (7). Tighten the nuts a little at a time and in the sequence indicated in figure 58. Continue tightening in that rotation until all cylinder head nuts are tightened to 70 to 75 foot-pounds torque.
- (2) Position the thermostat housing (16, fig. 56) and gasket (19) on the cylinder head. Secure with two nuts (17) and lockwashers (18).
- (3) Install the spark plugs in the cylinder head.
- (4) Fill the coolant system.

**116. Valve and Valve Tappets**

a. *Removal (fig. 59).*

- (1) Remove the cylinder head (para 115).
- (2) Remove the valve chamber cover (para 83).
- (3) Using a spring lifter, compress the valve spring (5) at each valve (2) and remove the spring retaining locks (7) from each valve that is in the closed position. Rotate the engine crankshaft to close the remaining valves and remove the remaining locks.
- (4) Lift each valve from the top of the block. Place them in order in a rack to assure that each will be reassembled in the same valve guide from which it was removed.
- (5) Remove the valve stem caps (8). Remove the valve tappet assemblies (9, 10, and 11).
- (6) Do not remove the valve guides (4) or valve seats (3) unless inspection indicates that they are faulty.

b. *Cleaning, Inspection, and Repair.*

- (1) Clean the valves, valve springs, valve tappet assemblies, and valve stem caps with an approved cleaning solvent; dry thoroughly. Remove carbon deposits with a wire brush.
- (2) Clean the valve guides installed in the block with a valve guide cleaner or wire brush. Remove all lacquer and other deposits.
- (3) Clean the valve seats with a wire brush.

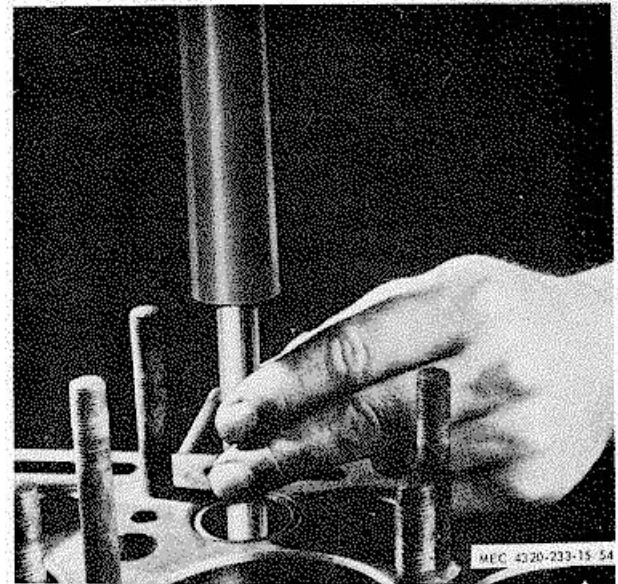

**Figure 60. Removing valve guides.**

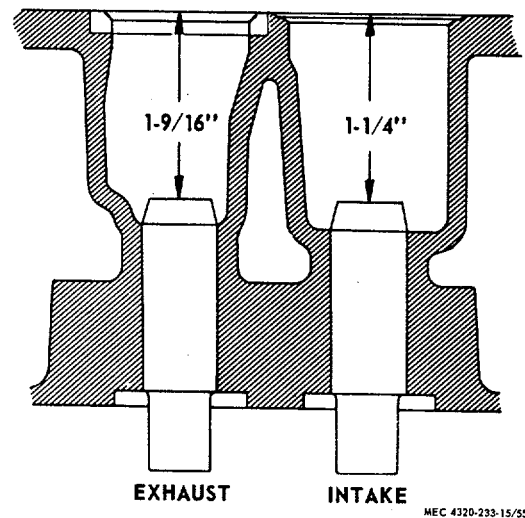

**Figure 61. Valve guide location.**

- (4) Inspect the valves for cracks, bent stems, distortion, and wear. If the valves are not seriously damaged, regrind them. After grinding, the valve head thickness must be at least 50 percent of the thickness of a new valve. Replace the valves if they are ground to less than this amount. Check the reground valves on V-blocks with an indicator. The contact face must be true with the stem to within 0.002 inch. Repeat the refacing operation if necessary.

- (5) Check for loose or worn valve guides. Check the internal diameter of the valve guide with a telescope gage and a micrometer. Replace guides that are worn to a bell-mouthed shape or guides that have a maximum diameter of more than 0.4082 inch.
- (6) If the valve guides are worn or damaged, drive out the guides from the combustion chamber side, using a driver that is slightly smaller than the external diameter of the guide (fig. 60). With the driver, drive in new guides from the combustion chamber side. When properly seated, intake valve guide tops will be 14 inches from the top of the block and exhaust valve guide tops will be 1916 inches from the top of the block (fig. 61).

**Caution**

**Do not attempt to ream the valve guides after seating them. Guides are prereamed and coated. Further reaming will remove the coating.**

- (7) Check the exhaust valve seat inserts for cracks or loose mounting. Pull out faulty valve seats (fig. 62). Replace valve seats with new 0.010-inch oversized valve seats. Counterbore the valve seats to a diameter of 1.688 to 1.687 inches. This will provide a 0.003- to 0.005-inch press fit. Counterbore deeply enough so that the boring tool will clean up the bottom of the bore to assure proper heat conduction from the valve insert. Chill the valve seats in dry ice for 20 minutes. Install the valve seat in place with a piloted driver using an

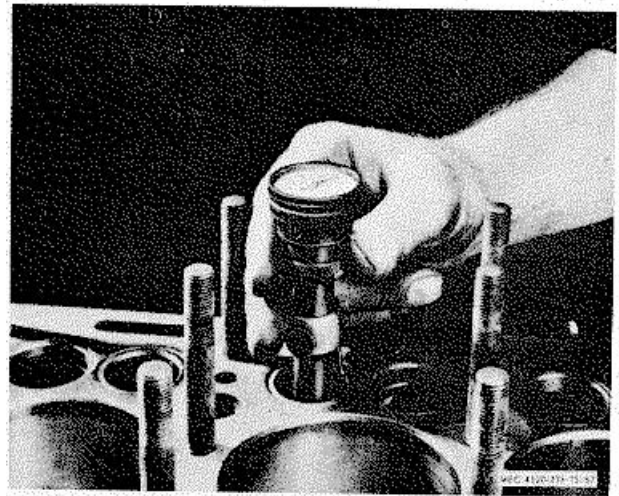

**Figure 63. Checking valve seat for runout.**

arbor press or by applying light blows with a hammer until the valve seat is resting against the bottom of the bore. Roll or peen the valve seat in place.

- (8) Check the valve springs for cracks and distortion. Test compression strength with a spring tester. Compression strength must be as follows:

Length	Load (minimum)
1 7/8 in. (valve closed).....	52 pounds
1.521 in. (valve open).....	103 pounds

- (9) Grind the valve seats. The seat angle of the intake valves is 30°. The seat angle of the exhaust valve is 45°. Use a dial indicator (fig. 63) to check the valve seat

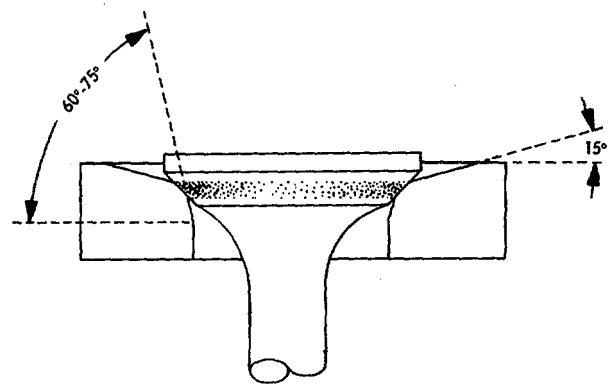

MEC 4320-233-15/58

**Figure 64. Narrowing valve seat.**

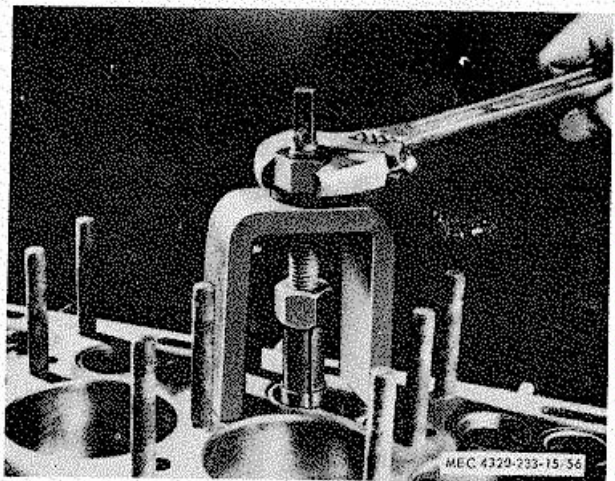

**Figure 62. Pulling valve seat insert.**

for runout. The total indicator reading must not exceed 0.002 inch. Clean the valve seat and surrounding area thoroughly after grinding.

- (10) After the valves and seats have been refaced and reground, coat the seat lightly with Prussian blue and drop the valve into place, oscillating it slightly to transfer the blue pattern to the valve face. This should show a contact width of 1/16 to 3/32 inch, and should fall well within the width of the valve face, leaving at least 1/64 inch on either side of the contact area. If the contact area is greater than 3/32 inch, narrow the contact area by grinding the outside diameter of seat with a 15° stone or by grinding the inside diameter of the seat with a 60° or 75° stone (fig. 58). After the seat area is corrected, touch the seat lightly with the original grinding stone to remove the burred or feathered edge.
- (11) Inspect the spring retainer seats, spring retainer locks, valve stem caps, and valve tappet assemblies for cracks, scoring, overheating, and wear. Replace damaged parts.

*c. Installation (fig. 59).*

- (1) Position the valve tappet assemblies (9, 10, and 11) in the engine block.
- (2) Assemble the valves (2), valve springs (5), spring retaining seats (6), spring retaining locks (7), and valve stem caps (8). Compress the valve springs with a spring compressor to install the spring retaining locks. Turn the engine crankshaft as necessary to allow each valve to move to the closed position before attempting to install the valve parts. Make sure each valve is installed in the guide from which it was removed.
- (3) Temporarily set valve tappet clearance (para 83).
- (4) Install the cylinder head (para 115c).
- (5) Operate the engine until it reaches operating temperature. Adjust valve tappet clearance (para 83).

## **117. Oil Pan and Filler Blocks**

*a. Removal (fig. 56).*

- (1) Remove the engine (para 114b).
- (2) Remove the 22 screws (62) and lock washers (63) that secure the oil pan (61) to the block (28); remove the oil pan and gaskets (56).

- (3) Remove the two screws (59) and lockwashers (58) that secure the filler block (57) to the block; remove the screws (49 and 50) and lockwashers (48 and 51) that secure the filler block to the front end cover; remove the filler block and seal (60).

- (4) Remove the two screws (65) and lockwashers (66) that secure the filler block (67) to the block; remove the filler block and seals (64 and 68).

*b. Cleaning and Inspection.*

- (1) Clean the oil pan and filler blocks in an approved cleaning solvent. Dry with clean, dry, compressed air.
- (2) Inspect the oil pan, oil guard, and filler blocks for cracks, damaged threads, distortion, damaged sealing surfaces, or other defects.

*c. Installation.*

- (1) Install the neoprene seal (64, fig. 56) on the rear filler block (67) by placing a drop of nonhardening cement in the middle of the seal and pressing the seal into the groove in the filler block in the same manner as for the front filler block (fig. 65).
- (2) Install the ring seal (68, fig. 56) in the rear filler block as follows:
  - (a) Flatten the seal in a vise or similar device until the seal fits into the groove in the filler block.
  - (b) Roll the seal into the filler block groove with a round object.
  - (c) Trim the seal ends flush with the filler block.
- (3) Lubricate the seals with engine oil. Install the assembled filler block and seals on the engine block; secure with the screws (65) and lockwashers (66).
- (4) Install the neoprene seal (60) on the front filler block (57) by placing a drop of nonhardening cement on the middle of the seal and pressing the seal into the groove in the filler block (fig. 65).
- (5) Install the assembled gasket and filler block on the engine block; secure with the screws (59, 50, and 49, fig. 56) and lockwashers (58, 51, and 48).
- (6) Position the gaskets (56) on the oil pan (61). Install the oil pan and gaskets on the engine block; secure with the 22 screws (62) and

TAGO 0358A

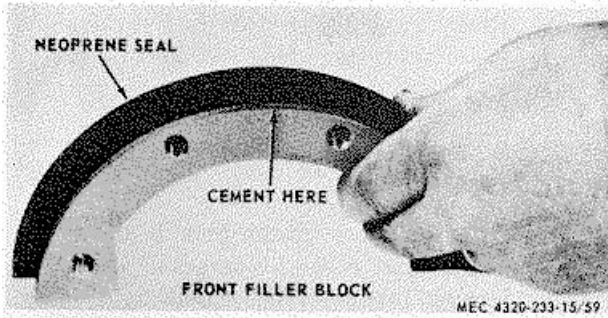

**Figure 65. Installing neoprene seal in front filler block.**

lockwashers (63). Tighten the screws to 12 to 16 footpounds torque.

- (7) Install the engine (para 114c).

### 118. Oil Pump

#### a. Removal (fig. 59).

- (1) Remove the engine (para 114).
- (2) Remove the oil pan (para 117).
- (3) Remove the nut (24) and lockwasher (23) that secure the oil pump to the center bearing cap; remove the oil pump.

#### b. Disassembly (fig. 59).

- (1) Remove the cotter pin (28) that secures the float assembly (27) to the oil pump cover (31); remove the float.
- (2) Remove the screws (29) and lockwashers (30) that secure the cover (31) to the body; remove the cover, gasket (32), and idler gear (26).
- (3) Remove the pin (39) that secures the drive gear (40) to the drive shaft (36); remove the gear from the shaft. Remove the assembled driver gear (34) and drive shaft from the pump body.
- (4) Remove the retaining ring (33) from the lower end of the drive shaft; remove the driver gear and key (35) from the drive shaft.

#### c. Cleaning and Inspection (fig. 59).

- (1) Thoroughly clean all parts with an approved cleaning solvent; dry with clean, dry, compressed air.
- (2) Check the fit of the drive shaft (36) in the bearing (38) in the top of the oil pump body (37) and in the bearing (41) in the crankcase; remove the bearings and press in new parts if the old ones are loose or worn.

- (3) Check the fit of the idler gear (26) and the stud (25); press the stud from the pump body and press in a new stud if the old one is worn, or if the idler gear has been rubbing the walls of the chamber.
- (4) Examine the screen for enlarged openings, breaks, or blocked openings; clean screen openings or replace.

#### d. Assembly.

- (1) Position the key (35, fig. 59) in the slot in the drive shaft (36). Press the driver gear (34) on the drive shaft far enough to install the retaining ring (33), install the retaining ring and press the gear back against the ring.
- (2) Place the idler gear (26) in position in the pump body (37) and on the stud (25).
- (3) Install the assembled driver gear and shaft in the pump body. Press the drive gear (40) onto the drive shaft, with the pin hole the gear in line with the pin hole in the shaft; install the pin (39) through the gear and shaft.
- (4) Check the clearance of the gears in the pump body (fig. 66); there should be 0.001 to 0.003inch clearance in the chamber. The gears should not contact the chamber walls.
- (5) With the cover gasket (32, fig. 59) in place on the body, there should be 0.0015 to 0.006inch clearance between the gears and the cover (fig. 67). Install the cover (31, fig. 59).
- (6) Install the float assembly (27) on the pump body.

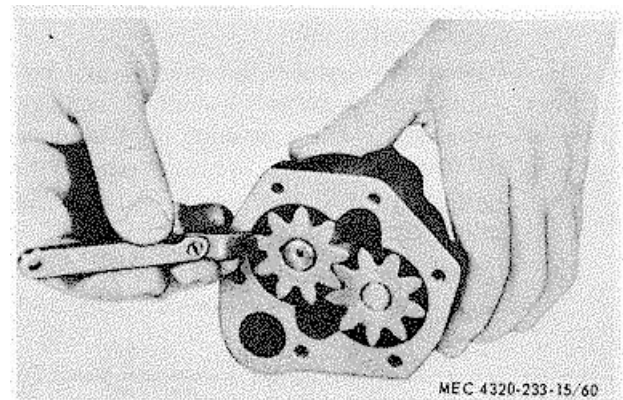

**Figure 66. Checking oil pump gear clearance.**

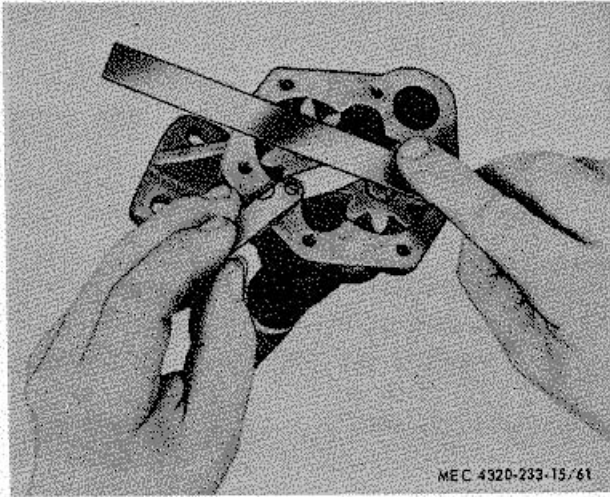

**Figure 67. Checking oil pump end clearance.**

*e. Installation (fig. 59).*

- (1) Position the assembled oil pump on the center bearing cap; secure with the nut (24) and lockwasher (23).
- (2) Install the oil pan (para 117).
- (3) Install the engine (para 114).

**119. Pistons and Connecting Rods**

*a. Removal and Disassembly (fig. 68).*

- (1) Remove the engine (para 114).
- (2) Remove the cylinder head (para 115a).
- (3) Remove the oil pan (para 117).
- (4) Ream the ridge of the top of each cylinder bore with a standard ridge reamer. Blow metal fragments from the cylinder with compressed air.
- (5) Remove the two cotter pins (33) and nuts (32) that secure a connecting rod cap (17) to a connecting rod; remove the cap and sleeve bearing (19).
- (6) Push the assembled piston (13) and connecting rod up through the top of the block.

**Caution**

**While pushing the piston and rod from the block, be very careful the connecting rod does not scratch the cylinder wall.**

- (7) Remove the two retaining rings (15) from the piston; push the piston pin (14) from the piston and rod.

**Note**

**Disassemble the pistons and piston rods in sets and keep the sets together. Also, be sure each piston and piston rod set is reinstalled in the cylinder from which it was removed.**

- (8) Remove the piston rings (10, 11, and 12) from the piston.
  - (9) Remove and disassemble the five remaining piston and connecting rod assemblies.
- b. Cleaning and Inspection.*
- (1) Clean all parts in an approved cleaning solvent; dry with clean, dry, compressed air.
  - (2) Inspect pistons, piston pins, bearings, and connecting rods for cracks, distortion, scoring, pitting, or other defects.
  - (3) Replace piston rings and damaged or defective parts.
- c. Repair and Assembly.*
- (1) Check piston fit using a piece of 0.005-inch feeler stock cut  $\frac{1}{2}$  inch wide. Dress the edges of the feeler stock with a stone to remove burrs and feathered edges. The block and pistons must be at room temperature when piston fit is tested. Position the feeler stock midway between the piston pin bosses. With the piston and feeler stock inserted about 2 inches into the block, the feeler stock must pull from the block with 5 to 10 pounds pull. If the feeler stock does not offer enough resistance, perform the same test with a new standard size piston. If sufficient resistance still is not obtained, rebore the cylinders (para 122) and install oversize pistons.
  - (2) If new pistons (13, fig. 68) and piston pins (14) are being used, press a new sleeve bearing (16) into each connecting rod (17). Ream and hone the sleeve bearings to 1.1097- to 1.1095-inch diameter.
  - (3) If the pistons and pins are not being replaced, check the clearance between the piston pins and the sleeve bearings. Clearance must be between 0.0002 and 0.0006 inch. If clearance is not within this tolerance, press new sleeve bearings into the connecting rods and ream and hone to provide the proper clearance. After honing, 75 percent of the sleeve bearing surface must contact the piston pin.
  - (4) When pins, bushings, and pistons of the proper size have been found, assemble the pistons to the connecting rods as follows:
    - (a) Heat the pistons and connecting rods in an oven or in water to a minimum of 160° F.

TAGO 6358-A

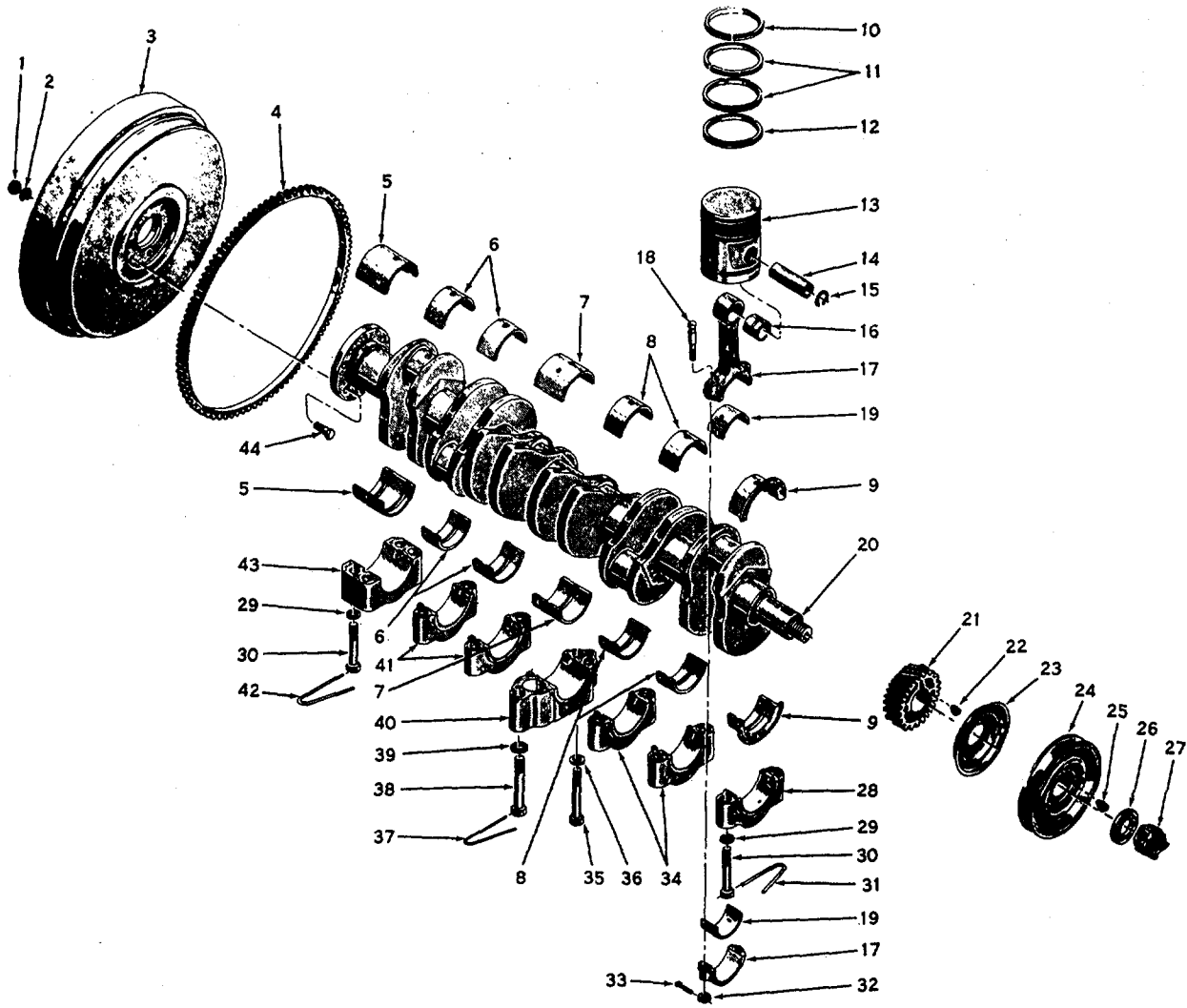

MEC 4320-233-15/62

- |                   |                           |                |
|-------------------|---------------------------|----------------|
| 1 Nut             | 16 Sleeve bearing         | 31 Lock wire   |
| 2 Lockwasher      | 17 Connecting rod and cap | 32 Nut         |
| 3 Flywheel        | 18 Bolt                   | 33 Cotter pin  |
| 4 Ring gear       | 19 Bearing                | 34 Bearing cap |
| 5 Bearing         | 20 Crankshaft             | 35 Screw       |
| 6 Bearing         | 21 Gear                   | 36 Washer      |
| 7 Bearing         | 22 Key                    | 37 Lock wire   |
| 8 Bearing         | 23 Oil thrower            | 38 Screw       |
| 9 Bearing         | 24 Pulley                 | 39 Washer      |
| 10 Piston ring    | 25 Key                    | 40 Bearing cap |
| 11 Piston ring    | 26 Washer                 | 41 Bearing cap |
| 12 Piston ring    | 27 Starting jaw           | 42 Lock wire   |
| 13 Piston         | 28 Bearing cap            | 43 Bearing cap |
| 14 Piston pin     | 29 Washer                 | 44 Screw       |
| 15 Retaining ring | 30 Screw                  |                |

Figure 68. Crankshaft, pistons, and connecting rods, exploded view.

- (b) Position a connecting rod in its piston. Install the piston pin; secure with the retaining rings (15).
- (5) Slide the piston rings (10, 11, and 12) squarely into the cylinders in which they will be used. Check the ring gap with feeler stock. Ring gap must be within the following tolerances:
  - Top ring.....0.008 in. to 0.013 in.
  - Middle rings.....0.011 in. to 0.016 in.
  - Bottom ring.....0.010 in. to 0.020 in.
- (6) If the gap is too small, file the rings to provide a proper gap.
- (7) Install the piston rings on the piston with a standard ring expander.
- (8) Assemble the remaining pistons, connecting rods, and piston rings.
- (9) Install the assembled pistons and connecting rods in the block using a ring compressor to compress the piston rings. Lubricate the pistons and cylinder walls with engine oil before installing the pistons. Wrap the bottom end of the connecting rods with a cloth to prevent damage to the cylinder walls during installation.
- (10) Check the crank pin bearing journal-to-connecting rod bearing clearance with plastigage as follows:
  - (a) Place a piece of plastigage near the oil hole of the bearing cap.
  - (b) Position the cap on the connecting rod and secure with the two nuts and lockwashers. Tighten the nuts (32) to 70 to 75 foot-pounds torque.
  - (c) Remove the bearing and bearing cap. Check the bearing journal-to-bearing clearance using plastigage (fig. 63). If clearance is not between 0.0007 and 0.0025 inch, replace the connecting rod bearings and recheck the clearance. If clearance is still not within tolerance, replace the crankshaft.
- (11) As an alternate method of checking crank pin bearing journal-to-connecting rod bearing clearance, install a piece of 0.0025-inch thick feeler stock between the bearing and journal. Lubricate the bearing journal with SAE 10 engine oil. Install the connecting rod cap. Tighten the connecting rod cap nuts (32, fig. 68) to 70 to 75 foot-pounds torque. Try to slide the connecting rod alternately toward the front and rear of the engine. If clearance is within tolerance, a

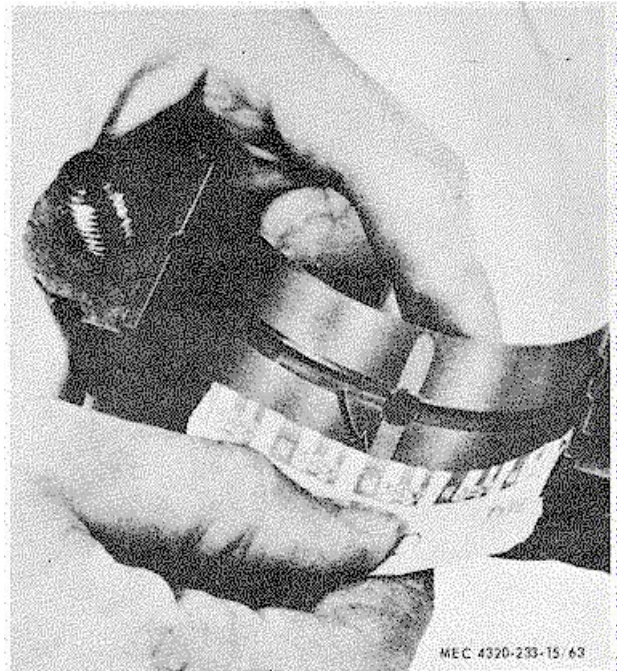

**Figure 69. Checking bearing clearance using plastigage.**

definite drag will be felt. If clearance is not within tolerance, replace the connecting rod bearings and recheck the clearance. If clearance is still not within tolerance, replace the crankshaft.

- (12) Lubricate the crank pin bearing journals and the sleeve bearings with engine oil. Install a cap (17) on its connecting rod and on the crank pin bearing journal; secure with the two bolts (18) and nuts (32). Tighten the nuts to 70 to 75 foot-pounds torque. Install the cotter pins (33).
- (13) Secure the remaining connecting rods to the crank pins bearing journals.
- (14) Install the oil pan (para 117).
- (15) Install the cylinder head (para 115).
- (16) Install the engine (para 114).

## 120. Flywheel and Flywheel Housing

### a. Removal.

- (1) Remove the engine (para 114).
- (2) Remove the six nuts (1, fig. 68) and lockwashers (2) that secure the flywheel (3) to the crankshaft (20); remove the flywheel.
- (3) Remove the four screws (3, fig. 56), lockwashers (4), and two nuts (1) that secure the flywheel housing (6) to the block (28); remove the flywheel housing.

b. *Cleaning and Inspection.*

- (1) Clean all parts in an approved dry cleaning solvent. Dry with clean, dry, compressed air.
- (2) Inspect the flywheel housing for cracks, damaged sealing surfaces, or other defects.
- (3) Inspect the flywheel for damaged teeth, cracks, distortion, or other defects.
- (4) Replace damaged or defective parts.

c. *Installation.*

- (1) Position the flywheel housing (5, fig. 56) on the block (28); secure with the four screws (3), lockwashers (4), and two nuts (1).
- (2) If the teeth on the flywheel ring gear (4, fig. 68) are damaged, replace the ring gear as follows:
  - (a) Cut the ring gear with a torch or hacksaw and remove the ring gear from the flywheel (3).

**Caution:**

**When cutting the ring gear, be extremely careful not to damage the flywheel.**

- (b) Heat the replacement ring gear in an oven and cool the flywheel in water or a refrigerator.

- (c) Position the replacement ring gear on the flywheel. As the ring gear and flywheel approach the same temperature,

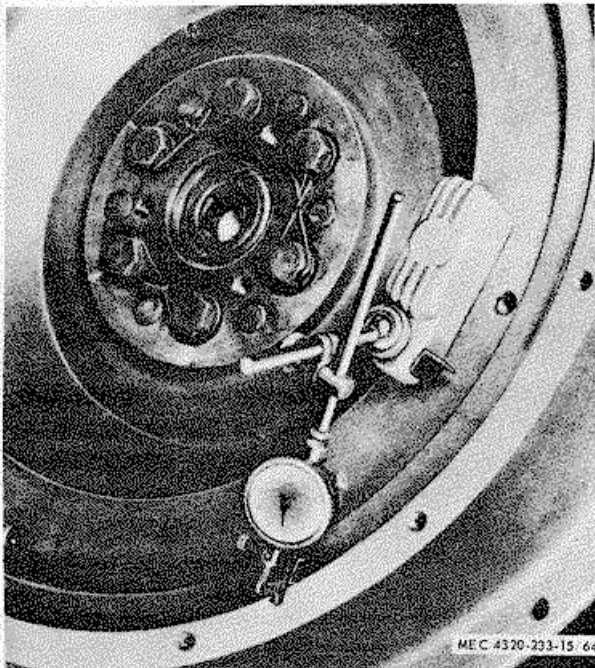

**Figure 70. Checking flywheel housing runout.**

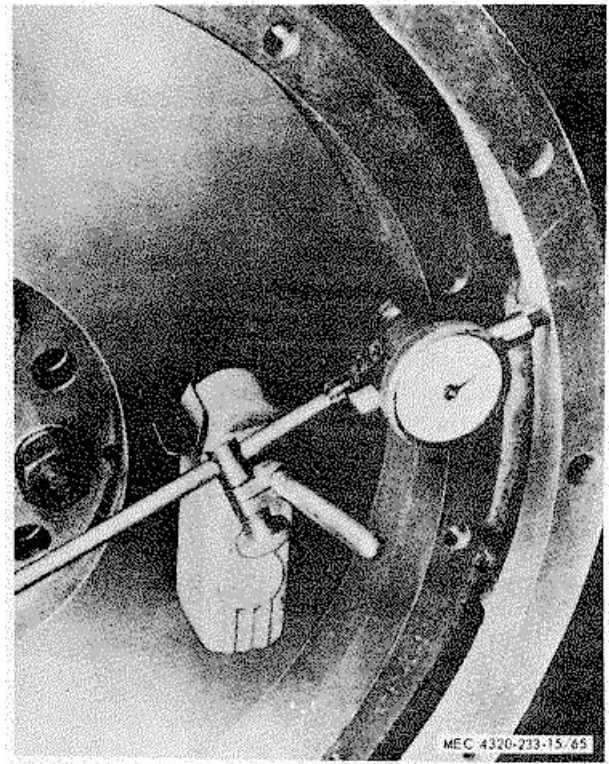

**Figure 71. Checking flywheel housing eccentricity.**

the ring gear will contract to a very tight fit on the flywheel.

- (3) Position the assembled flywheel and ring gear on the crankshaft (20, fig. 68); secure with six screws (44), lockwashers (2), and nuts (1). Tighten the nuts to 85 to 95 foot-pounds torque.
- (4) Check flywheel runout by mounting a dial indicator on the flywheel housing with the indicating tip against the face of the flywheel. Rotate the crankshaft through one full revolution. Hold pressure against the flywheel to eliminate crankshaft end play. If flywheel runout exceeds 0.008 inch, remove the flywheel and clean the crankshaft flange and flywheel seat. Install the flywheel and recheck runout. If runout still exceeds 0.008 inch, replace the flywheel.
- (5) Check flywheel eccentricity by mounting a dial indicator on the flywheel housing with the tip against the inside of the counterbore of the flywheel. Rotate the crankshaft through one revolution. If flywheel eccentricity exceeds 0.008 inch,



loosen and retighten the flywheel mounting bolts and recheck eccentricity. If eccentricity still exceeds 0.008 inch, replace the flywheel.

- (6) Check runout of the flywheel housing face by mounting a dial indicator on the flywheel with the indicator tip against the inside of the face of the flywheel housing (fig. 64). Rotate the crankshaft through one revolution. Hold pressure against the flywheel to eliminate end play. If runout exceeds 0.008 inch, clean the mounting surfaces of the flywheel housing and the block. Recheck flywheel housing runout. If the runout is still not within limits, replace the flywheel housing.
- (7) Check eccentricity of the flywheel housing bore by mounting a dial indicator (fig. 71) on the flywheel with the indicator tip against the inside of the flange of the flywheel housing. Rotate the engine through one revolution. If housing bore eccentricity exceeds 0.008 inch, loosen the flywheel housing mounting bolts and tap the housing into its proper position with a soft hammer. Tighten the bolts and recheck housing bore eccentricity. If the housing can not be brought into true position, replace the housing.
- (8) Install the engine (para 114c)

## 121. Crankshaft, Crankshaft Bearings, and Camshaft

### a. Removal.

- (1) Remove the engine (para 114b).
- (2) Remove the cylinder head (para 115a).
- (3) Remove the oil pan and filler blocks (para 117a).
- (4) Remove the oil pump (para 118a).
- (5) Remove the flywheel and flywheel housing (para 120a).
- (6) Remove the starting jaw (27, fig. 62) and washer (26) that secure the pulley (24) to the crankshaft (20). Pull the pulley from the crankshaft. Remove the key (25) from the crankshaft.
- (7) Remove the screws (37, 42, 44, and 46, fig. 56) lockwashers (41, 43, and 45), nut (40), and lockwasher (39) that secure the front end cover (36) to the block (28); remove the front end cover and gasket (35).
- (8) Press the seal (47) from the front end cover.

- (9) Remove the two cotter pins (33, fig. 68) and nuts (32) that secure each cap (17) to its connecting rod; remove the caps and sleeve bearings (19). Take care that each connecting rod cap is identified with the rod from which it was removed. Do not interchange rods and bearings.

*Note.* d, below, contains instructions for main bearing replacement without removing the crankshaft.

- (10) Remove the 10 screws (30) and washers (29) that secure the five bearing caps (28, 34, and 41) to the block; remove the caps.
- (11) Remove the two screws (35 and 38) and washers (36 and 39) that secure the bearing cap (40) to the block; remove the cap.
- (12) Remove the four screws (30) and washers (29) that secure the bearing cap (43) to the block; remove the cap.
- (13) Remove the sleeve bearings (5 through 9) from the bearing caps.
- (14) Lift the crankshaft (20) from the block.
- (15) Remove the sleeve bearings (5 through 9) from the block.
- (16) Remove the oil guard (69, fig. 56) from the block. Remove the seal (68) from the guard.
- (17) Remove the valves (para 116a).
- (18) Remove the valve tappet assemblies (9, 10, and 11, fig. 59). Note the location of each Figure 72. Checking gear clearance.

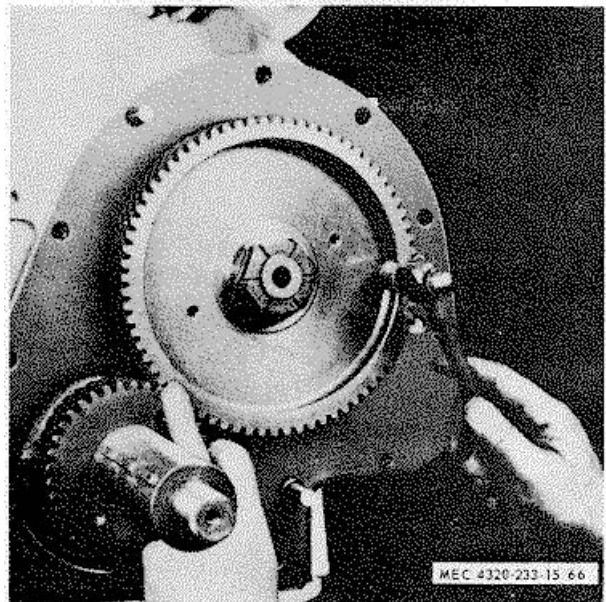

Figure 72. Checking gear clearance

valve tappet assembly so it may be reinstalled in the guide hole from which it was removed.

- (19) Remove the nut (19) and washer (18) that secure the gear (16) to the camshaft (1); pull the gear from the camshaft. Remove the key (17).
- (20) Remove the two screws (15) and lockwashers (14) that secure the thrust plate (13) to the block; remove the plate.
- (21) Pull the camshaft from the block.

*b. Cleaning and Inspection.*

- (1) Clean all metal parts in an approved cleaning solvent. Dry with clean, dry, compressed air. Make sure that the crankshaft oil ports are open by blowing compressed air through each port.
- (2) Inspect the crankshaft for cracks, scored or grooved bearing journals, damaged key slots and bolt holes, or other defects.
- (3) Inspect the camshaft for cracks, **pitting**, worn or scored lobes or bearing journals, damaged threads or key slots, or other defects.

*c. Installation.*

- (1) If the gear (21, fig. 68) is damaged or defective, press the gear from the crankshaft (20). Position the key (22) in the keyway and press a replacement gear onto the crankshaft. When the gear is replaced the camshaft gear (16, fig. 59) must also be replaced.
- (2) Flatten the seal (68, fig. 56) with a vise or similar device; install in the rear oil guard (69). Trim the seal flush with the guard. Install the assembled seal and guard in the block (28). Lubricate the seal with engine oil.
- (3) Position the upper half of the sleeve bearings (5 through 9, fig. 68) in the block. Install the crankshaft (20) in the block. Install the lower half of the sleeve bearings in the bearing caps (28, 34, 40, 41, and 43).
- (4) Check the clearance between the crankshaft bearing journals and bearings with plastigage or as directed in paragraph 119c(10).
- (5) Clearance must be between 0.0015 and 0.0037 inch. If the clearance is not within these limits, replace the bearings and recheck the clearance.
- (6) Check the remaining bearing-to-bearing

journal clearances and replace bearings as necessary.

- (7) An alternate method of checking bearing clearance is as follows:
  - (a) Oil bearing and bearing journal with engine oil.
  - (b) Position a strip of 0.0037-inch feeler gage, 1/2 inch long, on the bearing cap.
  - (c) Install the cap on the block; secure with the screws (30, 35, and 38) and lockwashers. Tighten the screws to 855 to 95 foot-pounds torque.
  - (d) Try to turn the crankshaft by hand. If the crankshaft will not turn or a definite drag is felt, bearing-to-bearing journal clearance is within tolerance.
- (8) After all main bearings have been installed, check crankshaft end play using a dial indicator. If end play is not between 0.003 and 0.008 inch, replace the front sleeve bearing (9).
- (9) Install the camshaft (1, fig. 59) in the block. Check the clearance between the camshaft bearing journals and camshaft bearings (20, 21, 42, and 43) with feeler stock cut in strips 1/4 inch wide. Dress the feeler stock with a stone to eliminate burs or feathered edges. Clearance between the bearings and journals must be between 0.0015 and 0.003 inch.

**Caution: Do not insert the camshaft too far into the block. If the camshaft bumps the expansion plug on the drive end of the engine, an oil leak could result.**
- (10) If clearance exceeds 0.003 inch, remove the camshaft from the block and install new camshaft bearings. The camshaft bearings are presized and do not have to be honed after installation.
- (11) Lubricate the camshaft bearings with engine oil and install the camshaft in the block. Position the thrust plate (13) on the camshaft; secure with the two screws (15) and lockwashers (14).
- (12) Position the backing plate (32, fig. 56) and gasket (31) on the block; secure with the six screws (34 and 52) and lockwashers (33 and 53).
- (13) Position the key (17, fig. 59) on the camshaft. Hold the camshaft toward the front of the engine with a bar inserted into the fuel pump hole. Aline the timing marks on the camshaft and crankshaft gears. Drive

the gear (16) onto the camshaft. Secure with the nut (19) and washer (18). Tighten the nut to 85 to 90 foot-pounds. When properly assembled, the two marked teeth on the camshaft gear must be engaged by the single marked tooth on the crankshaft.

**Caution: Failure to align the timing marks of the crankshaft and camshaft gears will prevent engine operation.**

- (14) Check camshaft end play with a dial indicator. If end play is not between 0.005 and 0.008 inch, remove the camshaft timing gear and replace the thrust plate (13).
- (15) Check the clearance between the camshaft and crankshaft gears as follows:
  - (a) Force the teeth of the gears apart with a screw driver. Attempt to insert a 0.0015-inch feeler gage into the gap between the gears. If the gage will enter, the clearance is excessive.
  - (b) If the gage will not enter, place a finger at the junction of the two gears and tap the camshaft gear with a hammer (fig. 72). If vibrations can be felt in the large gear, the clearance is sufficient.
- (16) If gear clearance is too great or too small, the gears must be replaced. Replace the gears only in sets. Gear sets are available in standard size (marked S), 0.002 and 0.004 inch undersize (marked U), and 0.002 and 0.004 inch oversize (marked O). Install a gear set marked the same as the set removed. Check the clearance as directed in (15) above. If clearance is too great, install the next smaller size gear set. If clearance is insufficient, install the next larger size set.
- (17) Install each valve tappet assembly (9, 10, and 11, fig. 59) in its hole. Check the clearance between the lifter and the bore. If clearance exceeds 0.005 inch, replace the valve tappet assemblies.
- (18) Install the valves (para 116c).
- (19) Install the connecting rod sleeve bearings (19gf 68) in the connecting rods (17) and connecting rod caps. Pull the connecting rods against the crank pins. Install the connecting rod caps on the connecting rods; secure with two nuts (32) and cotter pins (33). Tighten the nuts to 70 to 75 foot-pounds torque.
- (20) Press a new seal (47, fig. 56) into the front

end cover (36). Position the cover and gasket (35) on the block; secure with the screws (37, 42, 44, and 46), nut (40), and lockwashers (39, 41, 43, and 45).

- (21) Install the flywheel and flywheel housing (para 120c).
  - (22) Install the oil pump (para 118e).
  - (23) Install the oil pan and filler blocks (para 117c).
  - (24) Install the cylinder head (para 115c).
  - (25) Install the engine (para 114c).
- d. *Crankshaft Bearing Replacement* Remove and replace the bearings without removing the crankshaft as follows:
- (1) Remove the bearing cap; remove the bearing from the cap.
  - (2) Install a pin with an angular head in the oil hole in the crankshaft bearing journal (fig. 73).
  - (3) Rotate the crankshaft by hand. The pin will force the top bearing half out of its seat.
  - (4) Position the replacement bearing on the crankshaft bearing journal. Rotate the crankshaft by hand. The pin will force the bearing half into position.
  - (5) Install the replacement bearing half in the cap. Install the cap.

## 122. Engine Block

- a. *Removal and Disassembly.*
- (1) Remove the engine (para 114b).
  - (2) Disassemble the engine (para 86a(l) and (4)) and (para 115 through 121)
- b. *Cleaning* Remove dirt and grease deposits from the block with a putty knife. Steam-clean the block. Remove greasy or gummy deposit with a cloth dampened in an approved cleaning solvent.

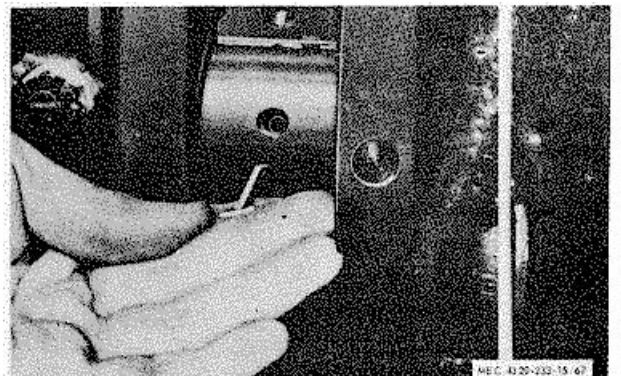

Figure 73. Removing bearing with angular-headed pin.

Clean the oil and water passages in the block with compressed air. Remove varnish deposits with a wire brush.

*c. Inspection.*

- (1) Inspect the block for cracks, damaged sealing surfaces, scored or damaged bearing seats, scored or scratched cylinder walls, damaged threads, loose or damaged studs, corrosion in the water jacket, or other defects.
- (2) Check piston fit in the cylinder bores (para 119c(1)).
- (3) Check cylinder bore wear with an inside micrometer. Measure the cylinder bore at 450 intervals below the travel of the lowest piston ring where the cylinder is not worn. Compare this measurement with a measurement taken about Y inch below the top of the cylinder. The maximum allowable

cylinder wear (the difference between these two measurements) is 0.008 inch.

- (4) Replace the block if it is cracked or defects cannot be repaired. Replace loose or damaged studs. Retap damaged threads. If a proper piston fit cannot be attained (para 119c(1)), the cylinders are scratched or scored, or cylinder wear exceeds 0.008 inch, rebore the cylinders as directed in d below.

*d. Reboring* Rebore the cylinders to 4.020 to 4.022-inch diameter (0.020 in. oversize). If this is not sufficient to eliminate cylinder wear or damage, rebore the cylinders to 4.040 to 4.042-inch diameter (0.040 inch oversize). Maximum allowable overbore is 0.040 inch.

*e. Assembly and Installation.*

- (1) Assemble the engine (para 86c and paras 115 through 121).
- (2) Install the engine (para 114c).

## Section VII. PUMP REPAIR

### 123. General

a. The pump is a centrifugal type with a 6-inch intake and a 6-inch discharge. It is self-priming and has an integral check valve which retains the fluid in the volute when the pump is shut down. The enlarged top of the volute helps to provide rapid self-priming when the pump is started.

b. The drive shaft is mounted in ball bearings supported in the bearing frame. One single row ball bearing and one double row ball bearings are used. The impeller is mounted on the end of the shaft opposite the drive end with the ball bearings supporting the center section of the shaft.

c. A mechanical seal is provided to prevent the fluid being pumped from entering the bearing frame.

### 124. Pump

*a. Removal.* Remove the pump from the pumping unit (para 101a).

*b. Installation.* Install the pump (para 101a).

### 125. Suction Head and Check Valve (fig. 74)

*a. Removal and Disassembly* Remove and disassemble the suction head and check valve in order of index numbers 1 through 19 assigned to figure 74.

*b. Cleaning and Inspection.*

- (1) Clean all metal parts in an approved cleaning solvent; dry with clean, dry, compressed air.

- (2) Clean the check valve parts with soapy water; rinse and wipe dry.
- (3) Inspect the weight and check valve parts for wear, rips, elongated holes, stretching, and other damage. Replace damaged parts.
- (4) Inspect the gaskets (3, 11, 13, and 17) for damage; replace if damaged.
- (5) Inspect all other parts for wear, cracks, breaks, stripped threads, or other damage; replace damaged parts.

*c. Assembly and Installation* Assembly and installation of the suction head and check valve are the reverse of removal and disassembly.

### 126. Discharge Elbow and Lifting Bail

*a. Removal.* Remove the discharge elbow and lifting bail in order of index numbers 20 through 25 assigned to figure 68.

*b. Cleaning and Inspection.*

- (1) Clean all parts in an approved cleaning solvent; dry with clean, dry, compressed air.
- (2) Inspect all parts for wear, cracks, breaks, stripped threads, or other damage; replace damaged parts.

*c. Installation* Installation of the discharge elbow and lifting bail is the reverse of removal.

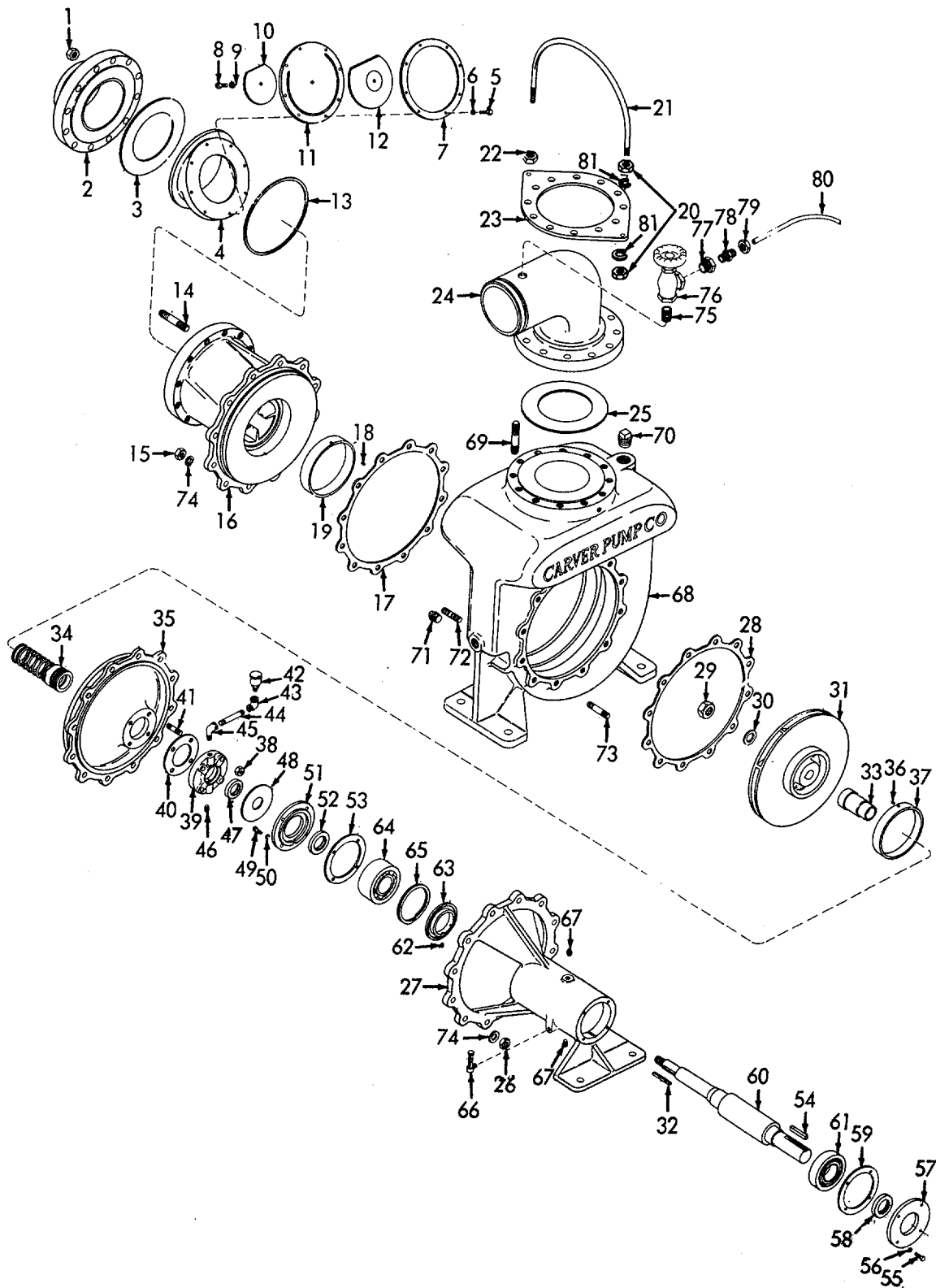

MEC 4320-233-15/68

Figure 74. Pump, exploded view.

## INDEX TO FIGURE 74

1 Nut	28 Gasket	55 Screw
2 Intake nipple	29 Nut	56 Lockwasher
3 Gasket	30 Washer	57 Bearing cap
4 Check valve support	31 Impeller	58 Seal
5 Screw	32 Key	59 Gasket
6 Lockwasher	33 Sleeve	60 Shaft
7 Check valve ring	34 Seal	61 Bearing
8 Screw	35 Seal cover	62 Setscrew
9 Lockwasher	36 Setscrew	63 Slinger
10 Check valve weight	37 Wear ring	64 Bearing
11 Gasket	38 Nut	65 Retaining ring
12 Check valve weight	39 Gland	66 Sight level gage
13 Gasket	40 Gasket	67 Pipe plug
14 Stud	41 Stud	68 Volute
15 Nut	42 Oil cup	69 Stud
16 Suction head	43 Elbow	70 Plug
17 Gasket	44 Nipple	71 Plug
18 Setscrew	45 Elbow	72 Stud
19 Wear ring	46 Plug	73 Stud
20 Nut	47 Seal	74 Lockwasher
21 Lifting bail	48 Slinger	75 Nipple
22 Nut	49 Screw	76 Valve
23 Plate	50 Lockwasher	77 Reducer bushing
24 Discharge elbow	51 Bearing cap	78 Connector
25 Gasket	52 Seal	79 Union nut
26 Nut	53 Gasket	80 Tube
27 Bearing support	54 Key	81 Lockwasher

### 127. Impeller, Shaft, Seal and Bearings (fig. 74)

*a. Removal and Disassembly* Remove and disassemble the impeller, shaft, seal, and bearings in order of index numbers 26 through 67 assigned to figure 74. Observe the following special instructions:

- (1) Press the assembled shaft (60) and bearing (61) out of the coupling end of the bearing support (27). Loosen the setscrew (62) and remove the slinger (63) from the shaft. Press the bearing (61) from the shaft.
- (2) Press the bearing (64) from the bearing frame. Remove the retaining ring (65) from the bearing frame.

*b. Cleaning and Inspection.*

- (1) Clean all metal parts except bearings and seals with an approved cleaning solvent; dry with clean, dry, compressed air.
- (2) Wipe gaskets with a damp cloth.
- (3) Clean seals with a cloth dampened with cleaning solvent. Do not allow solvent to contact rubber or synthetic materials.
- (4) Clean, lubricate, and inspect bearings as directed in paragraph 106c.
- (5) Inspect seal (34) for spring distortion, wear, or defects; replace if defective.

- (6) Inspect all gaskets for damage; replace if damaged.
- (7) Inspect seal (58) for wear or damage; replace if worn or damaged.
- (8) Inspect all other parts for cracks, ~~bars~~, stripped threads, wear, or other damage; replace if damaged.

*c. Assembly and Installation* Assemble and install impeller, shaft, seal, and bearings making sure the shielded portion of the bearings are facing the bearing caps. Observe the following special instructions:

- (1) Press the bearing (64) onto the shaft. Position the slinger (63) on the shaft; secure with the setscrews (62).
- (2) Install the retaining ring (65) in the bearing frame. Press the assembled shaft, slinger, and bearing into the bearing frame until the bearing bottoms on the retaining ring.
- (3) Install the bearing (61) into the bearing frame and onto the shaft. Tighten the screws (49 and 55) that secure the bearing caps (51 and 57) evenly and alternately to make sure the bearings seat squarely without binding.
- (4) Rotate the shaft after assembly to make sure the parts ride freely.

**Section VIII. SKID BASE AND RELATED PARTS**

## 128. General

### a. Description and Function.

- (1) The skid base is composed of steel I-beam side rails heavily braced with I-beam cross members and one tubular cross member at each end. Additional steel channels and plates are provided to mount the components of the pumping unit.
- (2) The skid base is of welded construction with the components attached by bolts and nuts. The fuel tank is mounted between the side rails of the skid base.

### b. Removal.

- (1) Remove the pump (para 101a).
- (2) Remove the engine (para 114b).
- (3) Remove the batteries (para 65c).

### c. Installation.

- (1) Install the engine (para 114c).
- (2) Install the pump (para 101c).
- (3) Install the batteries (para 65c) 129. Repair a. Disassembly. Disassemble the parts from the skid base as required. Refer to figure 75.

### b. Cleaning and Inspection.

- (1) Steam-clean the skid base and battery box parts.
- (2) Flush the fuel tank with an approved cleaning solvent and drain.
- (3) Remove any greasy or gummy deposits with a cloth dampened with an approved cleaning solvent; dry thoroughly.

c. *Assembly.* Assemble the parts removed from the skid base. Refer to figure 75.

---

## INDEX TO FIGURE 75

1	Wingnut	17	Nut	33	Fuel tank
2	Lockwasher	18	Capscrew	34	Pipe plug
3	Battery box cover	19	Engine mounting block	35	Capscrew
4	Wingnut	20	Coupling guard	36	Skid base
5	Lockwasher	21	Capscrew	37	Lockwasher
6	Top frame	22	Lockwasher	38	Nut
7	Capscrew	23	Plug	39	Nut
8	Battery box	24	Elbow	40	Lockwasher
9	Capscrew	25	Screw	41	Nut
10	Battery box base	26	Lockwasher	42	Lockwasher
11	Anchor rod	27	Flange	43	Nut
12	Capscrew	28	Gasket	44	Lockwasher
13	Engine mounting block	29	Tank riser	45	Nipple
14	Capscrew	30	Liquid level gage	46	Coupling
15	Engine mounting block	31	Fuel tank cap	47	Lockwasher
16	Lifting bail	32	Gasket	48	Lockwasher



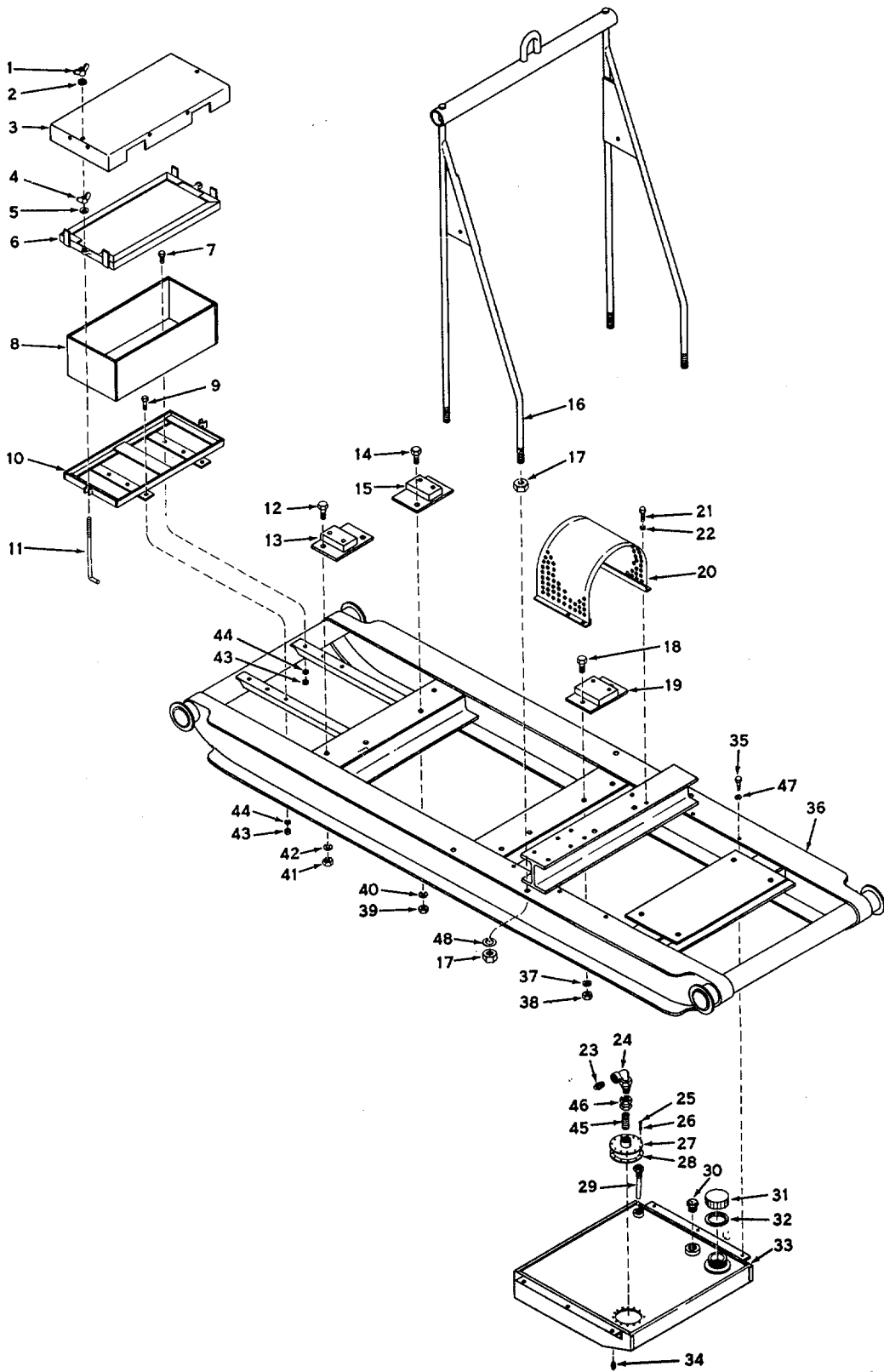

MEC 4320-233-15/69

Figure 75. Skid base and related parts, exploded view.

## APPENDIX I REFERENCES

---

### 1. Dictionaries of Terms and Abbreviations

AR 320-5  
AR 320-50 Dictionary of United States Army Terms.  
Authorized Abbreviations and Brevity Codes.

### 2. Fire Protection

TB 5-4200-200-10  
TM 5-87 Hand Portable Fire Extinguisher Approved for Army Users.  
Repair and Utilities: Fire Protection Equipment and Appliances: Inspections,  
Operations, and Preventive Maintenance.

### 3. Lubrication

LO 5-4320-233-15 Lubrication Order.

### 4. Painting

TM 9-213 Painting Instructions for Field Use.

### 5. Preventive Maintenance

AR 750-5 Organization, Policies and Responsibilities for Maintenance Operation.

TB ENG 347 Winterization Techniques for Engineer Equipment.

TM 5-764 Electric Motor and Generator Repair.

TM 9-207 Operation and Maintenance of Army Materiel in Extreme Cold Weather (0 to  
- 65 F. ).

TM 9-6140-200-15 Operation and Organizational, Field and Depot Maintenance: Storage Batteries,  
Lead-Acid Type.

TM 38-750 Army Equipment Record Procedures.

### 6. Publication Indexes

DA Pam 108-1 Index of Army Motion Pictures, Film Strips, Slides, and Photo Recordings.

DA Pam 310-1 Index of Administrative Publications.

DA Pam 310-2 Index of Blank Forms.

DA Pam 310-3 Index of Doctrinal, Training, and Organizational Publications.

DA Pam 310-4 Index of Technical Manuals, Technical Bulletins, Supply Manuals (types 4,  
6, 7, 8, and 9), Supply Bulletins, Lubrication Orders, and Modification Work  
Orders.

DA Pam 310-5 Index of Graphic Training Aids and Devices.

DA Pam 310-6 Index of Supply Catalogs and Supply Manuals.

### 7. Radio Interference Suppression

TM 11-483 Radio Interference Suppression.

### 8. Shipment and Limited Storage

AR 743-505 Limited Storage of Corps of Engineers Mechanical Equipment.  
TM 38-230 Preservation, Packaging, and Packing of Military Supplies and Equipment.

## 9. Supply Publications.

FSC C9100-IL

Fuels, Lubricants, Oils, and Waxes.

TM 5-4320-233-25P

Pump, Centrifugal, Gasoline Driven, Skid Mounted, 6 Inch, 1120 GPM, Self Priming (Carver Model K 906EWA), FSN 4320-968-6260 Organizational, Direct and General Support and Depot Maintenance Repair Parts and Special Tools List.

## 10. Training Aids

FM 5-25

Explosives and Demolition.

FM 21-5

Military Training.

FM 21-6

Techniques of Military Instruction.

FM 21-30

Military Symbols.

**APPENDIX II**  
**BASIC ISSUE ITEMS LIST AND MAINTENANCE AND OPERATING SUPPLIES**

---

**Section I. INTRODUCTION**

**1. General**

Section II lists the accessories, tools, and publications required for maintenance and operation by the operator, initially issued with, or authorized for the pump. Section III lists the maintenance and operating supplies required for initial operation.

**2. Explanation of Columns Contained in Section II**

a. *Source Codes* The information provided in each column is as follows:

- (1) *Materiel* This column is left blank. For identification of agencies assigned supply responsibility for parts, refer to appropriate Federal and Department of Army Supply Catalogs.
- (2) *Source* The selection status and source of supply for each part are indicated by one of the following code symbols:
  - (a) P-applied to high-mortality repair parts which are stocked in or supplied from the army supply system, and authorized for use at indicated maintenance categories.
  - (b) P<sup>3/4</sup> applied to repair parts which are low-mortality parts, stocked in or supplied from the army supply system and authorized for installation at indicated maintenance categories.
  - (c) X2-applied to repair parts which are not stocked. The indicated maintenance category requiring such repair parts will attempt to obtain them through cannibalization; if not obtainable through cannibalization, such repair parts will be requisitioned with supporting justification through normal supply channels.
- (3) *Maintenance*. The lowest maintenance level authorized to use, stock, install, or

manufacture the part is indicated by the following code symbol:

O-Organizational Maintenance

*Note.* When no code is shown in the recoverability column the part is considered expendable.

(a) *Federal Stock Number* If a Federal stock number is available for a part, it will be shown in this column, and will be used for requisitioning purposes.

(b) *Description*

1. The item name and a brief description of the part are shown.

2. A five-digit Federal supply code for manufacturers and/or other supply services is shown in parentheses followed by the manufacturer's part number. This number will be used for requisitioning purposes when no Federal stock number is indicated in the Federal stock number column. Example: (08645) 86453.

(c) *Unit of Issue* If no abbreviation is shown in this column, the unit of issue is "each".

(d) *Quantity Authorized* This column lists the quantities of repair parts, accessories, tools, or publications authorized for issue to the equipment or crew as required.

(e) *Quantity Issued with Equipment* This column lists the quantities of repair parts, accessories, tools, or publications that are initially issued with each item of equipment. Those indicated by an asterisk are to be requisitioned through normal supply channels as required.

(f) *Illustrations.* This column is subdivided into two columns which provide the following information:

1. *Figure number.* Provides the identifying number of the illustration.
2. *Item number.* Provides the referenced number for the parts shown in the illustration.

### 3. Federal Supply Code for Manufacturers

14351.....Continental Motor Corp., Muskegon, Mich.  
70040.....A. C. Spark Plug Div. of General Motors Corp., Flint, Mich.

### 4. Explanation of Columns Contained in Section III

a. *Item.* This column contains numerical sequenced item numbers, assigned to each component application, to facilitate reference.

b. *Component Application.* This column identifies the component application of each maintenance or operating supply item.

c. *Source of Supply.* This column is left blank.

For identification of agencies assigned supply responsibility for parts, refer to appropriate Federal and Department of Army Supply Catalogs.

d. *Federal Stock Number.* The Federal stock number will be shown in this column and will be used for requisitioning purposes.

e. *Description.* The item and a brief description are shown.

f. *Quantity Required for Initial Operation.* This column lists the quantity of each maintenance or operating supply item required for initial operation of the equipment.

g. *Quantity Required for 8 Hours Operation*  
Quantities listed represent the estimated requirements for an average 8 hours of operation.

h. *Notes.* This column contains informative notes keyed to data appearing in the preceding column.

## Section II. BASIC ISSUE ITEMS LIST

Source codes				Federal Stock Stock No.	Description	Unit of issue	Quantity authorized	Quantity issued with equipment	Illustrations	
Material	Source	Maintenance	Recoverability						Figure	Item
	P	O	-----	6140-057-2554	GROUP 31-BASIC ISSUE ITEMS, MANUFACTURER INSTALLED					
	P	O	-----	3030-821-8276	3100--BASIC ISSUE ITEMS, MANUFACTURER OR DEPOT INSTALLED					
	P	O	-----	3030-528-5079	BATTERY: storage, 12-volt 6-cell (repair parts manual group 0612)		2	2		
	P	O	-----	7510-889-3494	BELT, FAN: drive (96906) MS51070-49 (repair parts manual group 0505)		1	1		
	P	O	-----	7520-559-9618	BELT, GENERATOR: drive (96906) MS-51066-29. (repair parts manual group 0601)		1	1		
	P	O	-----	2940-141-9026	BINDER, LOOSE-LEAF: U.S. Army Equipment Log Book. Note: Initial issue and replenishment will be made in accordance with TM 38-750.		1	1	1	4
	P	O	-----		CASE: maintenance and operational manuals, cotton duck, water-repellent, mildew-resistant, MIL-B-17743.		5	5		
	X2	O	-----		CARTRIDGE AND GASKET: oil filter (73370) C-31PL and 11582. (repair parts manual group 0106)		1	1		
					CRANK, HAND engine starting (14351) PF186P3081. (repair parts manual group 0107)					

Source codes				Federal Stock Stock No.	Description	Unit of issue	Quan- tity au- thor- ized	Quan- tity issued with equip- ment	Illus- trations	
Ma- te- riel	Source	Main- te- nance	Re- cover- ability						Fig- ure	Item
					3100-BASIC ISSUE ITEMS, MANUFACTURER OR DEPOT INSTALLED-Continued					
					DEPARTMENT OF THE ARMY OP- ERATOR, ORGANIZATIONAL, DIRECT AND GENERAL SUPPORT AND DE- POT MAINTENANCE MANUAL TM 5-4320-233-15.	-----	2	2		
					DEPARTMENT OF THE ARMY LUBRI- CATION ORDER LO 5-4320-233-15.	-----	1	1		
	P	O	-----		GASKET BOWL (70040) 5590037 (repair parts manual group 0309)	-----	3	3		
	P	O	-----	2805-393-6418	GASKET SET: engine (14351) MS3300-102_Set (repair parts manual group 0100)		1	1		
	P	O	-----	2920-848-6078	REPAIR KIT, MAGNETO (09033) M1362 (repair parts manual group 0605)	-----	1	1		
	P	O	-----	2920-810-7082	SPARK PLUG (96906) MS51009-1 (repair parts manual group 0605)	-----		6	6	
	P	O	-----	6810-264-9063	SULPHURIC ACID: electrolyte (repair parts manual group 0612)	Gal	4	4		
					GROUP 32-BASIC ISSUE ITEMS, TROOP INSTALLED					
					3200--BASIC ISSUE ITEMS, TROOP INSTALLED OR AUTHORIZED					
	P	O	-----	5120-223-7396	PLIERS, SLIP JOINT: stght nose, w/cutter, 6 in. lg.		1	*		
	P1	O	-----	5975-473-6358	ROD, GROUND, W/CABLE AND CLIP		1	*		
	P	O	-----	5120-293-3169	SCREWDRIVER, FLAT TIP: -.6 in. W flared tip 6 in. lg blade.		1	*		
	P	O	-----	5120-240-5328	WRENCH, OPEN END, ADJUSTABLE: sgl-hd, 8 in. lg.		1	*		

TAGO 6358-A

### Section III. MAINTENANCE AND OPERATING SUPPLIES

Item	Component Application	Source of supply	Federal Stock No.	Description	Quantity required for initial operation	Quantity required for 8 hours operation	Notes
1	0101 CRANK-CASE (1).	-----	-----	OIL, LUBRICATING: 5 gal pail as follows:	-----	-----	(1) Includes quantity of oil to fill engine oil system as follows: 7-qt Crankcase 1-qt Oil Filter (2) See FSC C9100-IL for additional data and requisitioning procedures. (3) See current LO for grade application and replenishment intervals.  prescribed in item 1 above. (5) Tank capacity.
			9150-265-9435 (2)	OE-30 -----	8 qt	(3)	
			9150-265-9428(2)	OE-10-----	8 qt	(3)	
2	0304-AIR CLEANER.	-----	9150-242-7603(2)	OES-----	8 qt	(3)	
3	0306-FUEL TANK.	-----	-----	OIL, LUBRICATING (4).	1 qt	(3)	
			-----	FUEL, GASOLINE:			
			9130-160-1818	Bulk as follows:	13 gal (5)		
			9130-160-1830	Automotive combat 91A.	13 gal (5)		
4	0501 RADIATOR.	-----	-----	Automotive combat 91C.			
			-----	WATER ANTI-FREEZE: 55-gal drum as follows:	33 qt	(4) Use oil as	
			6850-243-1990	ANTIFREEZE:	20 qt		
			6850-174-1805	Ethylene glycol.	33 qt		
5	5501-PUMP BEARING HOUSING.	-----	-----	ANTIFREEZE:	¼ qt	(3)	
6	GREASE POINTS.	-----	-----	Compound artic.			
			9150-190-0904	OIL, LUBRICATING (4).	1 lb	(3)	
			-----	GREASE, AUTOMOTIVE AND ARTILLERY:			
			-----	1-lb can as follows:			
			-----	GAA -----			

## APPENDIX III MAINTENANCE ALLOCATION CHART

---

### Section I. INTRODUCTION

#### 1. General

a. Section I provides a general explanation of all maintenance and repair functions authorized at various maintenance levels.

b. Section II designates overall responsibility for the performance of maintenance operations on the identified end item or component. The implementation of the maintenance tasks upon the end item or component will be consistent with the assigned maintenance operations.

c. Section III lists the special tools and test equipment required for each maintenance operation as referenced from section II.

d. Section IV contains supplemental instructions, explanatory notes and/or illustrations required for a particular maintenance function.

#### 2. Explanation of Columns in Section II

a. Functional Group Number. The functional group is a numerical group set up on a functional basis. The applicable functional grouping indexes (obtained from TB 750-93-1 Functional Grouping Codes) are listed on the MAC in the appropriate numerical sequence. These indexes normally are set up in accordance with their function and proximity to each other.

b. Component Assembly Nomenclature. This column contains a brief description of the components of each functional group.

c. Maintenance Operations and Maintenance Levels. This column lists the various maintenance operations (A through J) and indicates the lowest maintenance level authorized to perform these operations.

The symbol designation for the various maintenance levels are as follows:

O/C-Operator or crew  
O -Organizational maintenance  
F -Direct support maintenance  
H -General support maintenance  
D-Depot maintenance

The Maintenance Operations are defined as follows:

A---SERVICE: Operations required periodically to keep the item in proper operating condition, i.e., to clean, preserve, drain, paint, and replenish fuel, lubricants, hydraulic, and deicing fluids, or compressed air supplies.

B---ADJUST: Regulate periodically to prevent malfunction. Adjustments will be made commensurate with adjustment procedures and associated equipment specifications.

C---ALINE: Adjust two or more components of an electrical or mechanical system so that their functions are properly synchronized or adjusted.

D---CALIBRATE: Determine, check, or rectify the graduation of an instrument, weapon, or weapons system or components of a weapons system.

E---INSPECT: Verify serviceability and detect incipient electrical or mechanical failure by close visual examination.

F---TEST: Verify serviceability and detect incipient electrical or mechanical failure by measuring the mechanical or electrical characteristics of the item and comparing those characteristics with authorized standards. Tests will be made commensurate with test procedures and with calibrated tools and/or test equipment referenced in the MAC.

G---REPLACE: Substitute serviceable components, assemblies and subassemblies for unserviceable counterparts or remove and install the same item when required for the performance of other maintenance operations.

H---REPAIR: Restore to a serviceable condition by replacing unserviceable parts or by any other action required using available tools, equipment and skills-to include welding, grinding, riveting, straightening, adjusting, and facing.



I---OVERHAUL: Restore an item to a completely serviceable condition (as prescribed by serviceability standards developed and published by the commodity commands) by employing techniques of "Inspect and Repair Only as Necessary" (IROAN). Maximum use of diagnostic and test equipment is combined with minimum disassembly during overhaul. "Overhaul" may be assigned to any level of maintenance except organizational, provided the time, tools, equipment, repair parts authorization, and technical skills are available at that level. Normally, overhaul as applied to end items, is limited to depot maintenance level.

J---REBUILD: Restore to a condition comparable to new by disassembling to determine the condition of each component part and reassembling using serviceable, rebuilt, or new assemblies, subassemblies, and parts.

e. *Reference Note.* This column, subdivided into columns K and L, is provided for referencing the SPECIAL TOOL AND TEST EQUIPMENT REQUIREMENTS (sec III) and REMARKS (sec IV) that may be associated with maintenance operations (sec II).

### 3. Explanation of Columns in Section III

a. *Reference Code.* This column consists of a number and a letter separated by a dash. The number references the T and TE requirements column on the MAC.

The letter represents the specific maintenance operation the item is to be used with. The letter is representative of columns A through J on the MAC.

b. *Maintenance Level.* This column shows the lowest level of maintenance authorized to use the special tool or test equipment.

c. *Nomenclature.* This column lists the name or identification of the tool or test equipment.

d. *Tool Number.* This column lists the manufacturer's code and part number, or Federal stock number, of tools and test equipment.

### 4. Explanation of Columns in Section IV

a. *Reference Code.* This column consists of two letters separated by a dash, both of which are references to section II. The first letter references column L and the second letter references a maintenance operation, column A through J.

b. *Remarks.* This column lists information pertinent to the maintenance operation being performed as indicated on the MAC section II.

## Section II. MAINTENANCE ALLOCATION CHART

Functional Group No.	Component assembly nomenclature	Essentiality	Maintenance operations								Maintenance levels				Note reference	
			A Service	B Adjust	C Align	D Calibrate	E Inspect	F Test	G Replace	H Repair	I Overhaul	J Rebuild	K T&TE rgmt	L Remarks		
01	ENGINE															
0100	Engine assembly-----		O/C					O/C	O	F	F	H	D	-----	A	
0105	Valves:															
	Seats and valves -----									F	F				B	
	Tappet, valve -----			O						F						
0106	Engine Lubrication System:															
	Filter and breather, oil-----		O/C							O						
	Regulator, pressure -----			O						O						
03	FUEL SYSTEM															
0301	Carburetor -----			O/C						O						
0302	Fuel pump -----			O/C						O						
0304	Air cleaner -----		O/C							O						
0306	Tanks, Lines, Fittings:															
	Tank, fuel-----		O/C							F						
0309	Fuel filters -----		O/C							O						
05	COOLING SYSTEM															
0501	Radiator -----		O/C							F	F					
0504	Water pump -----		O/C							O					C	
0505	Fan Assembly:															
	Belt, V-drive-----			O/C						O						

Functional Group No.	Component assembly nomenclature	Essentiality	Maintenance operations										Maintenance levels		Note reference		
			A	B	C	D	E	F	G	H	I	J	K	L			
			Service	Adjust	Align	Calibrate	Inspect	Test	Replace	Repair	Overhaul	Rebuild	T&TE rgmt	Remarks			
06	ELECTRICAL SYSTEM																
0601	Generator-----									O	O	F					D
602	Generator regulator-----		O							O	O	F					
0603	Starting motor-----									O	O	F					E
	Solenoid-----									O	O						
0605	Ignition Components:																
	Magneto assembly-----		O	O						O	F						F
	Spark plugs-----		O	O						O							
0612	Batteries, storage-----		O/C							O	O/C						
47	GAGES																
4701	Instruments:																
	Adapter, tachometer-----		O/C								O						
55	PUMPS																
5501	Pump assembly-----		O/C					O/C			F	F	H				
5507	Pump drive-----											F	F				

### Section III. SPECIAL TOOL AND SPECIAL TEST EQUIPMENT REQUIREMENTS

Reference code	Maintenance level	Nomenclature	Tool No.
		No special tools or test equipment required.	

### Section IV. REMARKS

Reference code	Remarks
A-F	Test includes engine operation and compression.
B-H	Repair of valves and seats includes refacing.
C-H	Repair of water pump includes installing repair kit
D-H	Repair of generator includes installing repair kit.
E-H	Repair of starter includes installing repair kit.
F-H	Repair of magneto includes installing repair kit.

## INDEX

	Paragraph	Page		Paragraph	Page
Accessory items.....	5c	5	Batteries:		
Adjustment:			Description and function.....	64a	34
Carburetor.....	59a	28	Replacement.....	65c	34
Generator and fan belt.....	67a	35	Service.....	65a	34
Generator regulator.....	68a	36	Testing.....	65b	34
Governor.....	61a	30	Battery disconnect switch:		
Magneto points.....	70d	39	Cleaning and inspection.....	94b	50
Oil pressure relief valve.....	81a	44	Description and function.....	24	12
Valve tappets.....	83	46	Installation.....	94c	50
Adjustment data.....	5e	7	Removal.....	94a	50
Air cleaner:			Belt, generator and fan:		
Cleaning and inspection.....	60c	31	Adjustment.....	67a	35
Description and function.....	57d	27	Replacement.....	67b	35
High altitudes.....	32c	16	Camshaft, crankshaft, and crankshaft		
Installation.....	60d	30	bearings:		
Lubrication.....	34e	17	Cleaning and inspection.....	121b	83
Removal.....	605	30	Camshaft bearing replacement.....	121d	84
Service.....	60a	30	Installation.....	121c	83
Air preheater:			Removal.....	121a	82
Cleaning and inspection.....	85b	47	Capacities.....	5d	7
Installation.....	85c	47	Carburetor:		
Removal.....	85a	46	Adjustment.....	59a	28
Ammeter:			Cleaning and inspection.....	59c	29
Cleaning and inspection.....	91b	49	Description and function.....	57c	27
Description and function.....	15	11	High altitudes.....	32b	16
Installation.....	91c	49	Installation.....	59d	29
Removal.....	91a	49	Removal.....	59b	29
Antifreeze requirements.....		98	Care of lubricants.....	34a	17
Assembled engine, stub shaft, and dash:			Check valve and suction head:		
Cleaning and inspection.....	102b	58	Assembly and installation.....	125c	85
Installation.....	102c	58	Cleaning and inspection.....	125b	85
Removal.....	102a	57	Removal and disassembly.....	125a	85
Assembly:			Choke control:		
Coupling.....	100d	56	Cleaning and inspection.....	95b	50
Engine block.....	122e	85	Description and function.....	23	12
Generator.....	10Sd	63	Installation.....	95c	50
Governor.....	106d	61	Removal.....	95a	50
Impeller, shaft, seal and bearings.....	127c	87	Cleaning and inspection:		
Magneto.....	110d	67	Air cleaner.....	60c	30
Oil pump.....	118d	77	Air preheater.....	85b	47
Pistons and connecting rod.....	119e	78	Ammeter.....	91b	49
Skid base and related parts.....	129c	88	Assembled engine, stub shaft, and		
Starting motor.....	109d	66	dash.....	102b	58
Stub shaft.....	10ad	59	Battery disconnect switch.....	94b	50
Suction head and check valve.....	125c	85	Carburetor.....	59c	29
Water pump.....	113d	71	Choke control.....	95b	29
Base plan.....	5i	7	Coupling.....	100c	56
Basic issue tools and equipment.....	33.1	71	Crankshaft, crankshaft bearings,		
			and camshaft.....	121b	83
			Cylinder head.....	115b	72
			Dash.....	104b	59

	Paragraph	Page
Cleaning and inspection-Continued		
Discharge elbow and lifting bail.....	126b	85
Discharge pressure gage.....	87b	48
Engine block.....	122b, c	84, 85
Engine oil pressure gage and safety switch.....	90b	49
Engine water temperature gage and safety switch.....	92b	49
Flywheel and flywheel housing.....	120b	81
Fuel lines and fittings.....	63c	32
Fuel primer pump.....	62b	32
Fuel pump.....	58c	28
Generator.....	66c	35
Governor.....	61c, 106c	31, 61
Hood and side panels.....	99b	51
Impeller, shaft, seal, and bearings.....	127b	87
Intake pressure gage.....	88b	49
Magneto.....	70b, 110c	39, 67
Magneto switch.....	96b	50
Manifolds.....	86b	47
Muffler and exhaust pipe.....	84b	46
Oil filter.....	78c	44
Oil pan and filler blocks.....	117b	76
Oil pump.....	11&c	77
Pistons and connecting rods.....	119b	78
Pump.....	101b	57
Radiator.....	112b	70
Skid base and related parts.....	129b	88
Starter button.....	97b	50
Starting motor.....	69b	38
Stub shaft.....	103c	59
Suction head and check valve.....	125b	85
Tachometer and hourmeter.....	89b	49
Throttle control.....	93b	49
Water pump.....	74b, 113c	41, 70
Cleaning, inspection, and repair:		
Generator.....	108c	61
Starting motor.....	109c	63
Valve and valve tappets.....	116b	74
Connecting rods and pistons:		
Cleaning and inspection.....	119b	78
Removal and disassembly.....	119a	78
Repair and assembly.....	119c	78
Controls and instruments:		
Ammeter.....	15, 91	11, 40
Battery disconnect switch.....	24, 94	12, 50
Choke control.....	23, 95	12, 50
Discharge pressure gage.....	19, 87	12, 48
Engine oil pressure gage and safety switch.....	16, 90	11, 49
Engine water temperature gage and safety switch.....	14, 92	11, 49
Fuel primer pump handle.....	18	12
General.....	12	11
Intake pressure gage.....	22, 88	12, 49
Liquid level gage.....	24.1	12
Magneto switch.....	20, 96	12, 50
Starter button.....	21, 97	12, 50
Tachometer and hourmeter.....	13, 89	11, 49
Throttle.....	17, 93	11, 49
Coolant line and hose replacement.....	73	40

	Paragraph	Page
Coolant system:		
Coolant line and hose replacement.....	73	40
Description and function.....	72, 111	40, 69
Extreme cold.....	28d	15
Extreme heat.....	29d	16
Radiator repair.....	112	69
Radiator service.....	76	41
Thermostat.....	75	41
Water pump.....	74	40
Water pump repair.....	113	71
Coupling:		
Assembly.....	100d	58
Cleaning and inspection.....	100c	56
Disassembly.....	100b	56
Installation.....	100e	56
Removal.....	100a	55
Crankcase breather service.....	79	44
Crankshaft, crankshaft bearings, and camshaft:		
Cleaning and inspection.....	121b	83
Crankshaft bearing replacement.....	121d	84
Installation.....	121c	83
Removal.....	121a	82
Cylinder head:		
Cleaning and inspection.....	115b	72
Installation.....	115c	74
Removal.....	115a	72
Daily preventive maintenance services.....	36	20
Dash:		
Cleaning and inspection.....	104b	59
Installation.....	104c	59
Removal.....	104a	59
Definitions:		
Interference.....	52a	26
Interference suppression.....	52b	26
Description and data:		
Description.....	3	4
Differences in models.....	5.1	7
Identification.....	4	4
Tabulated data.....	5	5
Description and function:		
Air cleaner.....	57d	27
Ammeter.....	15	11
Batteries.....	64a	34
Battery disconnect switch.....	24	12
Carburetor.....	57c	27
Choke control.....	23	12
Coolant system.....	72, 111	40, 69
Discharge pressure gage.....	19	12
Engine.....	82	46
Engine assembly.....	114a	72
Engine electrical system.....	64, 107	34, 61
Engine oil pressure gage and safety switch.....	16	11
Engine speed governor.....	105	60
Engine water temperature gage and safety switch.....	14	11
Fuel lines and fittings.....	57h	28
Fuel primer pump.....	57f	28
Fuel pump.....	57b	27
Fuel system.....	57a	27
Fuel tank.....	57g	28

ParagraphPage			Paragraph Page		
Description and function-Continued			Engine block:		
Generator.....	64b	34	Assembly and installation.....	122e	85
Generator regulator.....	64c	34	Cleaning.....	122b	84
Governor.....	57e	28	Inspection.....	122c	85
Hood and side panels.....	98	50	Reboring.....	122d	85
Intake pressure gage.....	22	12	Removal and disassembly.....	122a	84
Lubrication system.....	77a	43	Engine electrical system:		
Magneto.....	64e	34	Batteries.....	65	34
Magneto switch.....	20	12	Description and function.....	64,107	34, 61
Oil filter.....	77d	43	Generator.....	66	34
Oil pressure relief valve.....	77c	43	Generator and fan belt.....	67	35
Oil pump.....	77b	43	Generator regulator.....	68	36
Skid base and related parts.....	128a	88	Generator repair.....	108	61
Starter button.....	21	12	Magneto.....	70	39
Starting motor.....	64d	34	Magneto repair.....	110	67
Stub shaft.....	103b	58	Spark plugs and ignition leads.....	71	40
Tachometer and hourmeter.....	13	11	Starting motor.....	69	38
Throttle control.....	17	11	Starting motor repair.....	109	63
Differences in models.....	5.1	7	Engine oil pressure gage and safety switch:		
Disassembly:			Cleaning and inspection.....	90b	49
Coupling.....	100b	56	Description and function.....	16	11
Engine block.....	122a	84	Installation.....	90c	49
Generator.....	108b	61	Removal.....	90a	49
Governor.....	106b	61	Engine overhaul:		
Impeller, shaft, seal, and bearings.....	127a	87	Crankshaft and camshaft.....	121	82
Magneto.....	110b	67	Cylinder head.....	115	72
Oil pump.....	118b	77	Engine assembly.....	114	72
Pistons and connecting rods.....	119a	78	Engine block.....	122	84
Skid base and related parts.....	129a	88	Flywheel and flywheel housing.....	120	80
Starting motor.....	109b	63	Oil pan and filler blocks.....	117	76
Stub shaft.....	103b	58	Oil pump.....	118	77
Suction head and check valve.....	125a	85	Piston and connecting rods.....	119	78
Water pump.....	113b	71	Valves and valve tappets.....	116	74
Discharge elbow and lifting bail:			Engine speed governor:		
Cleaning and inspection.....	126b	85	Description and function.....	105	60
Installation.....	126c	85	Governor repair.....	106	61
Removal.....	126a	85	Engine troubleshooting:		
Discharge line.....	10b	10	Engine fails to start or hard to start.....	39	25
Discharge pressure gage:			Engine lacks power.....	46	25
Cleaning and inspection.....	87b	48	Engine misses or runs erratically.....	40	25
Description and function.....	19	12	Engine noisy.....	41	25
Installation.....	87c	49	Engine overheats.....	44	25
Removal.....	87a	48	Engine stops suddenly.....	42	25
Draining fuel tank.....	63a	32	Exhaust smoke excessive.....	45	25
Dusty or sandy areas:			Generator fails to function.....	47	26
Fuel system.....	30c	16	Oil pressure low.....	43	25
General.....	30a	16	Starting motor does not operate properly.....	48	26
Lubrication.....	30b	16	Engine water temperature gage and safety switch:		
Efficiency of varying elevations.....	32	16	Cleaning and inspection.....	92b	49
Electrical system in extreme cold.....	28e	15	Description and function.....	14	11
Engine:			Installation.....	92c	49
Air preheater.....	5	46	Removal.....	92a	49
Description and function.....	82, 114a	46, 72	Exhaust pipe and muffler:		
Installation.....	114c	72	Cleaning and inspection.....	84b	46
Manifolds.....	86	47	Installation.....	84c	46
Muffler and exhaust pipe.....	84	46	Removal.....	84a	46
Nameplate.....	4a	4	Exhaust piping.....	10c	10
Removal.....	114b	72	Exhaust smoke excessive.....	45	25
Tabulated data.....	5b	5			
Valve tappet adjustment.....	83	46			

	Paragraph	Page		Paragraph	Page
Extreme cold:			Generator fails to function.....	47	26
Cooling system.....	28d	15	Generator regulator:		
Electrical system.....	28e	15	Adjustment.....	68a	36
Fuel system.....	28b	15	Description and function.....	64c	34
General .....	28a	15	Replacement.....	68b	38
Lubrication .....	28c	15	Testing.....	68a	36
Extreme heat:			Governor:		
Cooling system.....	29d	16	Adjustment.....	61a	30
Fuel system.....	29b	16	Assembly.....	106d	61
General .....	29a	16	Cleaning and inspection.....	61c, 106c	31, 61
Lubrication.....	29c	16	Description and function.....	57e	28
Fabrication of fuel lines and fittings.....	63d	32	Disassembly .....	106b	61
Filler blocks and oil pan:			Installation .....	61d	31
Cleaning and inspection.....	117b	76	Removal.....	61b	31
Installation.....	117c	76	Ground strap.....	56b	27
Removal.....	117a	76	High altitudes:		
Flywheel and flywheel housing:			Air cleaner .....	32c	16
Cleaning and inspection.....	120b	81	Carburetor.....	32b	16
Installation.....	120c	81	General .....	32a	16
Removal .....	120a	80	Ventilation.....	32d	16
Fuel primer pump:			High humidity.....	31b	16
Cleaning and inspection.....	62b	32	Hood and side panels:		
Description and function.....	57f	28	Cleaning and inspection.....	99b	51
Installation.....	62c	32	Description and function.....	98	50
Removal .....	62a	32	Installation .....	99c	52
Fuel primer pump handle.....	18	12	Removal.....	99a	50
Fuel pump:			Hourmeter and tachometer:		
Cleaning and inspection.....	58c	28	Description and function.....	13	11
Description and function.....	57b	27	Installation .....	89b	49
Installation.....	58d	28	Removal .....	89a	49
Removal .....	58b	28	Identification:		
Service .....	58a	28	Engine nameplate.....	4a	4
Fuel system:			Pump nameplate.....	4b	4
Air cleaner.....	60	30	Impeller, shaft, seal, and bearings:		
Carburetor.....	59	28	Assembly and installation.....	127c	87
Description and function.....	57	27	Cleaning and inspection.....	127b	87
Dusty or sandy areas.....	30c	16	Removal and disassembly.....	127a	87
Extreme cold.....	28b	15	Inspection of equipment.....	8	8
Extreme heat.....	29b	16	Installation:		
Fuel primer pump.....	62	32	Air cleaner .....	60d	30
Fuel pump .....	58	28	Air preheater.....	85c	47
Fuel tank, lines, and fittings.....	63	32	Ammeter .....	91c	49
Governor .....	61	30	Assembled engine, stub shaft, and dash.....	102c	58
Fuel tank, lines, and fittings:			Battery disconnect switch.....	94c	50
Cleaning and inspection.....	63c	32	Carburetor.....	59d	29
Description and function.....	57g, 57h	28	Choke control.....	95c	49
Draining fuel tank.....	63a	32	Coupling .....	100c	56
Fabrication .....	63d	32	Crankshaft and camshaft.....	121c	83
Installation.....	63e	32	Cylinder head.....	115c	74
Removal.....	63b	32	Dash .....	104c	59
Generator:			Discharge elbow and lifting bail.....	126c	85
Assembly .....	108d	63	Discharge pressure gage.....	87c	49
Cleaning and inspection.....	66c	35	Engine assembly.....	114c	72
Cleaning, inspection, and repair.....	108c	61	Engine block.....	122e	85
Description and function.....	64b	34	Engine oil pressure gage and safety switch .....	90c	49
Disassembly.....	108b	61	Engine water temperature gage and safety switch.....	92c	49
Installation.....	66d	35	Flywheel and flywheel housing.....	120c	81
Removal .....	66b	34	Fuel lines and fittings.....	63e	32
Testing .....	66a	34	Fuel primer pump.....	62c	32
Generator and fan belt:					
Adjustment.....	67a	35			
Replacement.....	67b	35			

	Paragraph	Page		Paragraph	Page
Installation-Continued			Magneto:		
Fuel pump .....	58d	28	Assembly .....	110d	67
Generator.....	66d	35	Cleaning and inspection.....	70b, 110c	39, 67
Governor.....	61d	31	Description and function.....	64e	34
Hood and side panels.....	99c	52	Disassembly .....	110b	67
Impeller, shaft, seal, and bearings.....	127c	87	Magneto point replacement.....	70d	39
Intake pressure gage.....	88b	49	Removal .....	70a	39
Magneto .....	70c	39	Timing and installation.....	70c	39
Magneto switch.....	96c	50	Magneto switch:		
Manifolds.....	86c	47	Cleaning and inspection.....	96b	50
Muffler and exhaust pipe.....	84c	46	Description and function.....	20	12
Oil filter .....	78d	44	Installation.....	96c	50
Oil pan and filler blocks.....	117c	76	Removal .....	96a	50
Oil pump .....	118e	78	Maintenance and operating supplies.....	5j	7
Pump .....	101c	57	Manifolds:		
Radiator.....	112d	71	Cleaning and inspection.....	86b	47
Skid base and related parts.....	128c	88	Installation .....	86c	47
Starter button .....	97c	50	Removal .....	86a	47
starting motor.....	69c	38	Methods of attaining radio interference		
Stub shaft and drive.....	103e	59	suppression.....	55	27
Suction head and check valve.....	125c	85	Model differences.....	5.1	7
Tachometer and hourmeter.....	89c	49	Movement to a new worksite:		
Thermostat.....	75c	41	Long distance move.....	11b	11
Throttle control.....	93c	50	Short distance move.....	11a	11
Valves and valve tappets.....	116c	76	Muffler and exhaust pipe:		
Water pump.....	74c	41	Cleaning and inspection.....	84b	46
Installation instructions:			Installation .....	84c	46
Discharge line.....	10b	10	Removal.....	84a,	46
Exhaust piping.....	10c	10	Nameplates:		
Suction line.....	10a	9	Engine.....	4a	4
Intake pressure gage:			Pump .....	4b	4
Cleaning and inspection.....	88b	49	Noisy pump operation.....	50	26
Description and function.....	22	12	Oil filter:		
Installation.....	88c	49	Cleaning and inspection.....	78c	44
Removal .....	88a	49	Description and function.....	77d	43
Interference:			Installation.....	78d	44
Definition .....	52a	26	Lubrication.....	34d	17
General source.....	54	26	Removal.....	78b	43
Suppression.....	52b	26	Service.....	78a	43
Lifting bail and discharge elbow:			Oil line and fitting replacement.....	80	44
Cleaning and inspection.....	126b	85	Oil pan and filler blocks:		
Installation.....	126c	85	Cleaning and inspection.....	117b	76
Removal .....	126a	85	Installation.....	117c	76
Liquid level gage.....	24.1	12	Removal .....	117a	76
Long distance move to a new worksite..	11b	11	Oil pressure low.....	43	25
Lubrication:			Oil pressure relief valve:		
Air cleaner .....	34e	17	Adjustment.....	81a	44
Care of lubricants.....	34a	17	Description and function.....	77c	43
Cleaning.....	34b	17	Replacement.....	81b	44
Dusty or sandy areas.....	30b	16	Oil pump:		
Extreme cold .....	28c	15	Assembly .....	118d	77
Extreme heat.....	29c	16	Cleaning and inspection.....	118c	77
Oil filter .....	34d	17	Disassembly .....	118b	77
Operation after lubrication.....	34c	17	Installation .....	118e	78
Lubrication system:			Removal.....	118a	77
Crankcase breather service.....	79	44	Operating details:		
Description and function.....	77	43	Details on performance of pump.....	27d	13
Oil filter service .....	78	43	Positioning of controls.....	27c	13
Oil line and fitting replacement.....	80	44	Preliminary steps.....	27a	13
Oil pressure relief valve.....	81	44	Starting the equipment.....	27b	13

	Paragraph	Page
Operation immediately after lubrication..	34c	17
Operation under unusual conditions:		
Dusty or sandy areas.....	30	16
Extreme cold .....	28	15
Extreme heat.....	29	16
High altitudes.....	32	16
Salt water or high humidity.....	31	16
Operation under usual conditions:		
Operating details.....	27	13
Starting .....	25	13
Stopping.....	26	13
Operator and crew preventive maintenance:		
Daily services.....	36	20
General .....	35	20
Quarterly services.....	37	20
Organizational maintenance repair parts	33.2	17
Overhaul, engine:		
Cylinder head.....	115	72
Engine assembly.....	114	72
Manifolds.....	116	74
Performance data.....	5k	7
Performance of pump.....	27d	13
Pistons and connecting rods:		
Cleaning and inspection.....	119b	78
Removal and disassembly.....	119a	78
Repair and assembly.....	119c	78
Position of controls.....	27c	13
Preliminary operating details.....	27a	13
Preventive maintenance:		
Daily services.....	36	20
General .....	35	20
Quarterly services.....	37	20
Priming pump .....	27a	13
Pump:		
Cleaning and inspection.....	101b	57
Efficiency of varying elevations.....	32	16
Installation.....	101c	57
Nameplate .....	4b	4
Performance details.....	27d	13
Removal .....	101a	56
Tabulated data .....	5a	5
Pump repair:		
Discharge elbow and lifting bail.....	126	85
General.....	123	85
Impeller, shaft, seal, and bearings.....	127	87
Pump .....	124	85
Suction head and check valve.....	125	85
Pump troubleshooting:		
Noisy pump operation.....	50	26
Pump fails to deliver rated capacity....	51	26
Pump fails to prime .....	49	26
Purpose of radio interference suppression .....	53	26
Quarterly preventive maintenance services.....	37	20
Radiator:		
Cleaning.....	112b	70
Installation.....	112d	71
Removal .....	112a	69

	Paragraph	Page
Radiator-Continued		
Service.....	76	41
Testing and repair.....	112c	70
Radio interference suppression:		
Definitions.....	52	26
General methods to attain proper suppression .....	55	27
General source of interference.....	54	26
Purpose .....	53	26
Replacement of suppression components.....	56	27
Reboring cylinders.....	122d	85
Record and report forms.....	2	3
Removal:		
Air cleaner.....	60b	30
Air preheater.....	85a	46
Ammeter.....	91a	49
Assembled engine, stub shaft, and dash .....	102a	57
Battery disconnect switch.....	94a	50
Carburetor .....	59b	29
Choke control.....	95a	50
Coupling.....	100a	55
Crankshaft and camshaft.....	121a	82
Cylinder head.....	115a	72
Dash .....	104a	59
Discharge elbow and lifting bail.....	126a	85
Discharge pressure gage.....	87a	48
Engine .....	114b	72
Engine block .....	122a	84
Engine oil pressure gage and safety switch .....	90a	49
Engine water temperature gage and safety switch.....	92a	49
Flywheel and flywheel housing.....	120a	80
Fuel lines and fittings.....	63b	32
Fuel primer pump.....	62a	32
Fuel pump.....	58b	28
Generator.....	66b	34
Governor.....	61b	31
Hood and side panels.....	99a	50
Impeller, shaft, seal and bearings.....	127a	87
Intake pressure gage.....	88a	49
Magneto .....	70a	39
Magneto switch.....	96a	50
Manifolds.....	86a	47
Muffler and exhaust pipe.....	84a	46
Oil filter .....	78b	43
Oil pan and filler blocks.....	117a	76
Oil pump.....	118a	77
Pistons and connecting rods.....	119a	78
Pump.....	101a	56
Radiator .....	112a	69
Skid base and related parts.....	128b	88
Starter button.....	97a	50
Starting motor.....	69a	38
Stub shaft and drive.....	103a	58
Suction head and check valve.....	125a	85
Tachometer and hourmeter.....	89a	49
Thermostat.....	75a	41
Throttle control.....	93a	49
Valves and valve tappets.....	116a	74
Water pump.....	74a	40



	Paragraph	Page		Paragraph	Page
Repair:			Skid base and related parts-Continued		
Generator.....	108	61	Installation.....	128c	88
Governor.....	106	61	Removal .....	128b	88
Magneto.....	110	67	Source of radio interference.....	54	26
Pistons and connecting rods.....	119c	78	Spark plugs and ignition leads:		
Radiator.....	112	69	Shielded ignition lead replacement.....	71b	40
Skid base and related parts.....	129	88	Spark plug service and replacement...	71a	40
Starting motor .....	109	63	Special tools and lubricants:		
Valves and valve tappets.....	116b	74	Basic issue tools and equipment..33.1	17	
Water pump.....	113	71	Lubrication information.....	34	17
Replacement:			Organizational maintenance repair		
Batteries.....	65c	34	parts .....	33.2	17
Coolant lines and hoses.....	73	40	Special tools and equipment.....	33	17
Crankshaft bearings.....	121d	84	Starter button:		
Generator and fan belt.....	67	35	Cleaning and inspection.....	97b	50
Generator regulator.....	68b	38	Description and function.....	21	12
Oil lines and fittings.....	80	44	Installation .....	97c	50
Oil pressure relief valve.....	81b	44	Removal .....	97a	50
Shielded ignition leads.....	71b	40	Starting .....	25, 27b	13
Spark plugs.....	71a	40	Starting motor:		
Starter solenoid.....	69e	39	Assembly .....	109d	66
Suppression components.....	56	27	Cleaning and inspection.....	69b	38
Replacement of suppression components:			Cleaning, inspection, and repair.....	109c	63
Ground strap.....	56b	27	Description and function.....	64d	34
Shielded ignition leads.....	56a	27	Disassembly.....	109b	63
Reverse flow flushing.....	76	41	Installation .....	69c	38
			Removal.....	69a	38
Salt water .....	31a	16	Starter solenoid replacement.....	69e	39
Sandy or dusty areas:			Testing .....	69d	38
Fuel system.....	30c	16	Starting motor does not operate properly	26	
General.....	30a	16	Stopping .....	26	13
Lubrication .....	30b	16	Stub shaft and drive:		
Scope .....	1	2	Installation .....	103e	59
Service:			Removal.....	103a	58
Air cleaner.....	60a	30	Stub shaft assembly.....	103d	59
Batteries.....	65a	34	Stub shaft cleaning and inspection.....	103c	59
Crankcase breather.....	79	44	Stub shaft disassembly.....	103b	58
Fuel pump .....	58a	28	Suction head and check valve:		
Oil filter.....	78a	43	Assembly and installation.....	125c	85
Radiator.....	76	43	Cleaning and inspection.....	125b	85
Spark plugs.....	71a	40	Removal and disassembly.....	125a	85
Service upon receipt of equipment:			Suction line .....	10a	9
Inspection of equipment.....	8	8	Suppression of radio interference:		
Installation instructions.....	10	9	Definition.....	52b	26
Movement to a new worksite.....	11	11	General methods.....	55	27
Servicing equipment.....	9	8	Tabulated data:		
Unloading equipment.....	6	8	Accessory items.....	5c	5
Unpacking equipment.....	7	8	Adjustment data.....	5e	7
Shielded ignition leads.....	56a, 71b	27, 40	Base plan.....	5i	7
Shipping dimensions.....	5h	7	Capacities .....	5d	7
Short distance move to a new worksite..	11a	11	Engine.....	5b	5
Side panels and hood:			Maintenance and operating supplies...	5j	7
Cleaning and inspection.....	99b	51	Performance data.....	5k	7
Description and function.....	98	50	Pump.....	5a	5
Installation.....	99c	52	Shipping dimensions.....	5h	7
Removal .....	99a	50	Torque data.....	5f	7
Skid base and related parts:			Wiring diagram.....	5g	7
Assembly .....	129c	88	Tachometer and hourmeter:		
Cleaning and inspection.....	129b	88	Cleaning and inspection.....	89b	49
Description and function.....	128a	88	Description and function.....	13	11
Disassembly.....	129a	88	Installation.....	89c	49
			Removal.....	89a	49

	Paragraph	Page		Paragraph	Page
Testing:			Troubleshooting-Continued		
Batteries.....	65b	34	Exhaust smoke excessive.....	45	25
Generator.....	66a	34	General.....	38	25
Generator regulator.....	68a	36	Generator fails to function.....	47	26
Starting motor.....	69d	38	Noisy pump operation.....	50	26
Radiator.....	112c	70	Oil pressure low.....	43	25
Thermostat.....	75b	41	Pump fails to deliver rated capacity....	51	26
Thermostat:			Pump fails to prime.....	49	26
Installation.....	75c	41	Starting motor does not operate		
Removal.....	75a	41	properly.....	48	26
Testing.....	75b	41	Unloading equipment.....	6	8
Throttle control:			Unpacking equipment.....	7	8
Cleaning and inspection.....	93b	50	Valves and valve tappets:		
Description and function.....	17	11	Cleaning, inspection, and repair.....	116b	74
Installation.....	93c	50	Installation.....	116c	76
Removal.....	93a	49	Removal.....	116a	74
Timing, magneto.....	70c	39	Valve tappet adjustment.....	83	46
Tools and equipment, special.....	33	17	Ventilation in high altitudes.....	32d	16
Torque data.....	5f	7	Water pump:		
Troubleshooting:			Assembly.....	113d	71
Engine fails to start or hard to start....	39	25	Cleaning and inspection.....	74b, 113c	41, 71
Engine lacks power.....	46	25	Disassembly.....	113b	71
Engine misses or runs erratically.....	40	25	Installation.....	74c	41
Engine noisy.....	41	25	Removal.....	74a	40
Engine overheats.....	44	25	Wiring diagram.....	5g	7
Engine stops suddenly.....	42	25			

**TAGO 6358-A**

By Order of the Secretary of the Army:

**HAROLD K. JOHNSON,**  
*General, United States Army,*  
*Chief of Staff.*

Official:

**J. C. LAMBERT,**  
*Major General, United States Army,*  
*The Adjutant General.*

Distribution:

Active Army:

USASA (2)	USASMC (1)	USA Engr R&D Lab (3)
ACSI (1)	USACDCEC (10)	USAMEC (46)
DCSLOG (2)	MDW (1)	Engr Cen (5)
CNGB (1)	Armies (2)	USAREUR Engr Proc Cen (2)
TSG (1)	Corps (2)	USAREUR Engr Sup Con Agcy (10)
CofEngrs (3)	USAC (1)	Engr FLDMS (2)
CC-E (1)	Div (2)	Ft Knox Fld Maint (10)
Dir of Trans (1)	Engr Bde (1)	Fld Comd, DASA (8)
CofSptS (1)	Svc Colleges(2)	except. AMS (3)
USAMB (1)	Br Svc Sch (2)	USACOMZEUR (2)
USA Arty Bd (2)	USAES (10)	MAAG (1)
USA Armor Bd (2)	USMA (2)	JBUSMC (1)
USAIB (2)	Gen Dep (10)	Units org under fol TOE's:
USAARADBD (2)	Engr Dep (10)	except 5-48 (2)
USAAESWBD (2)	Army Dep (2)	5-237 (5)
USAAVNTBD (2)	TOAD (3)	5-262 (5)
USCONARC (3)	USA Tml Comd (2)	5-267 (1)
OS Maj Comd (5)except	Army Tml (1)	5-278 (5)
USARJ (1)	Div Engr (2)	5-279 (2)
USASETAF (2)	Engr Dist (2)	
USAMOCOM (2)		

NG: State AG (3).

(USAR: Same as active Army except allowance is one copy for each unit.

For explanation of abbreviations used, see AR 320-50.

**TAGO 6358-A**

RECOMMENDED CHANGES TO EQUIPMENT TECHNICAL PUBLICATIONS

 <div style="border: 1px solid black; border-radius: 15px; padding: 5px; display: inline-block; margin-left: 20px;"> <p style="margin: 0;"><i>THEN...JOT DOWN THE DOPE ABOUT IT ON THIS FORM. CAREFULLY TEAR IT OUT, FOLD IT AND DROP IT IN THE MAIL.</i></p> </div>		SOMETHING WRONG WITH PUBLICATION	
		FROM: (PRINT YOUR UNIT'S COMPLETE ADDRESS)	
PUBLICATION NUMBER		DATE SENT	
PUBLICATION DATE		PUBLICATION TITLE	
BE EXACT PIN-POINT WHERE IT IS			
PAGE NO.	PARA- GRAPH	FIGURE NO.	TABLE NO.
<div style="border: 1px solid black; height: 400px; margin-top: 10px;"> <p style="text-align: center; font-weight: bold; margin-top: 10px;">IN THIS SPACE, TELL WHAT IS WRONG AND WHAT SHOULD BE DONE ABOUT IT.</p> </div>			
PRINTED NAME, GRADE OR TITLE AND TELEPHONE NUMBER			SIGN HERE

**PIN: 008461-000**